

Wireless Power Transmission Using Magnetic Resonance

Mandip Jung Sibakoti and Joey Hambleton
Cornell College PHY312, December 2011, Professor Derin Sherman

1. INTRODUCTION

Our project was based upon a MIT published paper in the year 2007 titled “Wireless Power Transfer via Strongly Coupled Magnetic Resonances” [1]. The project was researched by former Cornell students Lucas Jorgensen and Adam Culberson in the year 2008 [2].

During the course of this research, we investigated the need and usefulness of wireless power transmission and the feasibility of using magnetic inductive coupling as the means for wireless power transmission. The paper will outline our design process and the logical steps we took in the experimentation and design of our circuits. The first section of the document will explicitly illustrate the goals we set to accomplish during the allotted time frame of three and a half weeks. With the complexity of the problem in mind and what we must accomplish, our team began research on the available means to transmit power without a physical connection.

1.1 HISTORY

Previous schemes for wireless power transmission included attempts by the late scientist Nikola Tesla and the Microwave power transmission. Both Tesla's design and the later microwave power were forms of radiative power transfer. Radiative transfer, used in wireless communication, is not particularly suitable for power transmission due to its low efficiency and radiative loss due to its omnidirectional nature. An alternative approach was pursued by a MIT team that exploited some near field interaction between the source and device so that efficient power transfer was possible. The approach was evanescent wave coupling.

1.2 THEORITICAL BACKGROUND

The principle of Evanescent Wave Coupling extends the principle of Electromagnetic induction. Electromagnetic induction works on the principle of a primary coil generating a predominantly magnetic field and a secondary coil being within that field so a current is induced within its coils. This causes the relatively short range due to the amount of power required to produce an electromagnetic field. Over greater distances the non-resonant induction method is inefficient and wastes much of the transmitted energy just to increase range. This is where the resonance comes in and helps the efficiency dramatically by "tunneling" the magnetic field to a receiver coil that resonates at the same frequency.

Theoretical analysis shows that by sending electromagnetic waves around in a highly angular waveguide¹, evanescent waves are produced which carry no energy. If a proper resonant waveguide is brought near the transmitter, the evanescent waves can allow the energy to tunnel to the power drawing waveguide, where they can be rectified into DC power. Since the electromagnetic waves would tunnel, they would not propagate through the air to be absorbed or be dissipated, and would not disrupt electronic devices or cause physical injury.

1.3 INTENDED GOALS

Our primary goal was to be able to wirelessly transfer power (in watts) of an AC oscillating waveform into a DC voltage on the receiving end, which could be used to power an electrical load (in watts) to demonstrate instantaneous power transfer. To do this, we intended to design a tunable oscillator capable of generating frequency in the RF band (1MHZ – 20 MHz) and a power amplifier to supply enough power to be transmitted for powering the electrical load. In addition to this, we also intended to demonstrate the evanescent waves by the illustration of an exponential relationship of power transmitted to the receiver as a function of distance of separation between the receiver and transmitter coils.

2. SYSTEM DESIGN

With all the necessary background research completed it became clear what basic design components the entire system would require. First we needed a method to design an oscillator, which would provide the carrier signal with which to transmit the power. Oscillators are not generally designed to deliver power, thus it was necessary to create a power amplifier to amplify the oscillating signal. The power amplifier would then transfer the output power to the transmission coil. Next, a receiver coil would be constructed to receive the transmitted power. However, the received power would have an alternating current, which is undesirable for powering a DC load. Thus, a rectifier would be needed to rectify the AC voltage to output a clean DC voltage. Finally, an electric load would be added to complete the circuit design

¹ A **waveguide** is a structure which guides waves, such as electromagnetic waves. There are different types of waveguides for each type of wave. The original and most common meaning is a hollow conductive metal pipe used to carry high frequency radio waves. (in our case the copper tube as in the figure).

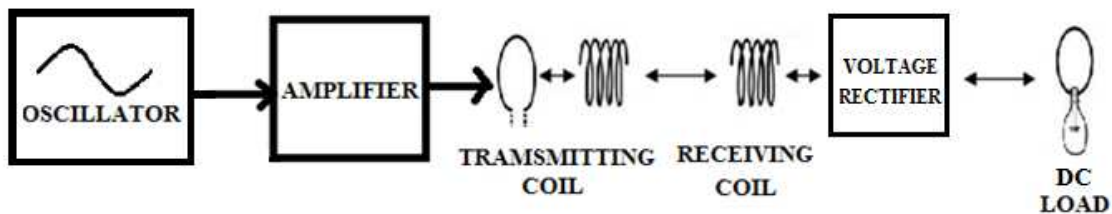
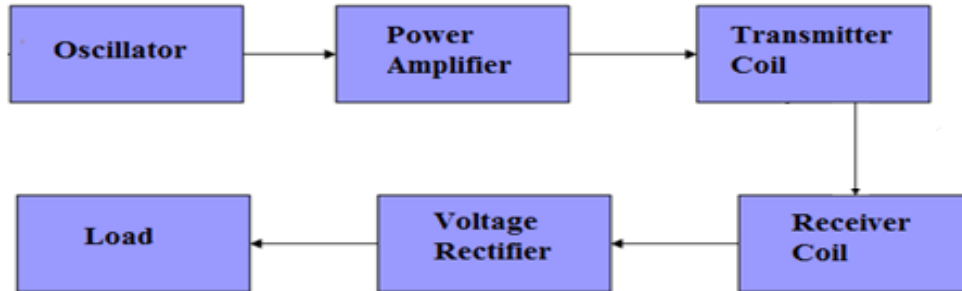

2.1 OSCILLATOR

There are two general classes of oscillators: sinusoidal and relaxation. Op-Amp sinusoidal oscillators operate with some combination of positive and negative feedback to drive the op-amp into an unstable state, causing the output to transition back and forth at a continuous rate. Relaxation Op-Amp oscillators operate with a capacitor, a resistor or a current source to charge/discharge the capacitor, and a threshold device to induce oscillation.

The oscillator design that we utilized was a relaxation oscillator using a single Operational amplifier. This oscillator was a Square Wave Generator and could be classified in the category as an astable multivibrator.

2.1.1 DESIGN

In the design of a Relaxation oscillator, as shown in the figure below, we used a high speed Operational amplifier, AD829, which had a very high frequency response of 120 MHz. The operational amplifier was connected in a Schmitt-trigger² configuration with positive feedback through a resistor of 500 Ohms and a variable resistor of 1K. The inverting input for the Op-Amp was biased with a capacitor of 20pF and a resistor of 200 Ohms.

² For the reference of the configuration, link: http://en.wikipedia.org/wiki/Schmitt_trigger

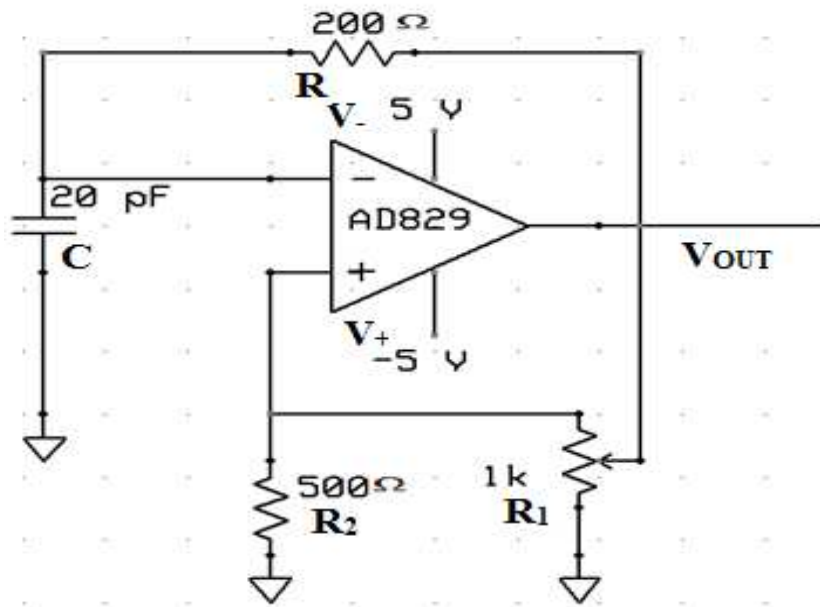

WORKING PRINCIPLE:

Initially, the non-inverting input at the Op-Amp is biased at a voltage of $V_{OUT} * R_2 / (R_2 + R_1)$ and the op-amp's output is saturated at that particular voltage level. Since the op-amp always attempts to keep both its inverting and the non-inverting inputs, V_+ and V_- equal to each other, the feedback causes the 20pF capacitor to charge and make the value of V_- equal to V_+ . When V_- reaches the value of V_+ , a switch to negative saturation at the output occurs and the capacitor begins to discharge. The charging and discharging of the oscillator effectively causes an oscillating signal to the output.

The general equation for charging a capacitor is given by:

$$q = CV (1 - e^{-t/RC}) + q_0 e^{-t/RC}$$

In this case, V is $-V_{OUT}$, and if the voltage at V_+ is called λV_{OUT} , q_0 becomes CV_{OUT} .

The charging equation then becomes

$$q = -CV_{OUT}(1 - e^{-t/RC}) + \lambda CV_{OUT} e^{-t/RC}$$

When q gets to $-\lambda CV_{OUT}$, another switch will occur. This time it is half the period of the square wave. Therefore:

$$-\lambda CV_{OUT} = -CV_{OUT}(1 - e^{-t/RC}) + \lambda CV_{OUT} e^{-t/RC}$$

Solving for T gives:

$$T = 2RC * \ln\left[\frac{1+\lambda}{1-\lambda}\right] \quad \text{where} \quad \lambda = \frac{R_2}{R_2+R_1}$$

The frequency of oscillation can be determined by $\frac{1}{T}$. In our case, the variable resistor R_1 could be varied using a 1K pot which was able to tune the frequency from 1.6 MHz to 10.3 MHz.

2.1.2 RESULTS

The figure below shows the signal output from the signal generator at frequencies tuned by varying the resistance using the 1K pot. The signal was very stable and free of any extraneous noise that may have caused distortion or ringing in the signal.

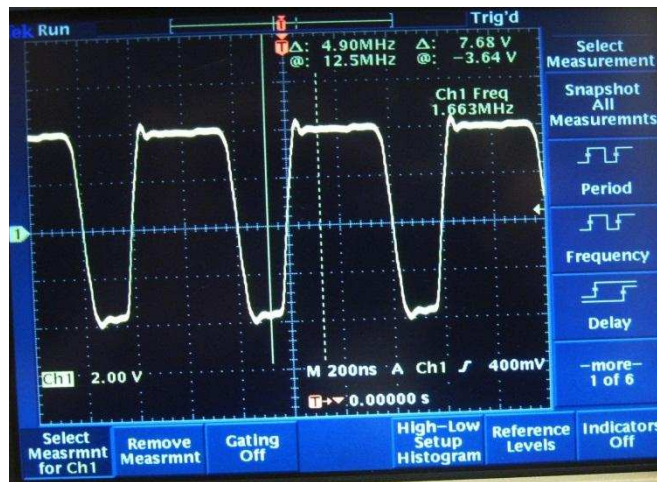

At frequency range from 1.6 MHz – 3.85 MHz, the signal was a square wave.

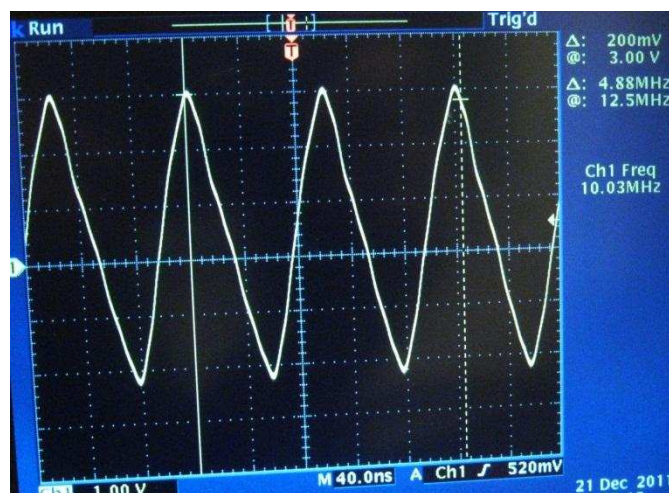

At frequencies range from 3.85 MHz – 10.3 MHz, the signal looked like a triangle wave.

2.1.2 DESIGN DETAILS

The challenges encountered during the design of the oscillator were the selection of the oscillator design and the Op-Amp chip required to produce a stable and symmetrical oscillating signal. We had experimented with IC Logic chips and low frequency response Op-Amp chips for the design of the oscillator. However, the oscillation signal output from these circuit configurations was not stable or symmetrical. We also initially had problems with distortion of the signal by the unstable power supply from the PCB board and other extraneous noise at high frequencies. We dealt with this problem by neatly laying out the relaxation oscillator circuit using shorter wires and the placing two decoupling capacitors of one microfarads each between the positive and negative power supply to the ground.

2.2 POWER AMPLIFIER

In order to generate the maximum amount of flux which would induce the largest voltage on the receiving coil, a large amount of current must be transferred into the transmitting coil. The oscillator was not capable of supplying the necessary current, thus the output signal from the oscillator was passed through a power amplifier to produce the necessary current. The key design aspect of the power amplifier was to generate enough current while producing a clean output signal without large harmonic distortions. For this purpose, we utilized a simple switch-mode amplifier design whose design aspects are described below.

2.1.1 DESIGN

The main idea behind the switch-mode Power Amplifier technology is to operate a MOSFET in saturation so that either voltage or current is switched on and off. The figure below shows the circuit diagram of the switch-mode power amplifier.

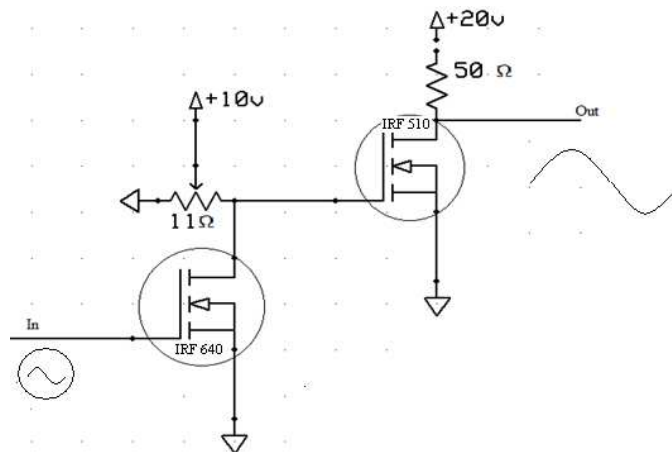

Our switch-mode design consisted of a MOSFET IRF 510, which when turned on allowed large current from the DC power supply to flow through the resistor of 50 Ohms and through the transmitting antenna to transfer current from the power supply through the transmitting coil. The large current from the transmitting coil was able to

generate a large flux to induce a high voltage in the receiving coil. The current and voltage required to drive the gate of the MOSFET IRF 510 was supplied by the MOSFET IRF 640 whose gate was driven by the input signal from a Hewlett Packard signal generator. The maximum voltage when the coils were tuned at resonance was recorded to be around 102.3V.

2.1.2 DESIGN DETAILS

Since our single op-amp relaxation oscillator was using an AD 829 chip, it was not able to source enough current to drive the Mosfet IRF 510 or control the amplitude of the output signal. For this reason, we employed the Hewlett Packard 3310A Function Generator as our oscillator. The signal generator was capable of supplying current and voltage required for driving the gate of the IRF640. Furthermore, using the signal generator, we were also able to set the DC bias voltage and tune the output voltage to get maximum voltage out.

The major challenge while designing the power amplifier circuit was to drive the gate of the Mosfet IRF 510 to switch the Mosfet on. Our initial approach was to design a class D amplifier to drive a H-Bridge³ configuration (which meant driving 4 IRF 510 Mosfet) for an efficient power amplification using a single positive power supply. The H-Bridge⁴ required two digital signals that were 180 degrees out of phase with a small dead-time in between the signals. The whole second week we were working on trying to generate these signals as inputs to the H-bridge. In generating these signals, we encountered problems with our comparator chips to output noise free digital signals at high frequency (5 MHz range). Using 2 high speed comparators, LT1016, and introducing terminating resistances (68 Ohm) in series to the output, we were able to output digital signals 180 out of phase with a small dead time for the input to the H-Bridge.

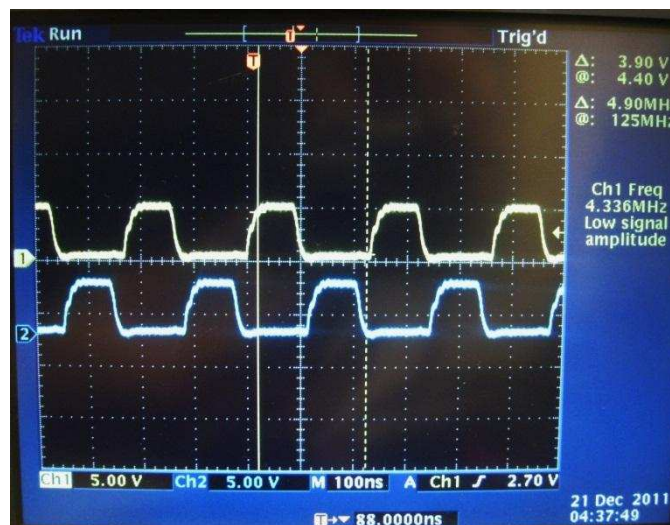

³ For the reference of the configuration, link: <http://mcmmanis.com/chuck/robotics/tutorial/h-bridge/>

However, the signal output from the comparators as can be seen from the image above was unable to turn the Mosfet IRF 510 on. The comparator could not source enough current to drive the gate of the Mosfet to turn on at a frequency range of around 5 MHz.

2.3. TRANSMITTER AND RECEIVER COILS

The transmitter and receiver circuit combined is called the coupling circuit. It is the heart of the entire system as the actual wireless power transfer is carried out here. The efficiency of the coupling circuit determines the amount of power available for the receiver system.

2.1.1. DESIGN

The transmitter and receiver coils were designed by former Cornell students, Lucas Jorgensen and Adam Culberson. The coils had a resonant frequency of 4.8 – 5.3 MHz, which could be tuned with our oscillator (later a signal generator) to get to the resonance frequency of the coils. The basic configuration of the design can be seen from the table and the image below.

Transmitting Coil	No of turns	10
	Diameter of each turn	60.32 cm
	Diameter of copper tube	0.95 cm
Receiving Coil	No of turns	10
	Diameter of each turn	60.32 cm
	Diameter of copper tube	0.95 cm
Transmitting Antenna	No of turns	1
	Diameter of each turn	56.1 cm
	Diameter of copper wire	0.23 cm
Receiving Antenna	No of turns	2
	Diameter of each turn	44.6 cm
	Diameter of copper wire	0.23 cm

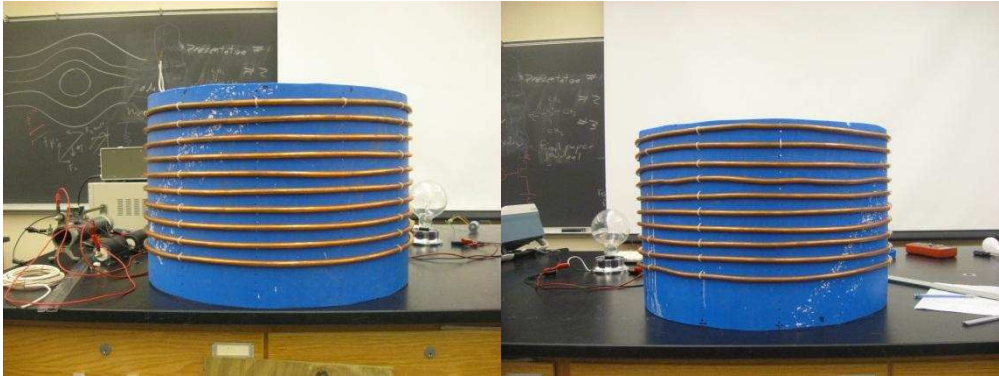

Transmitting Coil (with a loop antenna)

Receiving Coil (with 2 loops of antenna)

2.4 VOLTAGE RECTIFIER:

A rectifier would be needed to rectify the AC voltage received from the receiver coil to drive a DC load. A type of circuit that produces an output waveform that generates an output voltage which is purely DC or has some specified DC component is a Full Wave Bridge Rectifier. This type of single phase rectifier uses four individual rectifying diodes connected in a closed loop "bridge" configuration to produce the desired output. The smoothing capacitor connected to the bridge circuit converts the full-wave rippled output of the rectifier into a smooth DC output voltage.

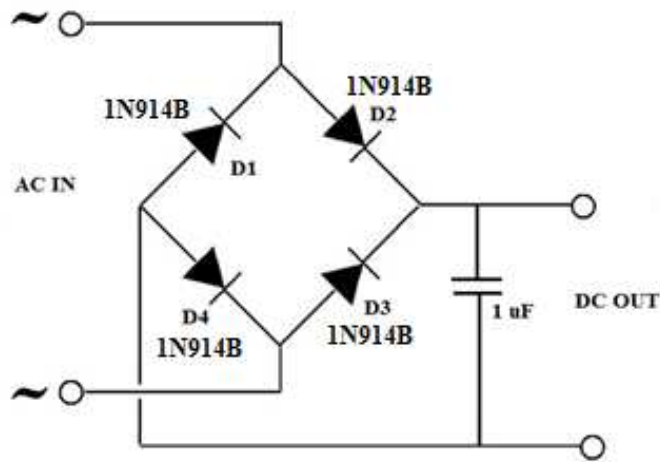

Since the diodes had to rectify AC signals of Megahertz frequencies, fast signal diodes, 1N914B, had to be used for the bridge circuit. However we did not implement this circuit with our final setup as we did not drive a DC load with our setup.

3. RESULTS AND MEASUREMENTS:

At a distance of 0.18 cm between the two coils, we were able to transmit enough power to power a 40 W light bulb. As the distance of separation between the coils was increased, the bulb got dimmer. It was evident from this simple experiment itself that the power transmitted was related to the distance of separation between the coils.

To demonstrate the presence of evanescent waves being produced which transferred power from the transmitter coil to the receiver coil, we measured the voltage across the 40 Watt light bulb at varying distances and orientations. We took measurements starting at a distance of 0.5 m between the coils in 10 cm increments up to a distance of 2 m of separation. We found that the resonant frequency changed with distance due to the imperfect match in the resonant frequencies of our coils. The frequency was then adjusted to find the maximum output voltage at every measurement.

PARALLEL CONFIGURATION:

The coils were arranged in the configuration as shown below and voltage measurements were taken as a function of distance between the coils.

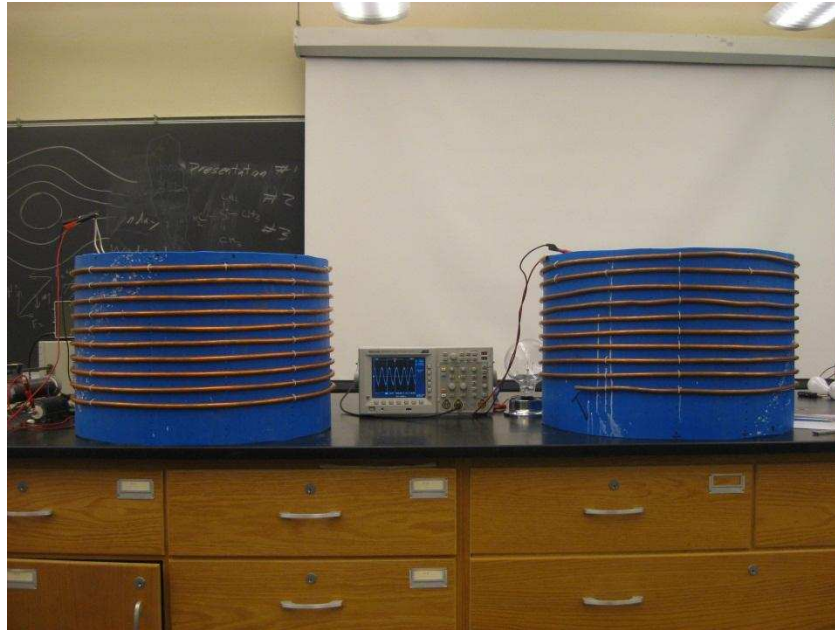

Based upon the data we collected, the following graph shows voltage as a function of distance between the coils.

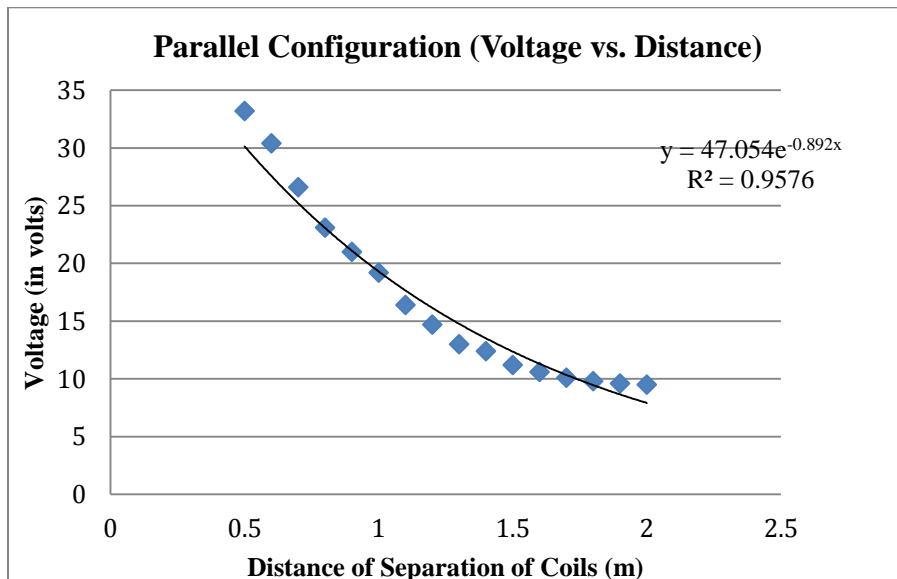

Since the coefficient of determination (R^2) has a value close to 1 for the exponential fit, the data points were strongly exponentially correlated. In other words, the voltage decayed exponentially as the distance of separation between the coils was increased. This

illustrates the theory of power transmitted through evanescent waves that decay exponentially as the distance between the coils was increased.

Similar observation of exponential fit was observed when the coils were faced perpendicular to each other as shown below.

PERPENDICULAR CONFIGURATION:

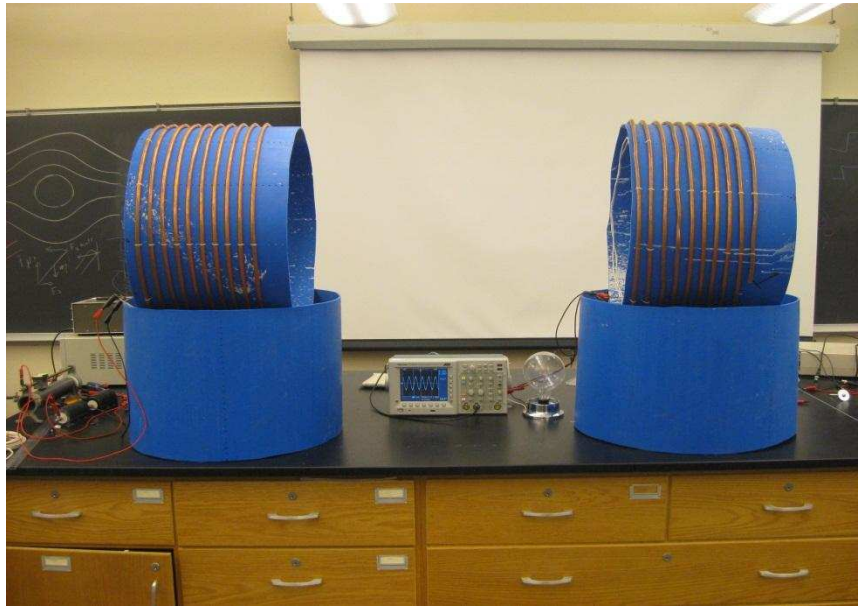

Based upon the data we collected, the following graph shows voltage as a function of distance between the coils.

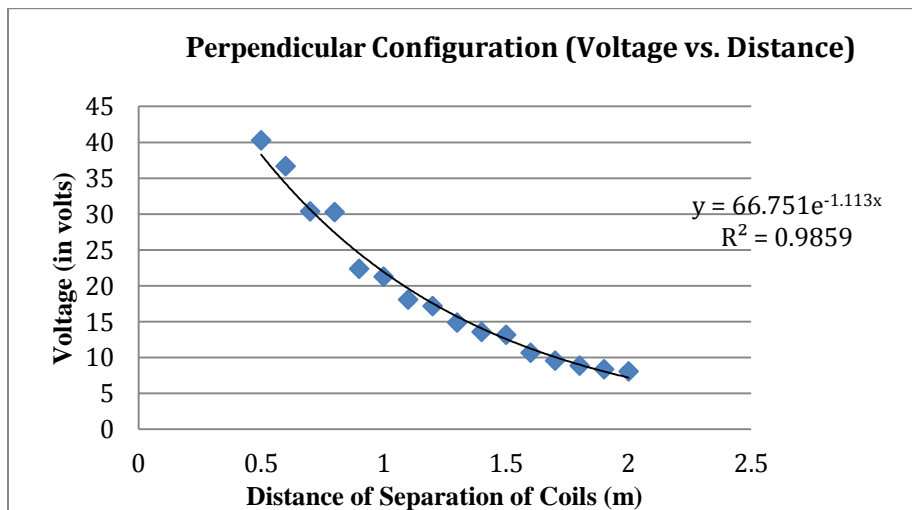

In this case, the value of the coefficient of determination (R^2) is closer to 1 than when the coils were placed parallel to each other. The strong exponential correlation in this case

also illustrates the exponential decay of evanescent waves propagating from the transmitting coil to the receiving coil.

4. CONCLUSION AND FUTURE WORK:

At the end of the research, we were able to design a system for transmitting watts of power wirelessly from the transmitting coil to the receiving coil that was enough to light a 40W bulb. We were able to design discrete components such as the relaxation oscillator, switch mode-power amplifier and a full bridge voltage rectifier for the system design process. We also managed to demonstrate evanescent waves by measuring exponential decay of voltage as an increase in distance between the transmitter and the receiver coils.

There can be significant research work that can be done in the future of this research. Future work includes connecting the relaxation oscillator with the power amplifier using current amplifier chip for providing enough current to drive the gate of the Mosfet to drive the efficient class D H-Bridge power amplifier. Also, reduction in the size of the transmitting and receiving coils and utilizing the regulated signal to power a DC load could be something that could be worked in the future as a means to make this system feasible for practical applications.

5 REFERENCES:

5.1 ORIGINAL MIT PAPER:

[1] Andre Kurs, Aristeidis Karalis, Robert Moffatt, J. D. Joannopoulos, Peter Fisher, Marin Soljacic. 2008. Wireless Power Transfer via Strongly Coupled Magnetic Resonances. Science. <http://www.sciencemag.org/cgi/rapidpdf/1143254?ijkey=94ff.Ay4jRMqU&keytype=ref&siteid=sci> (accessed December 5, 2011).

5.2 LINK TO THE PROJECT BY ADAM AND LUCAS:

[2] <http://www.cornellcollege.edu/physics/courses/phy312/Student-Projects/Magnetic-Resonance/Magnetic-Resonance.html>

5.3 THEORY AND COMPONENTS DESIGN:

[3] G. L. Peterson, "THE WIRELESS TRANSMISSION OF ELECTRICAL ENERGY," [online document], 2004, [cited 12/10/04], <http://www.tfcbooks.com/articles/tws8c.htm>

[4] U.S. Department of Energy, "Energy Savers: Solar Power Satellites," [online document] rev 2004 June 17, [cited 12/10/04], <http://www.eere.energy.gov/consumerinfo/factsheets/1123.html>

[5] S. Kopparthi, Pratul K. Ajmera, "Power delivery for remotely located Microsystems," Proc. of IEEE Region 5, 2004 Annual Tech. Conference, 2004 April 2, pp. 31-39.

- [6] Tomohiro Yamada, Hirotaka Sugawara, Kenichi Okada, Kazuya Masu, Akio Oki and Yasuhiro Horiike, "Battery-less Wireless Communication System through Human Body for in-vivo Healthcare Chip," IEEE Topical Meeting on Silicon Monolithic Integrated Circuits in RF Systems, pp. 322-325, Sept. 2004.
- [7] "Category: Radio spectrum -Wikipedia, the free encyclopedia," [online document], 2004 Aug 26 [cited 12/11/04], http://en.wikipedia.org/wiki/Category:Radio_spectrum.
- [8] Zia A. Yamayee and Juan L. Bala, Jr., Electromechanical Energy Devices and Power Systems, John Wiley and Sons, 1947, p. 78.
- [9] "The Spark Transmitter. 2. Maximizing Power, part 1. " November 2004, <http://home.freeuk.net/dunckx/wireless/maxpower1/maxpower1.html>.
- [10] R. Victor Jones, "Diode Applications," [Online Document], 2001 Oct 25, [cited 2004 Dec 11], http://people.deas.harvard.edu/~jones/es154/lectures/lecture_2/diode_circuits/diode_appl.html.
- [11] Central Semiconductor Corp, "PNP Silicon Transistor", November 2004, http://www.semiconductors.philips.com/acrobat_download/datasheets/2N2222_CNV_2.pdf.
- [12] Neha Bagga, Joshua Gruntmeir, Samuel Lewis, "Wireless Power Transmission", Dec.2004.
- [13] Online source, http://diranieh.com/Electrenicas/OpAmps3.htm#Relaxation_Oscillator.
- [14] Online source, <http://www.scribd.com/doc/51651503/81/Relaxation-Oscillators-Using-Operational-Amplifier>.

5.4 DATASHEET FOR CHIPS:

- [15] Referenced using the website, <http://www.alldatasheet.com>