



US 20100224696A1

(19) **United States**
(12) **Patent Application Publication**
Rogers et al.

(10) **Pub. No.: US 2010/0224696 A1**
(43) **Pub. Date: Sep. 9, 2010**

(54) **WEATHER MANAGEMENT USING SPACE-BASED POWER SYSTEM**

(60) Provisional application No. 60/428,928, filed on Nov. 26, 2002.

(75) Inventors: **James E. Rogers**, Hermosa Beach, CA (US); **Gary T. Spirnak**, Manhattan Beach, CA (US)

Publication Classification

(51) **Int. Cl.**
A01G 15/00 (2006.01)
(52) **U.S. Cl.** **239/14.1**

Correspondence Address:
Vista IP Law Group LLP
2040 MAIN STREET, Suite 710
IRVINE, CA 92614 (US)

(57) **ABSTRACT**

Space-based power system and method of altering weather using space-born energy. The space-based power system maintains proper positioning and alignment of system components without using connecting structures. Power system elements are launched into orbit, and the free-floating power system elements are maintained in proper relative alignment, e.g., position, orientation, and shape, using a control system. Energy from the space-based power system is applied to a weather element, such as a hurricane, and alters the weather element to weaken or dissipate the weather element. The weather element can be altered by changing a temperature of a section of a weather element, such as the eye of a hurricane, changing airflows, or changing a path of the weather element.

(73) Assignee: **SOLAREN CORPORATION**, Manhattan Beach, CA (US)

(21) Appl. No.: **12/723,618**

(22) Filed: **Mar. 12, 2010**

Related U.S. Application Data

(60) Division of application No. 11/359,852, filed on Feb. 22, 2006, Continuation of application No. 11/212,824, filed on Aug. 25, 2005, now Pat. No. 7,612,284, Continuation of application No. 10/724,310, filed on Nov. 26, 2003, now Pat. No. 6,936,760.

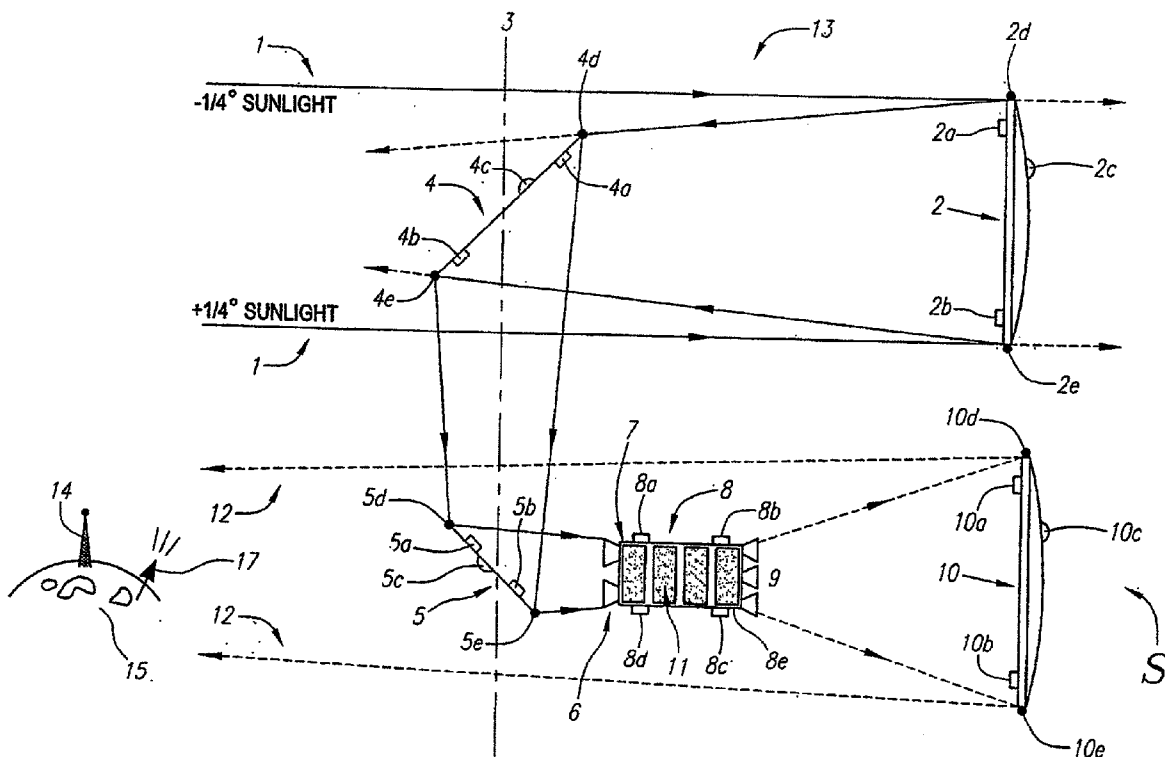

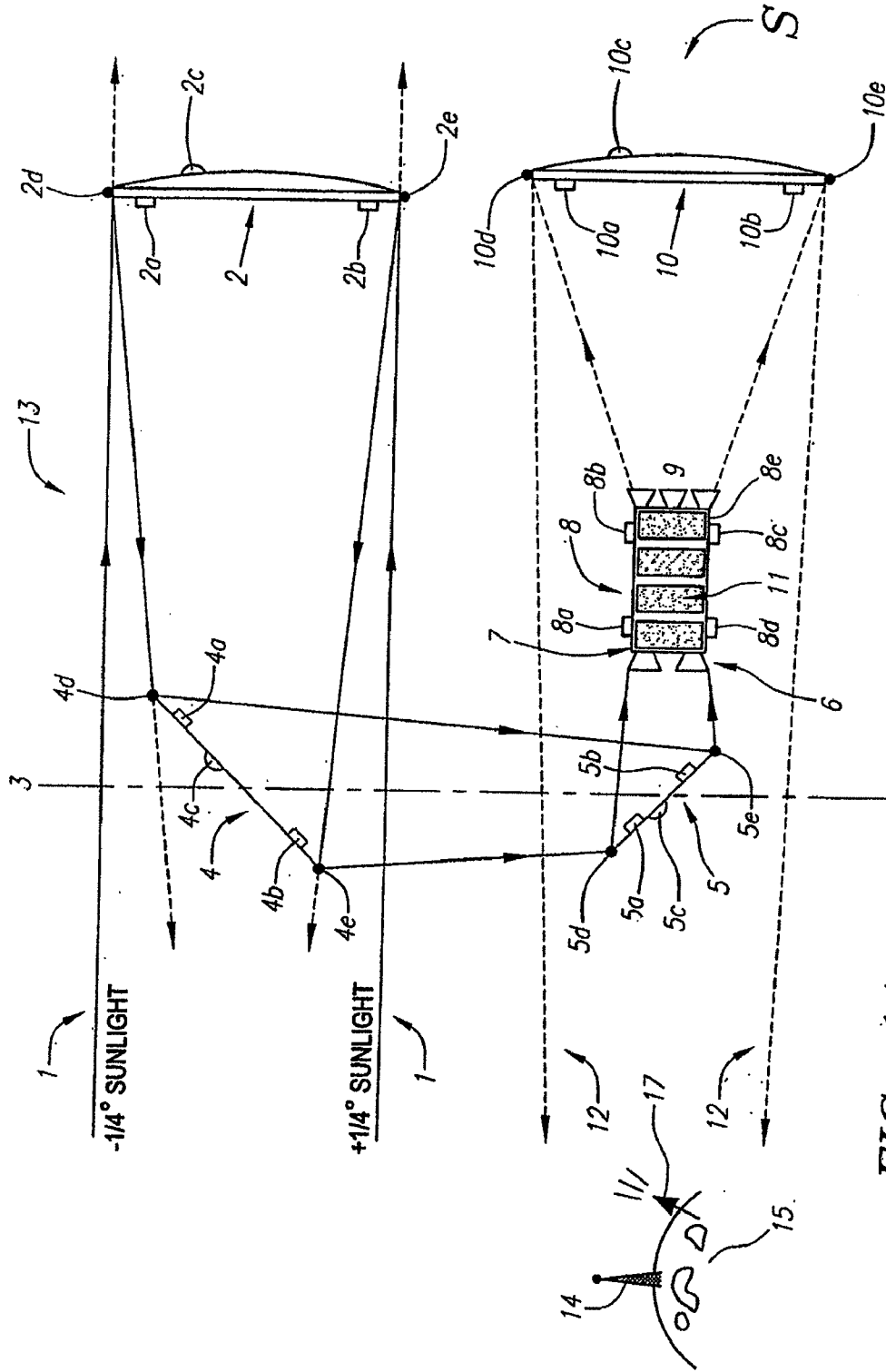

FIG. 1A

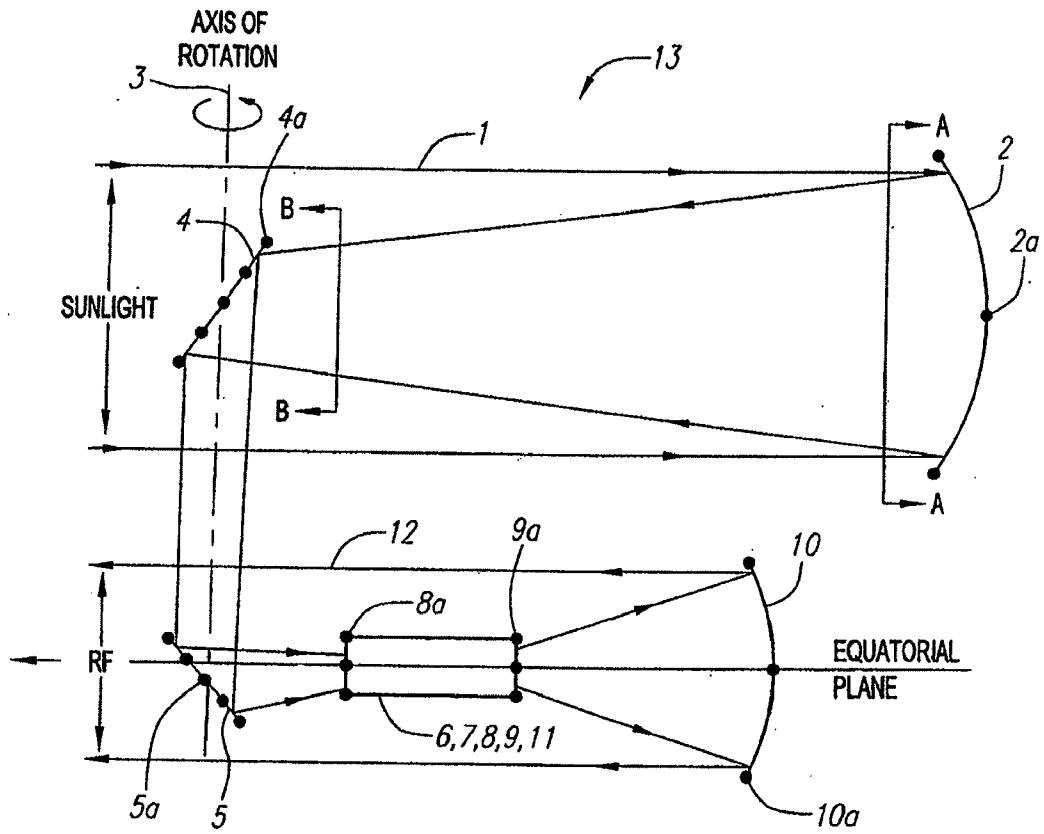

FIG. 1B

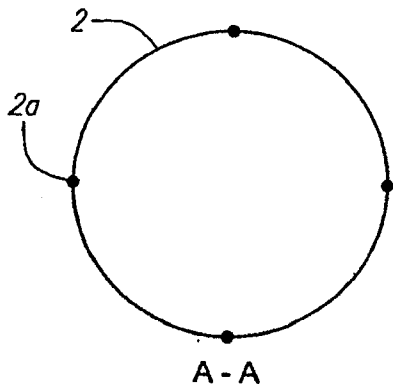

FIG. 1C

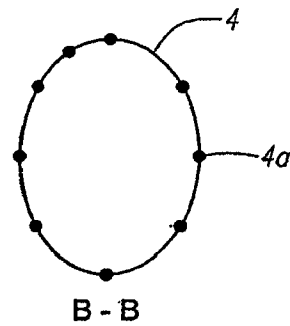

FIG. 1D

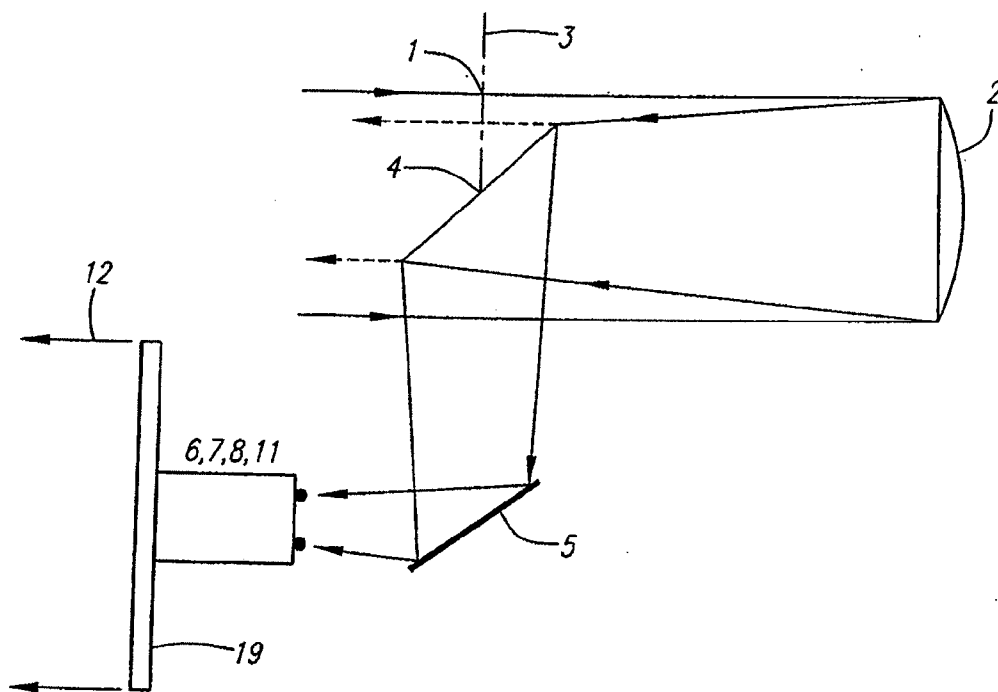

FIG. 1E

FIG. 2A

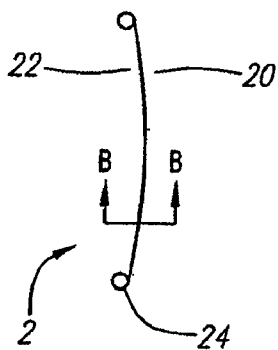
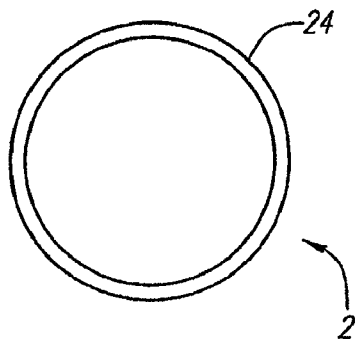

FIG. 2B

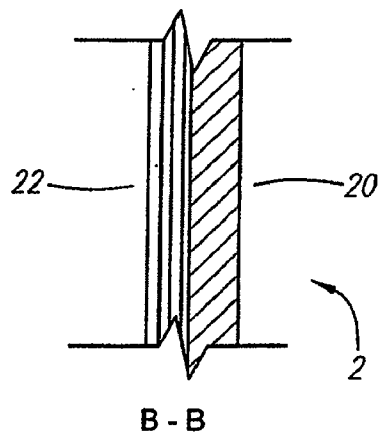

FIG. 3

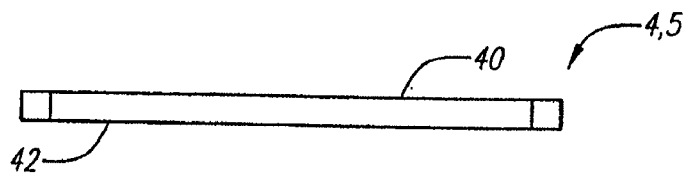

FIG. 4A

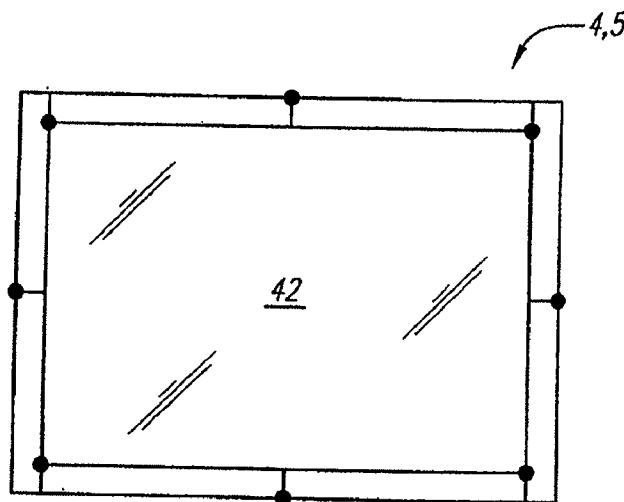

FIG. 4B

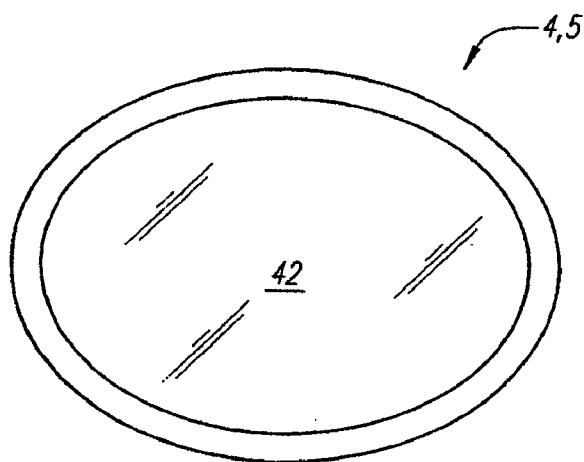

FIG. 4C

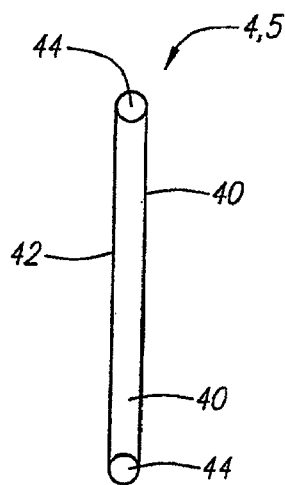

FIG. 4D

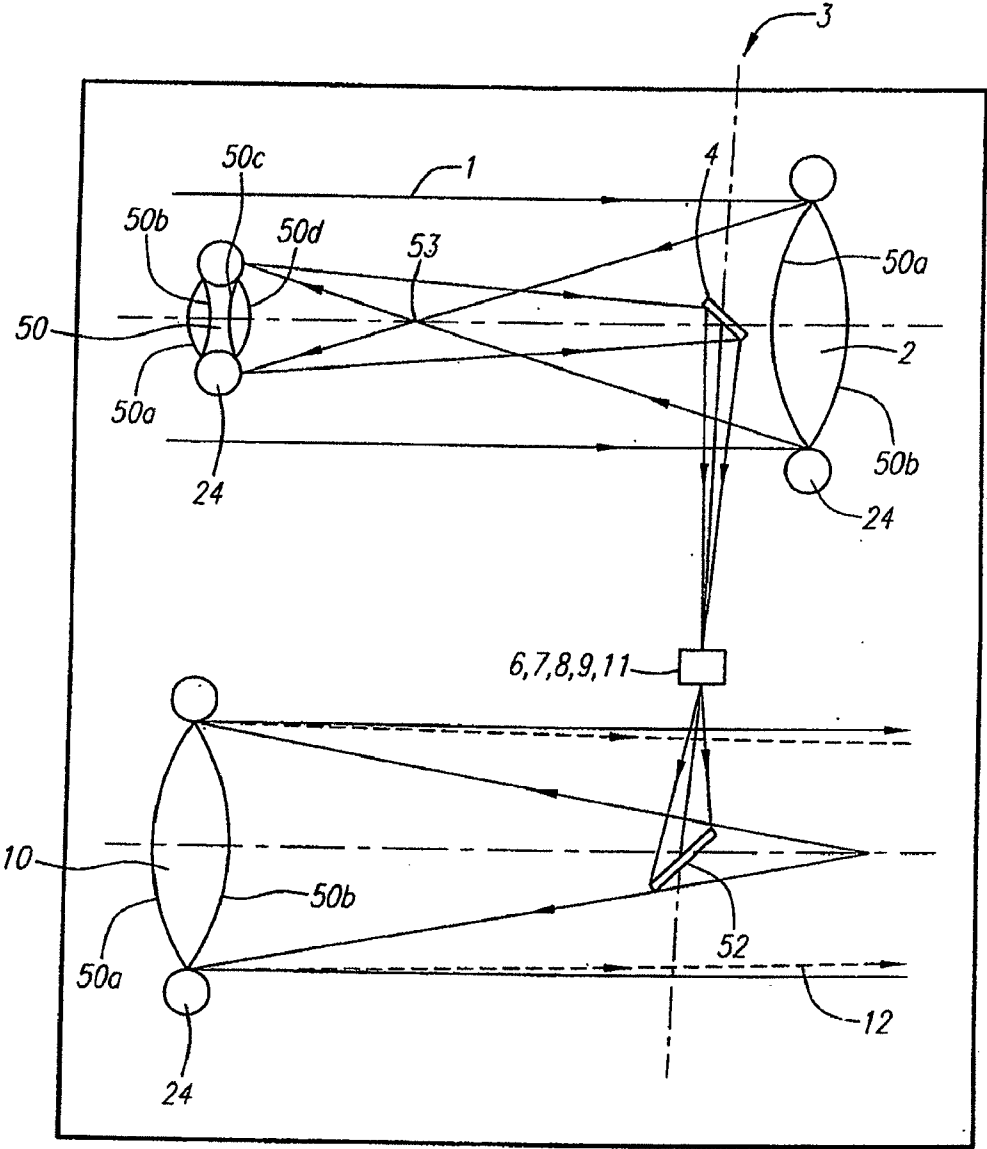

FIG. 5

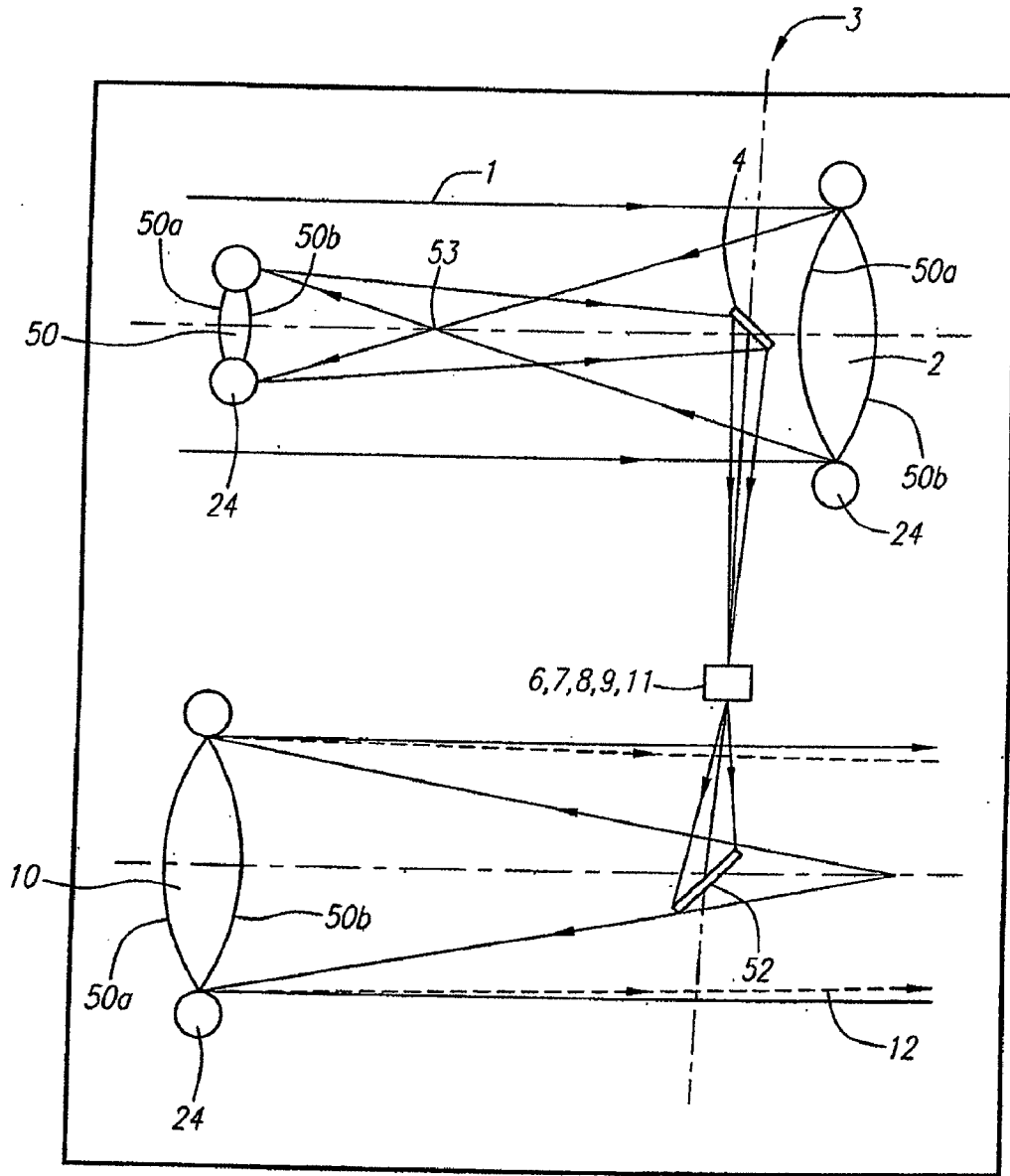

FIG. 6

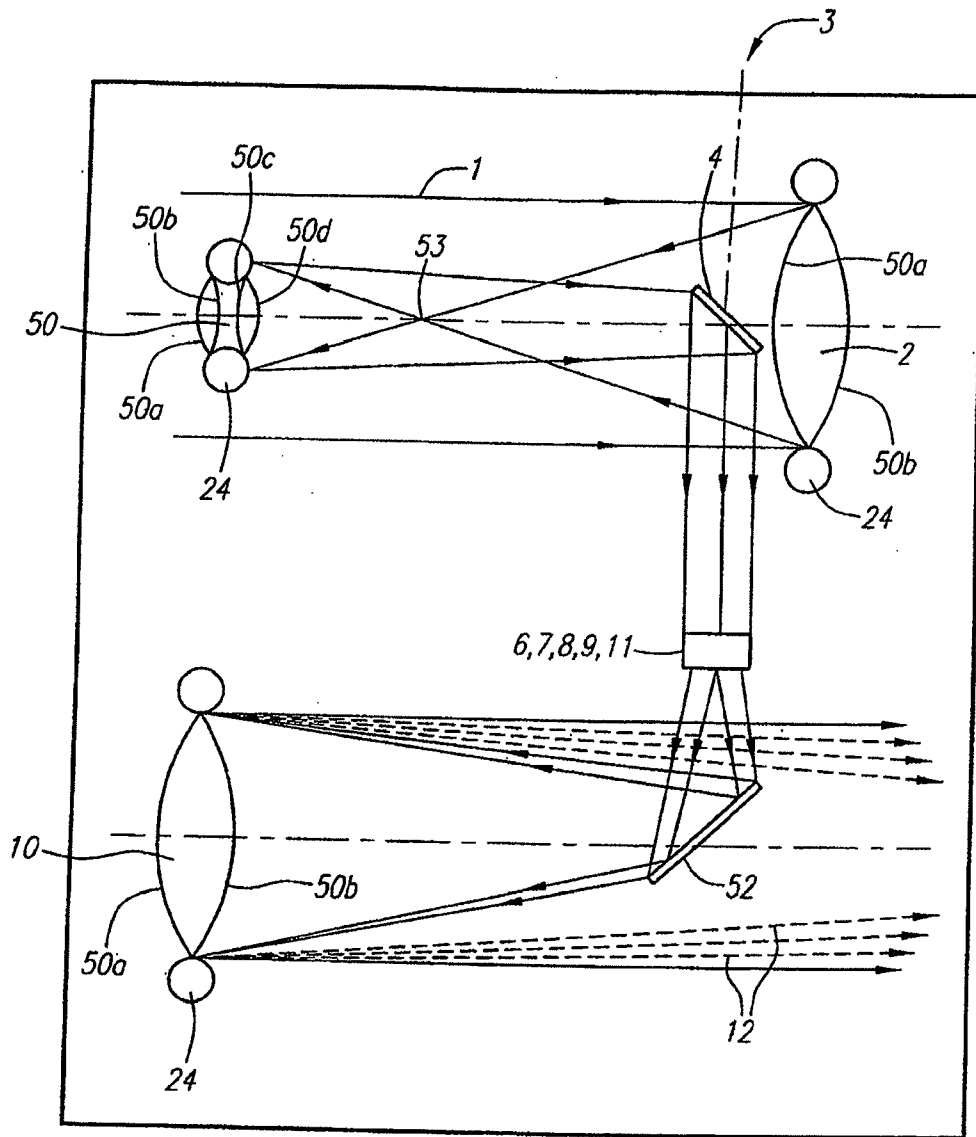

FIG. 7

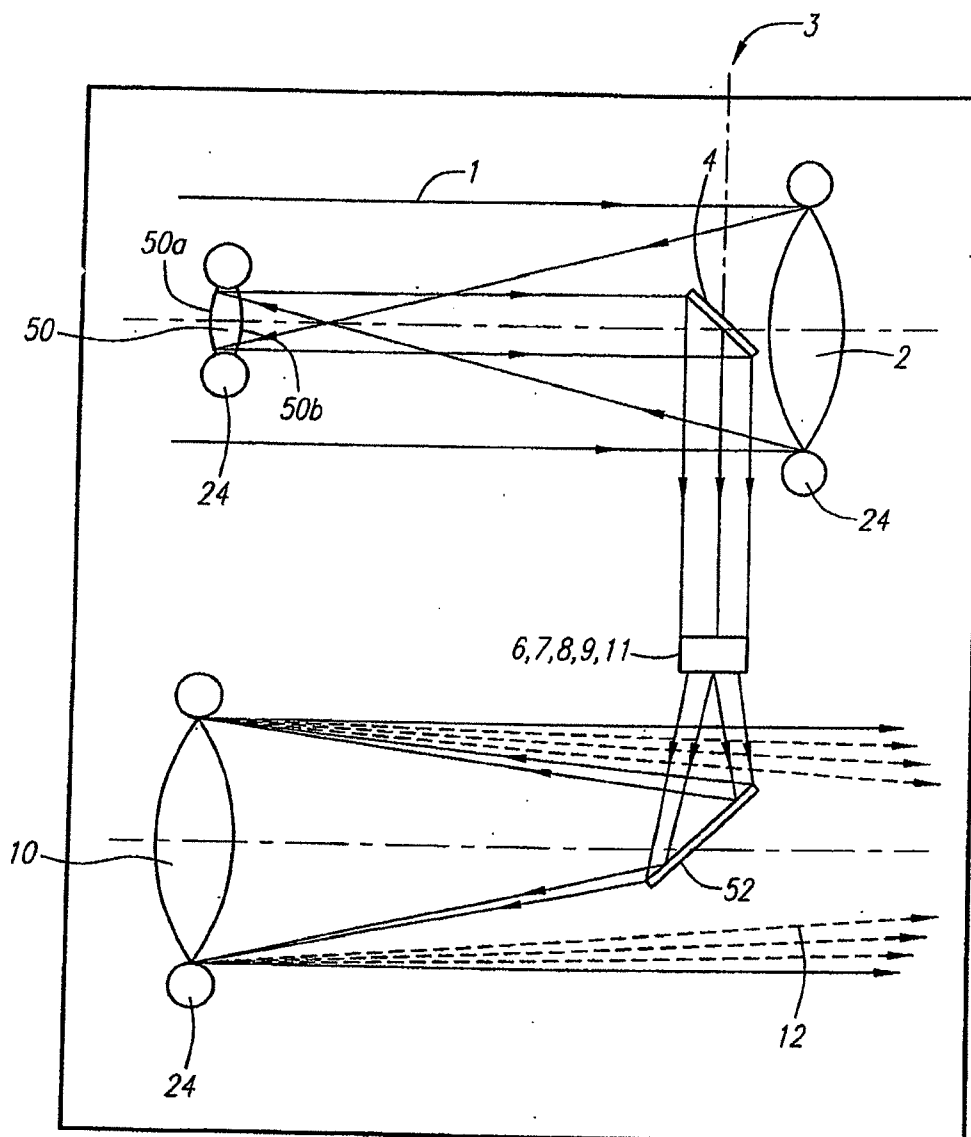

FIG. 8

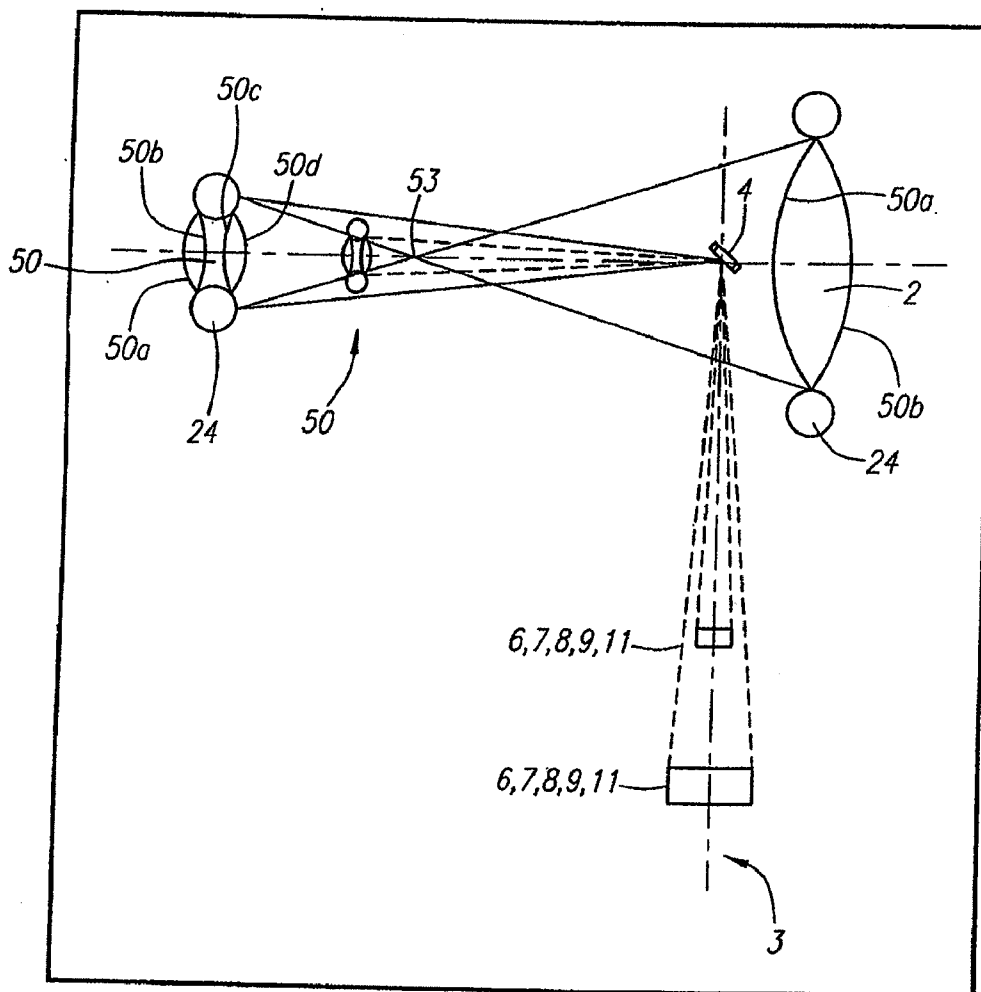

FIG. 9

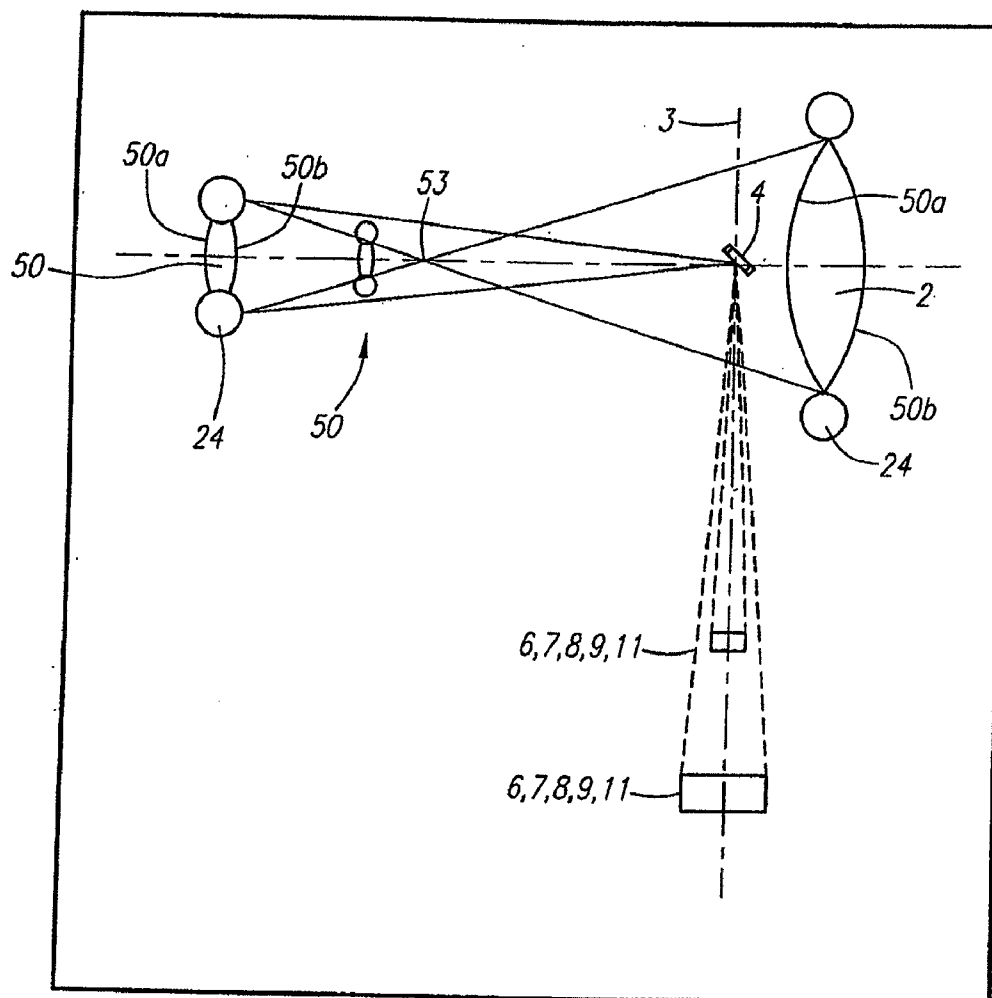

FIG. 10

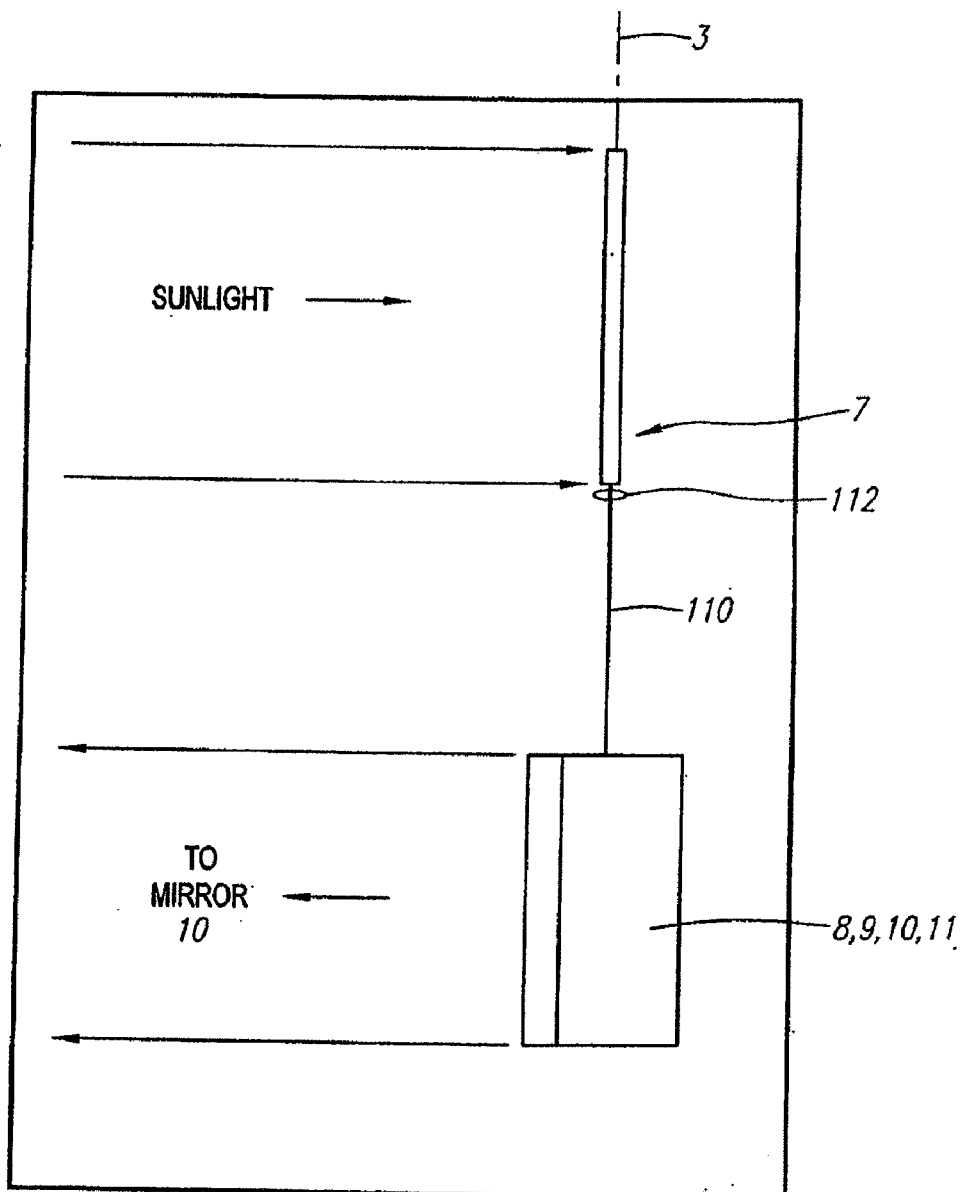

FIG. 11

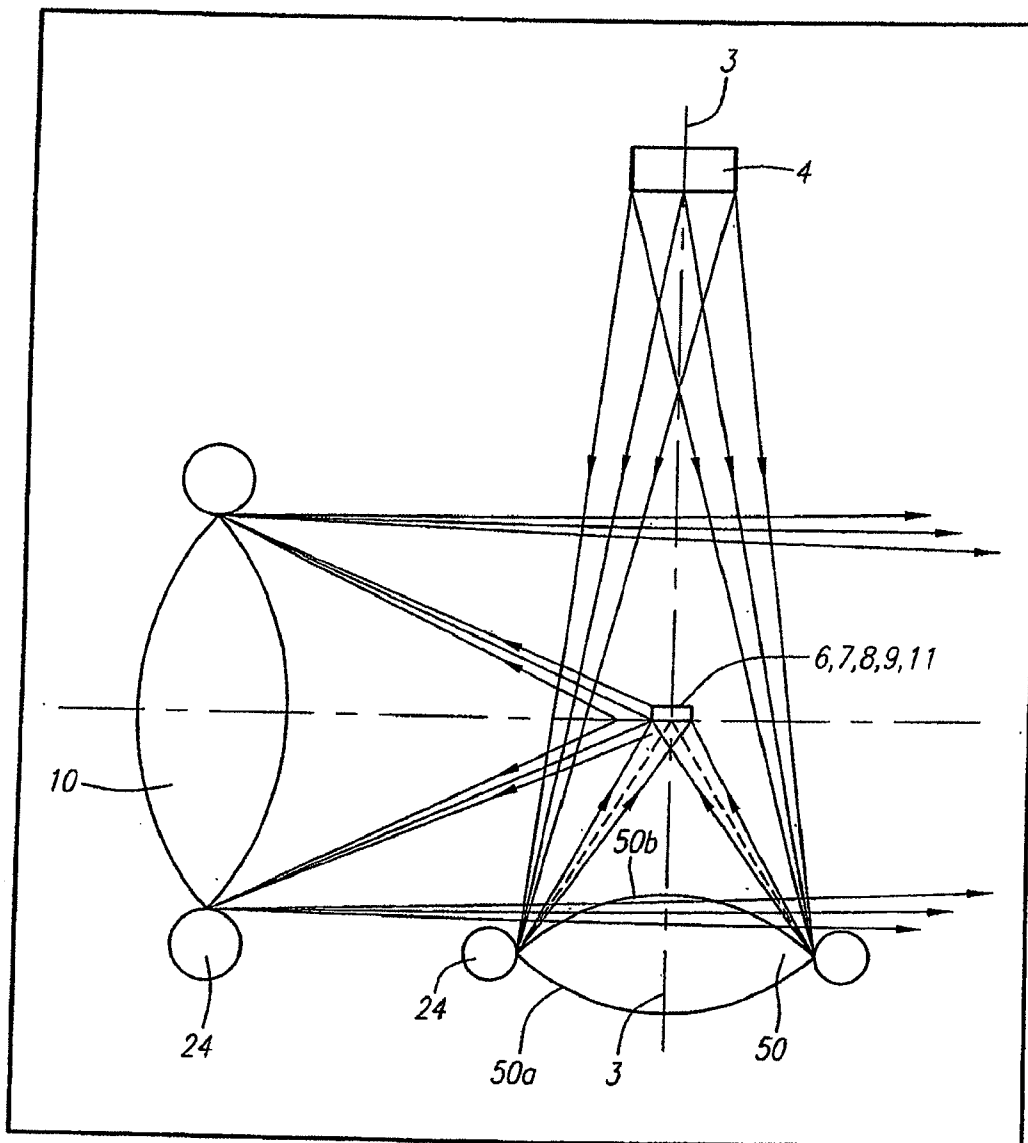

FIG. 12

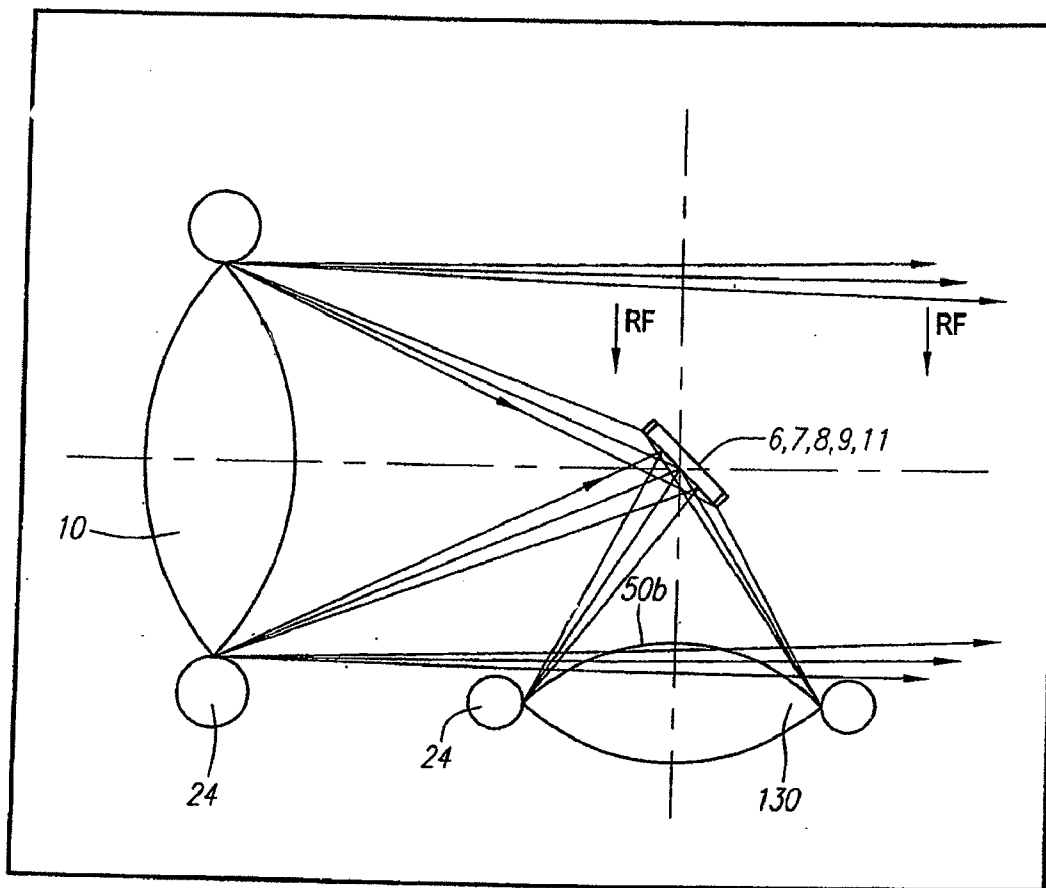

FIG. 13

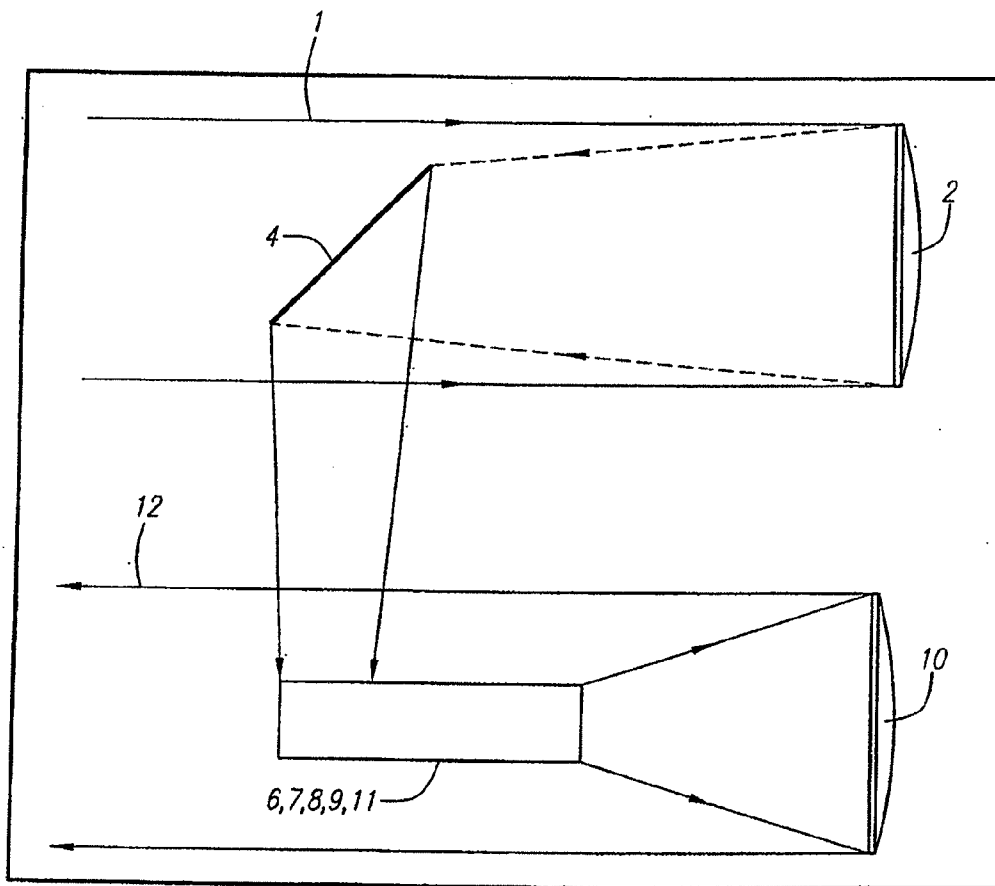

FIG. 14

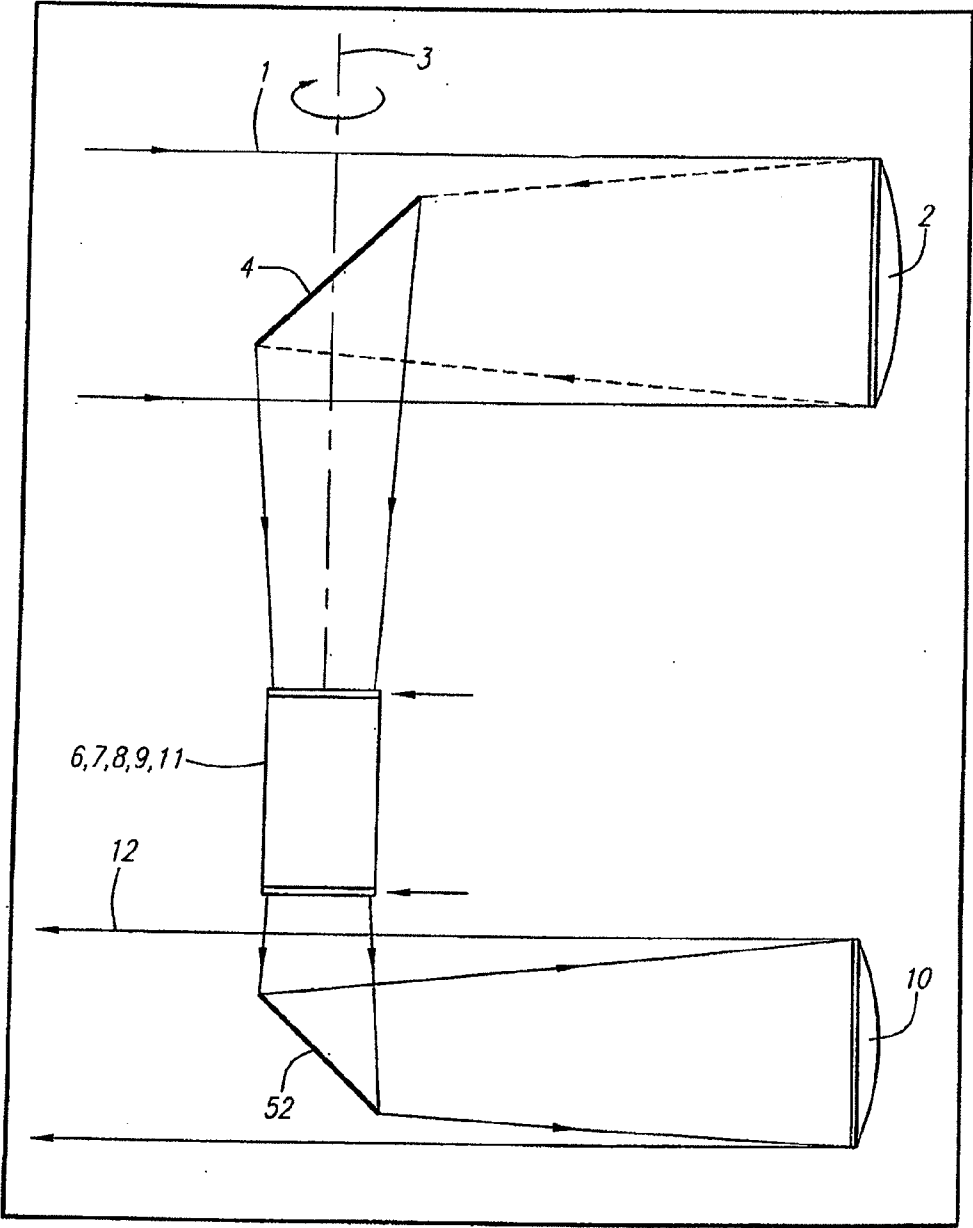

FIG. 15

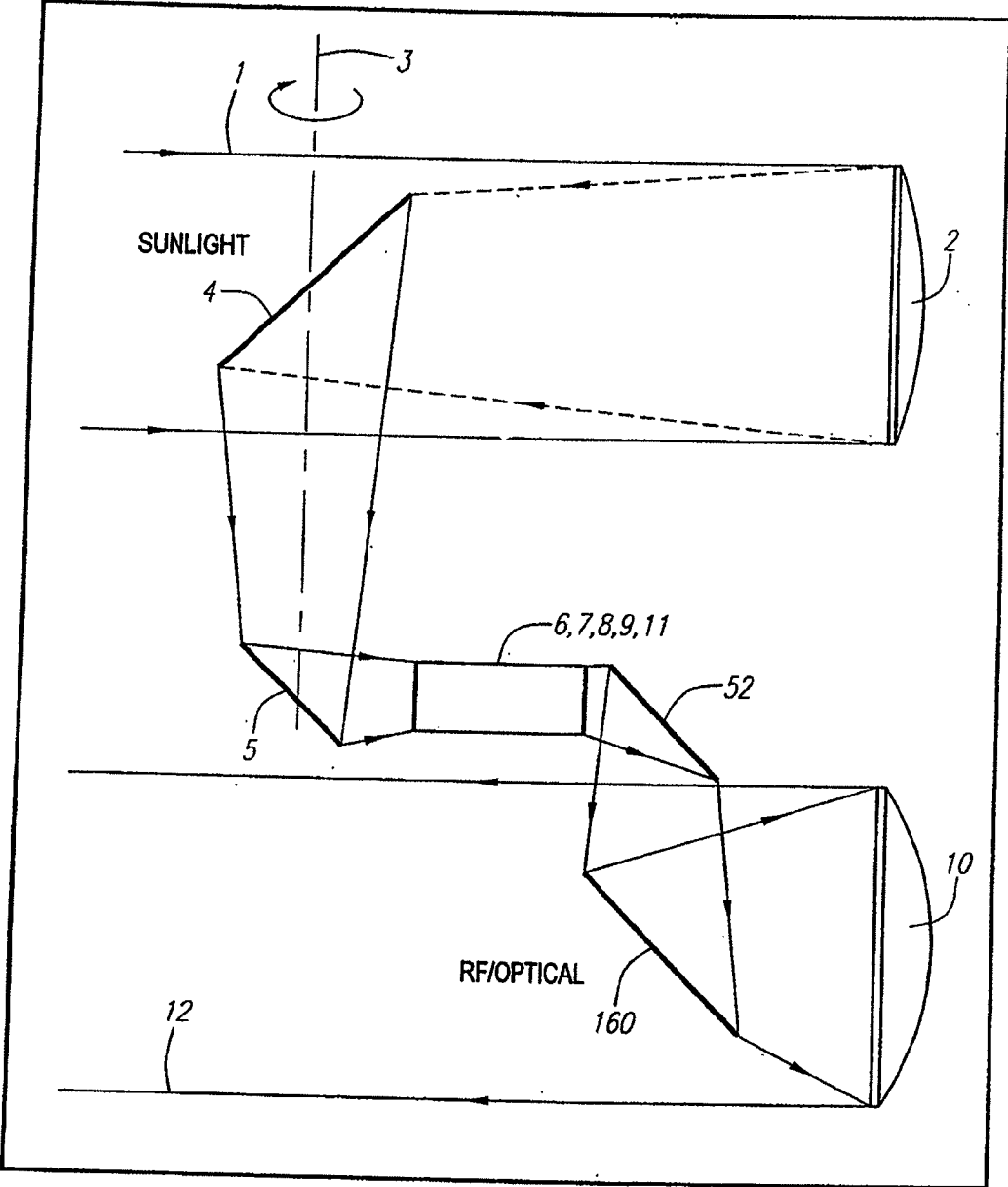

FIG. 16

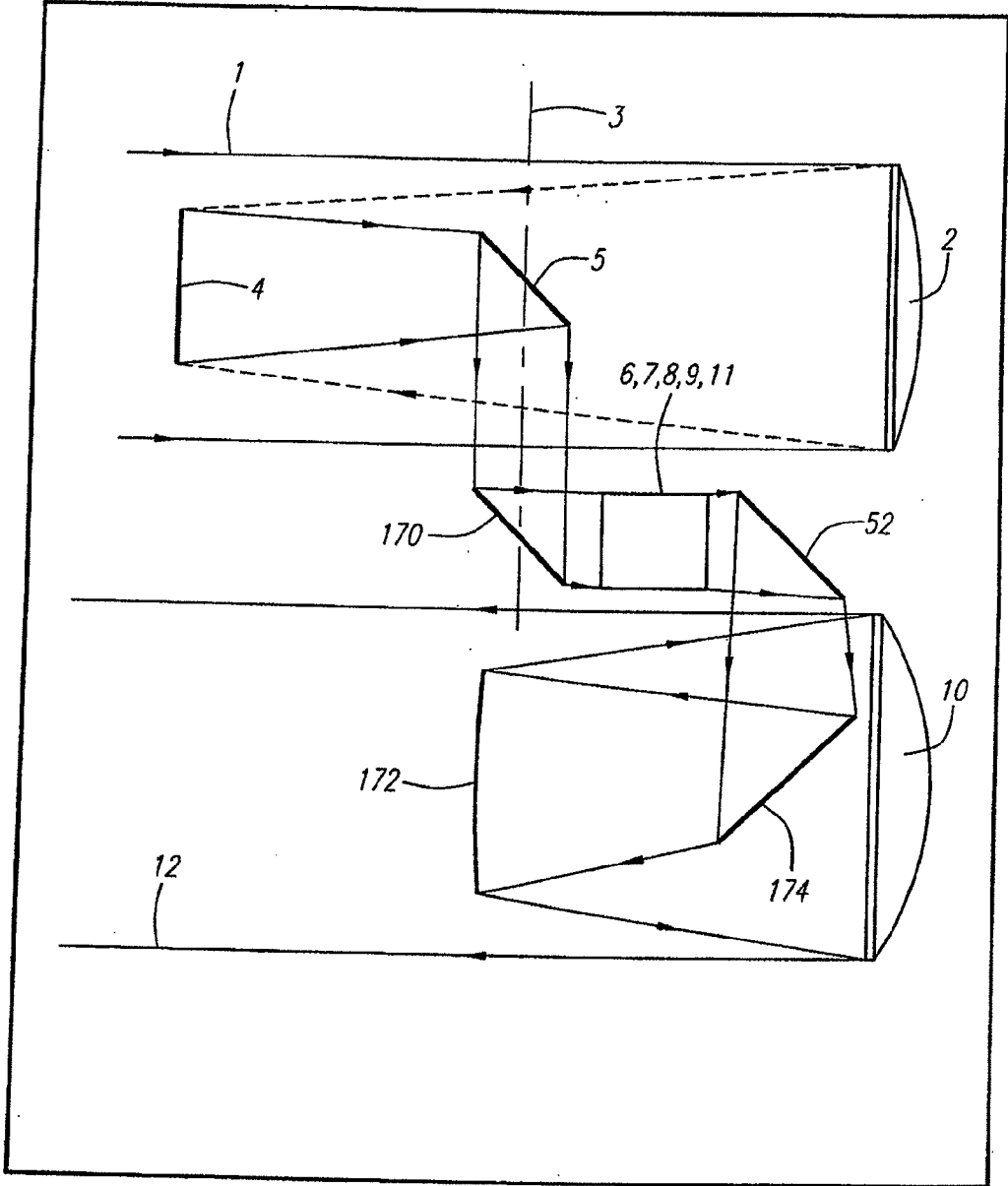
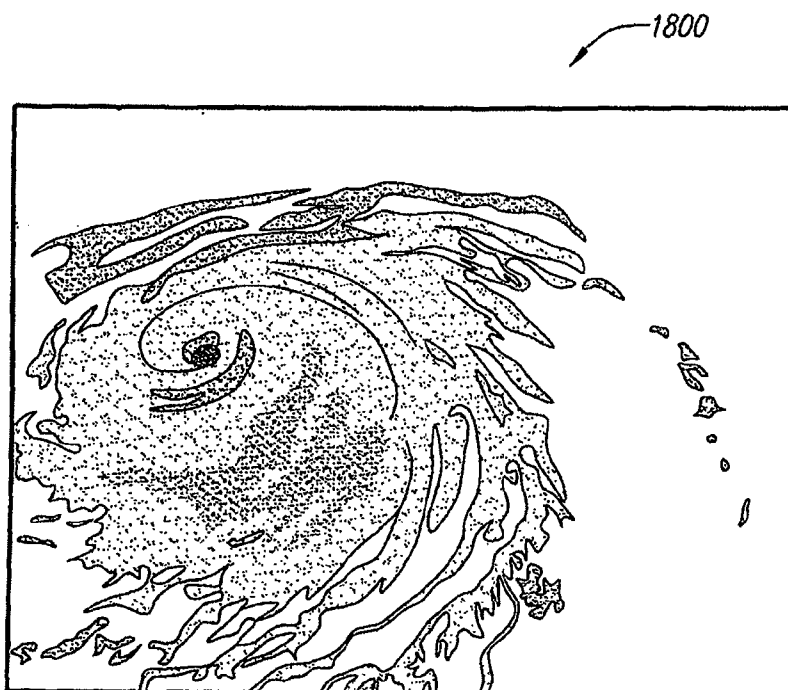

FIG. 17



HURRICANE

FIG. 18

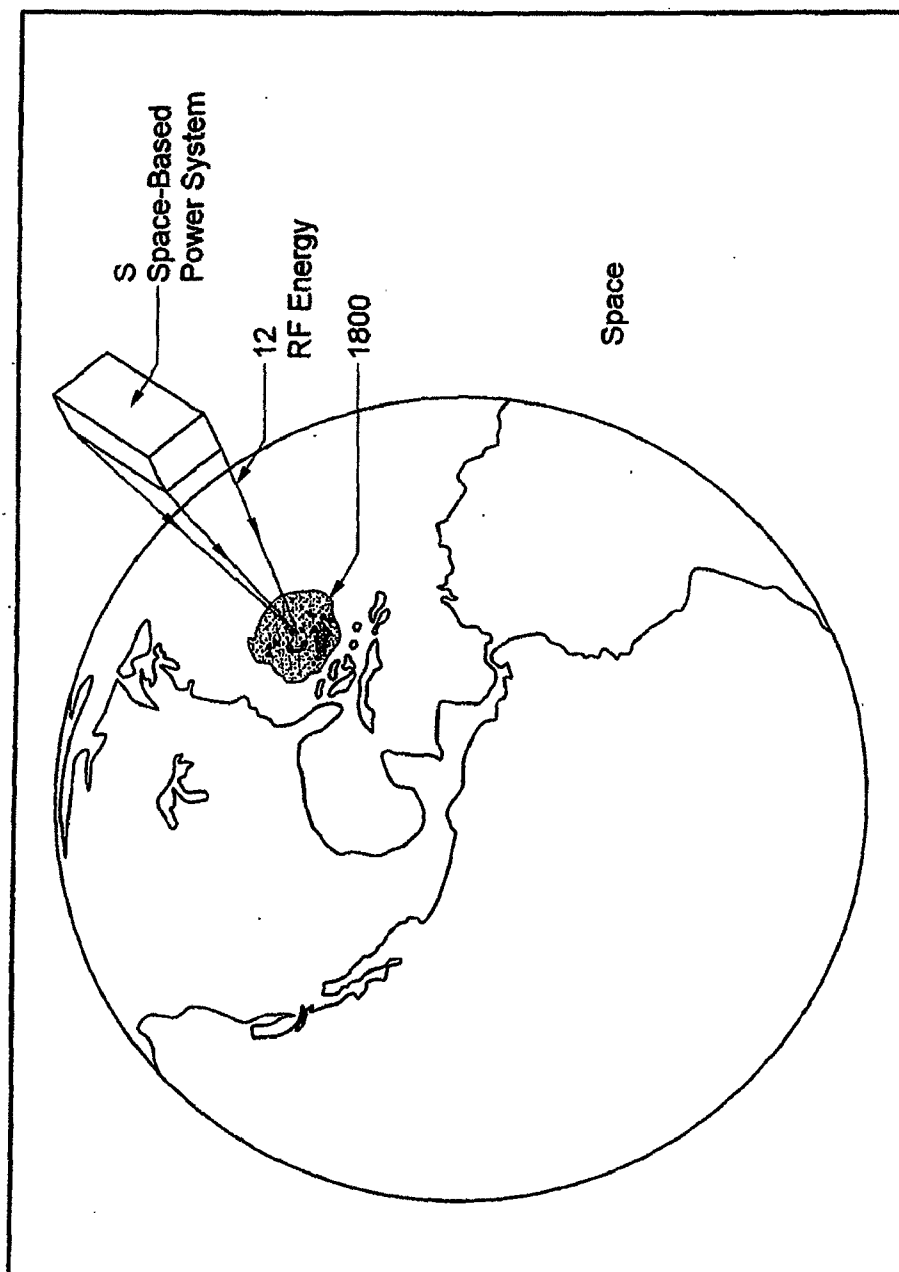

FIG. 19

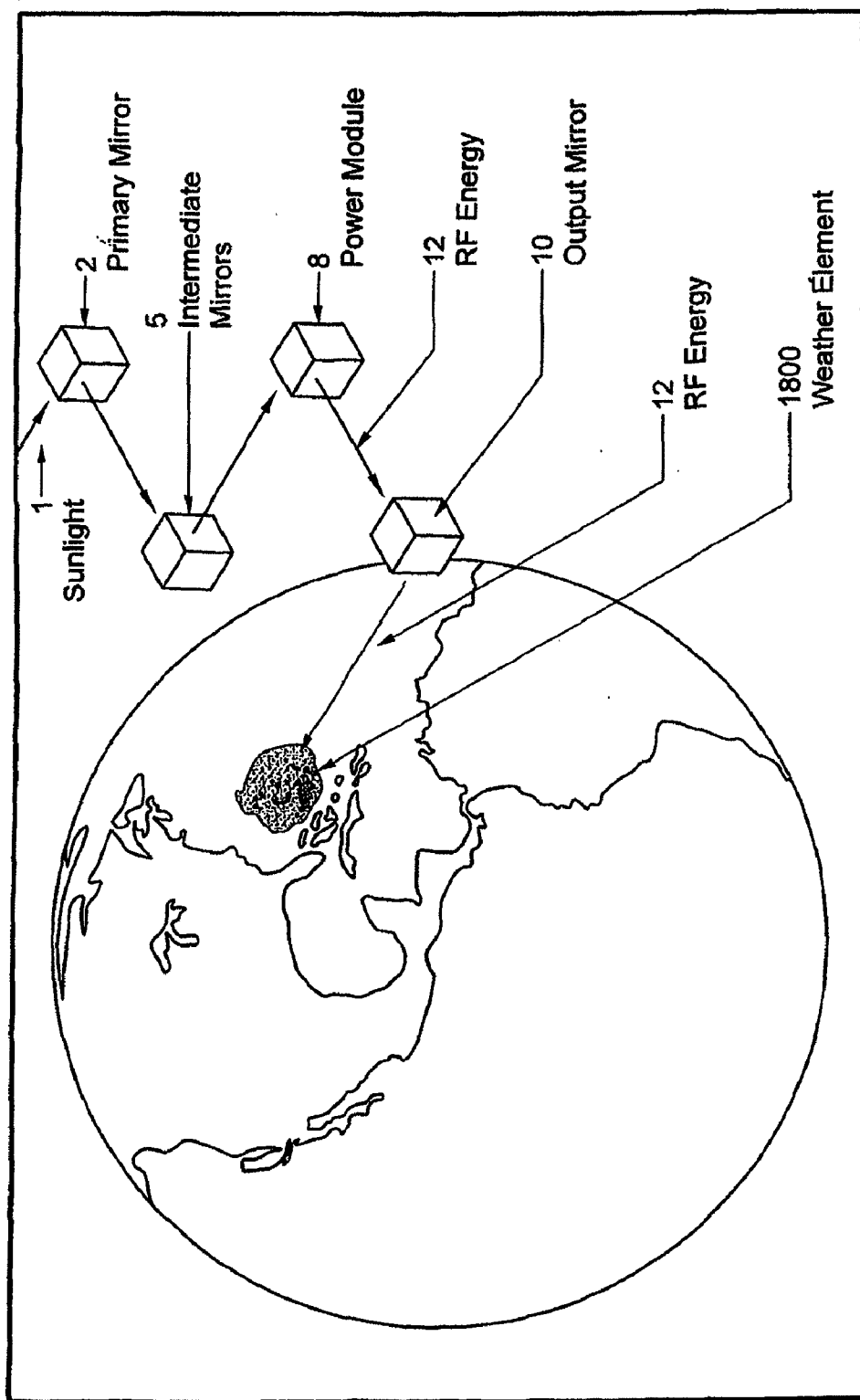
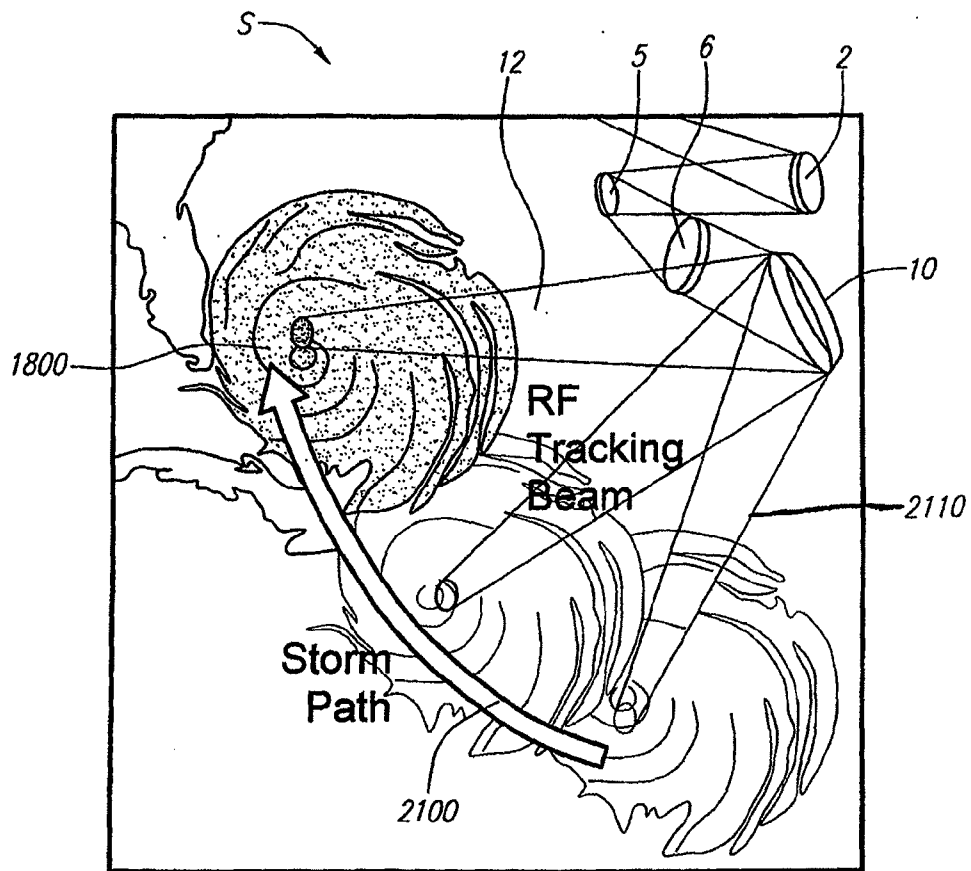
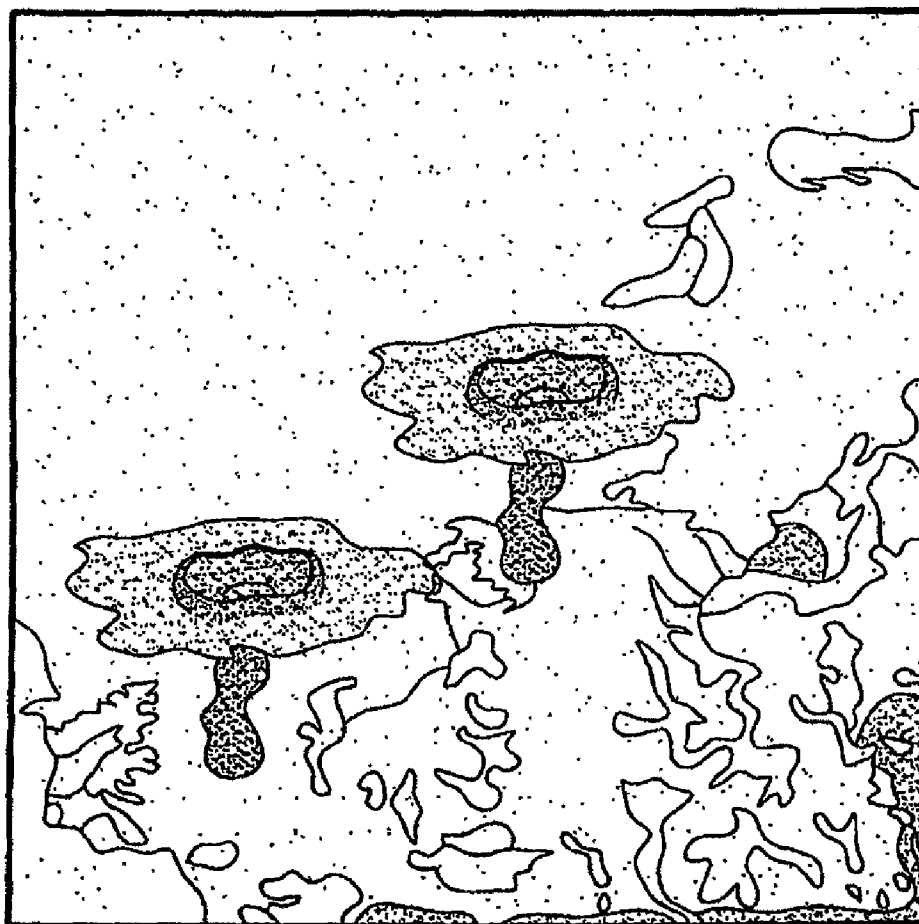

FIG. 20



Hurricane Reduction System (HURS)

FIG. 21



Groups of Thunderstorms

FIG. 22

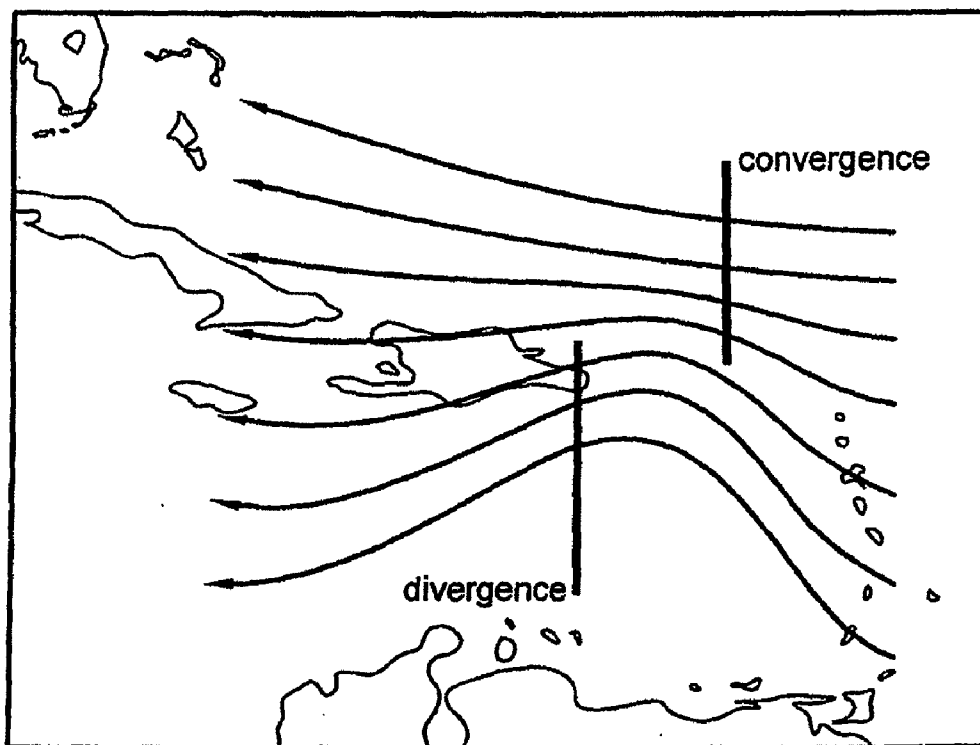

Mid-Latitude Frontal Boundaries

FIG. 23

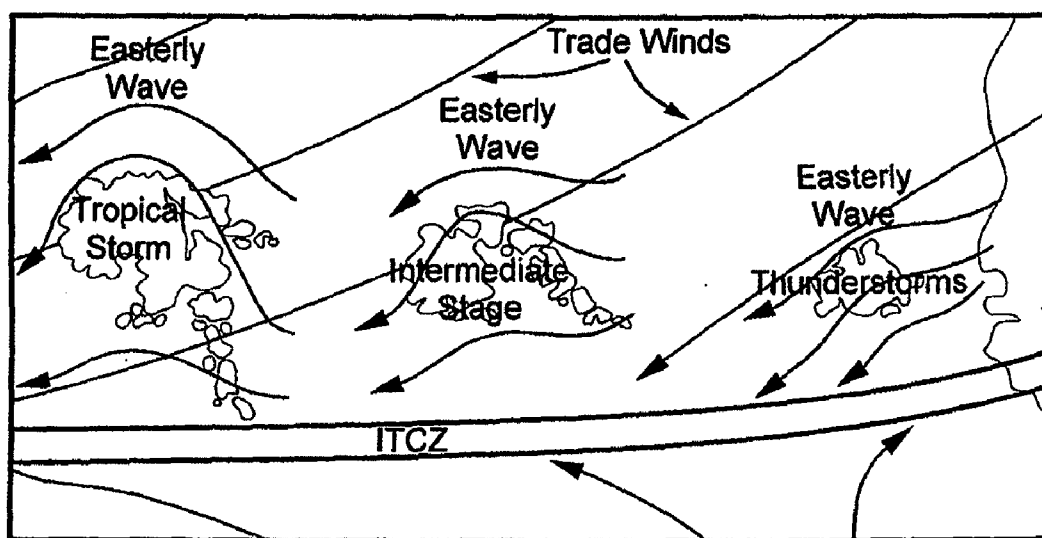

Easterly Atmospherics

FIG. 24

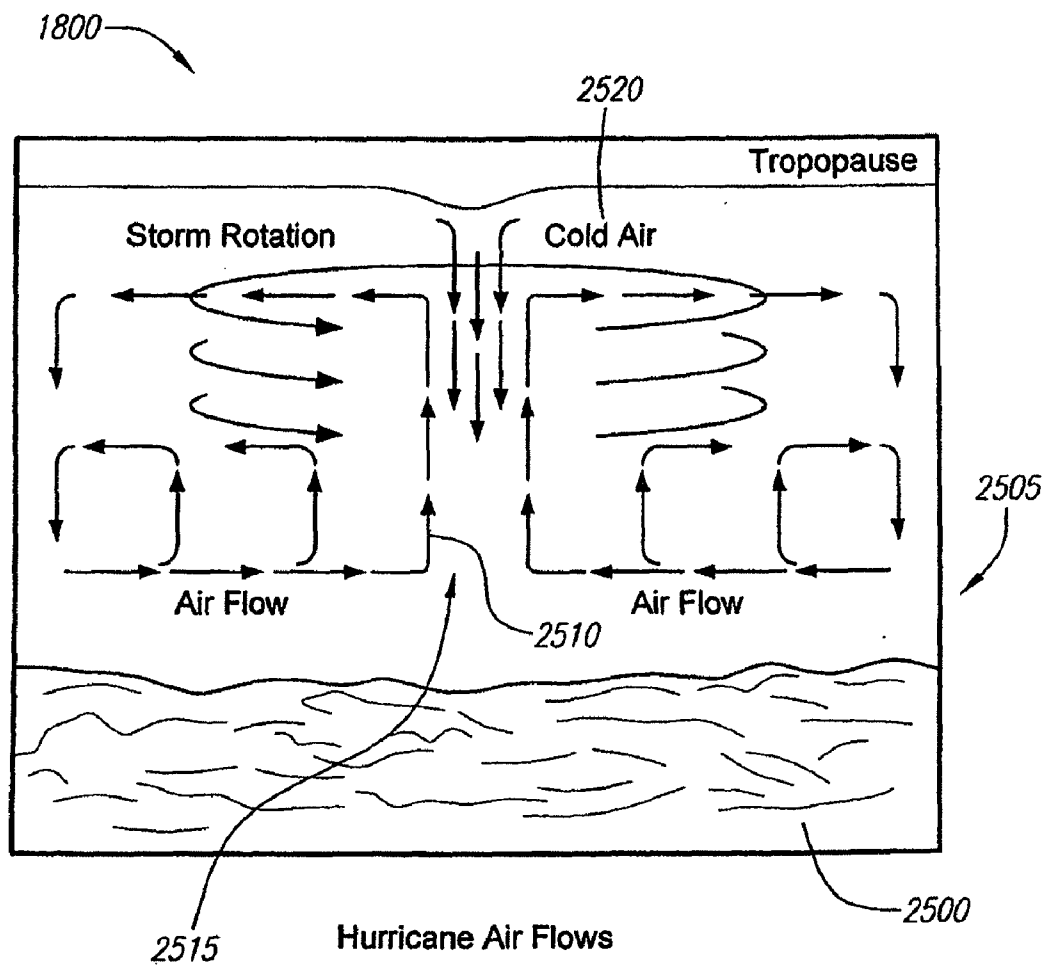
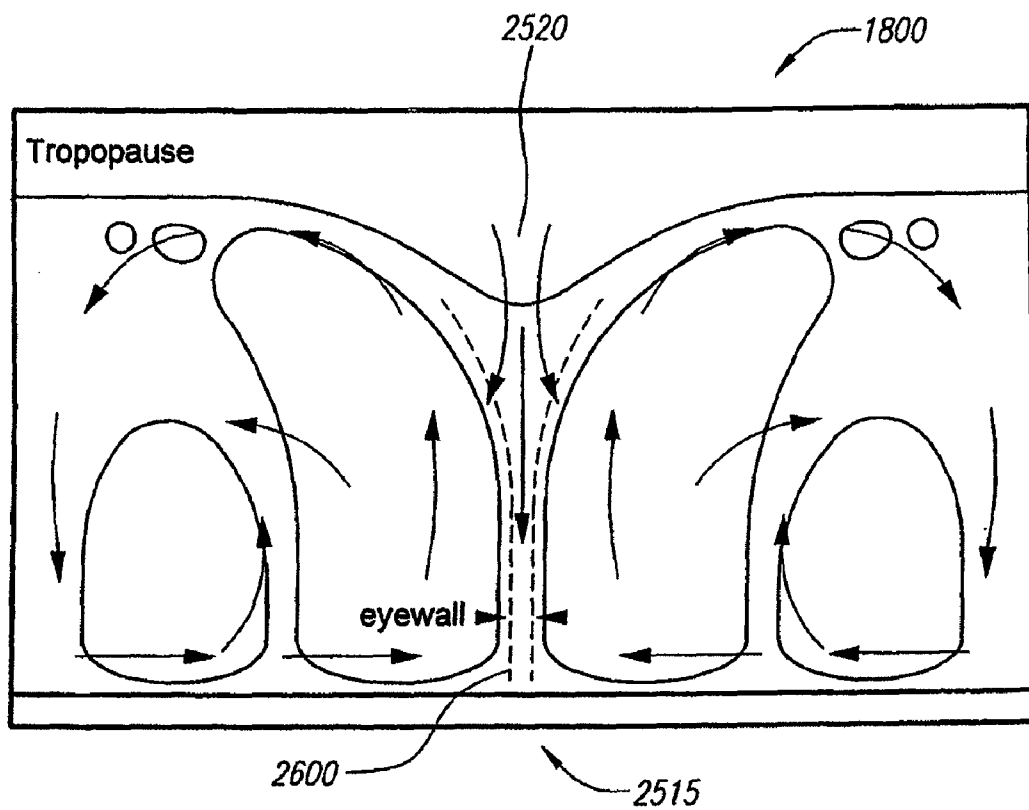

FIG. 25



Hurricane Air Flows

FIG. 26

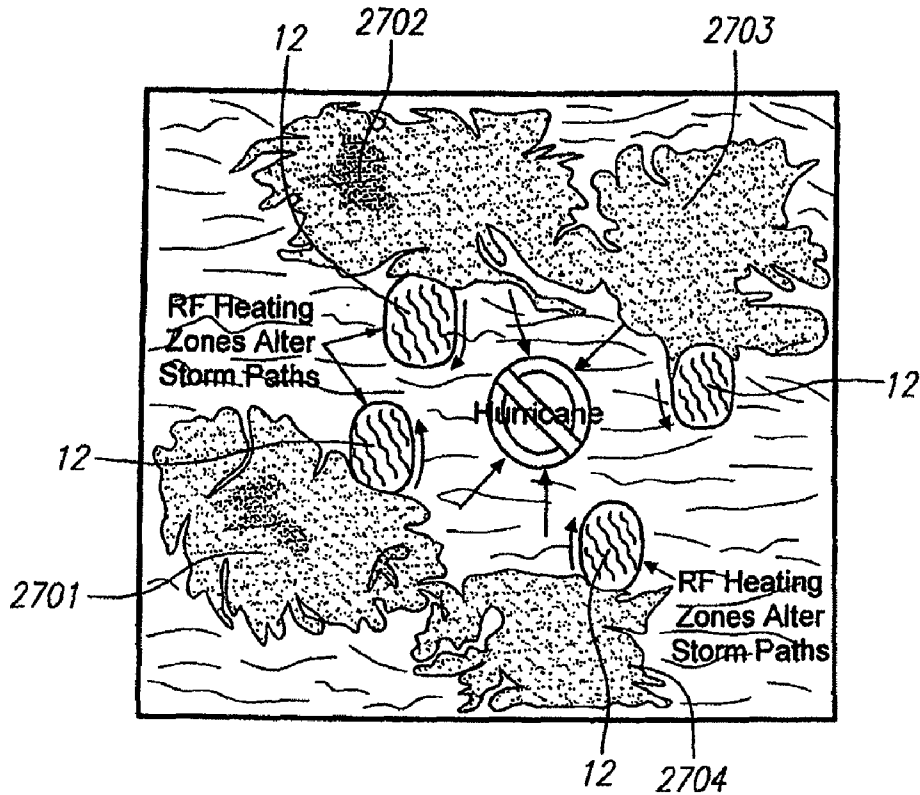

FIG. 27

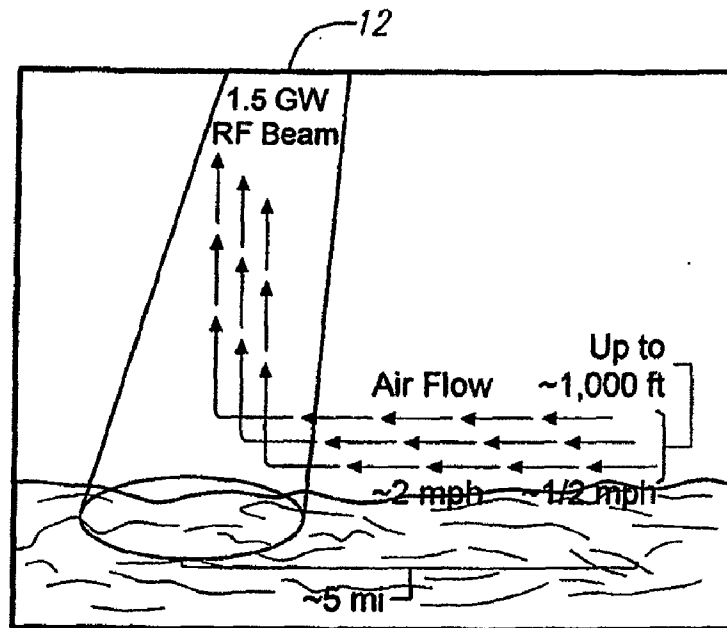

FIG. 28

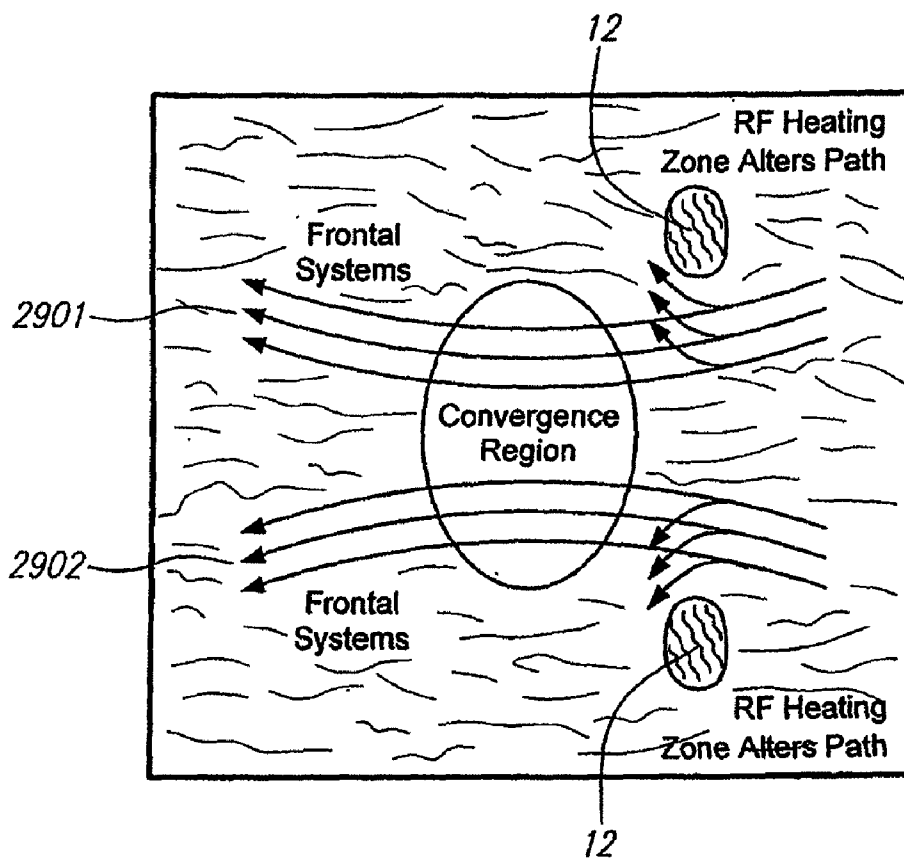
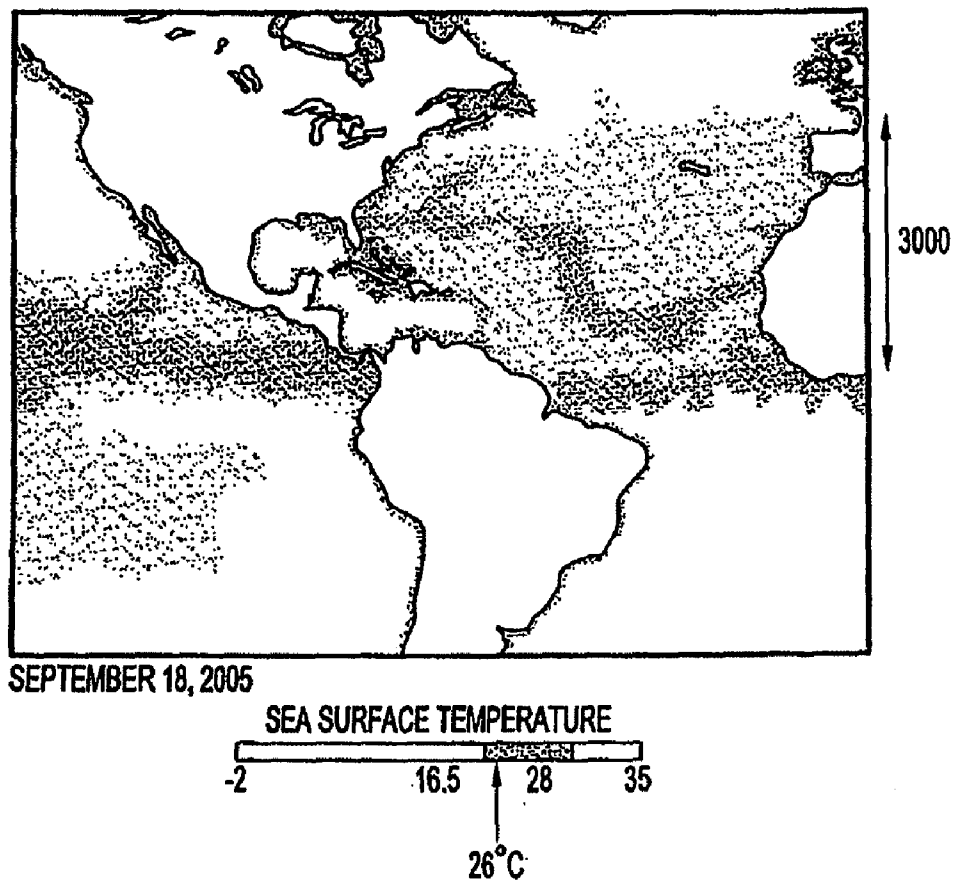

FIG. 29



Sea Surface Temperatures 8° to 20° North Latitude

FIG. 30

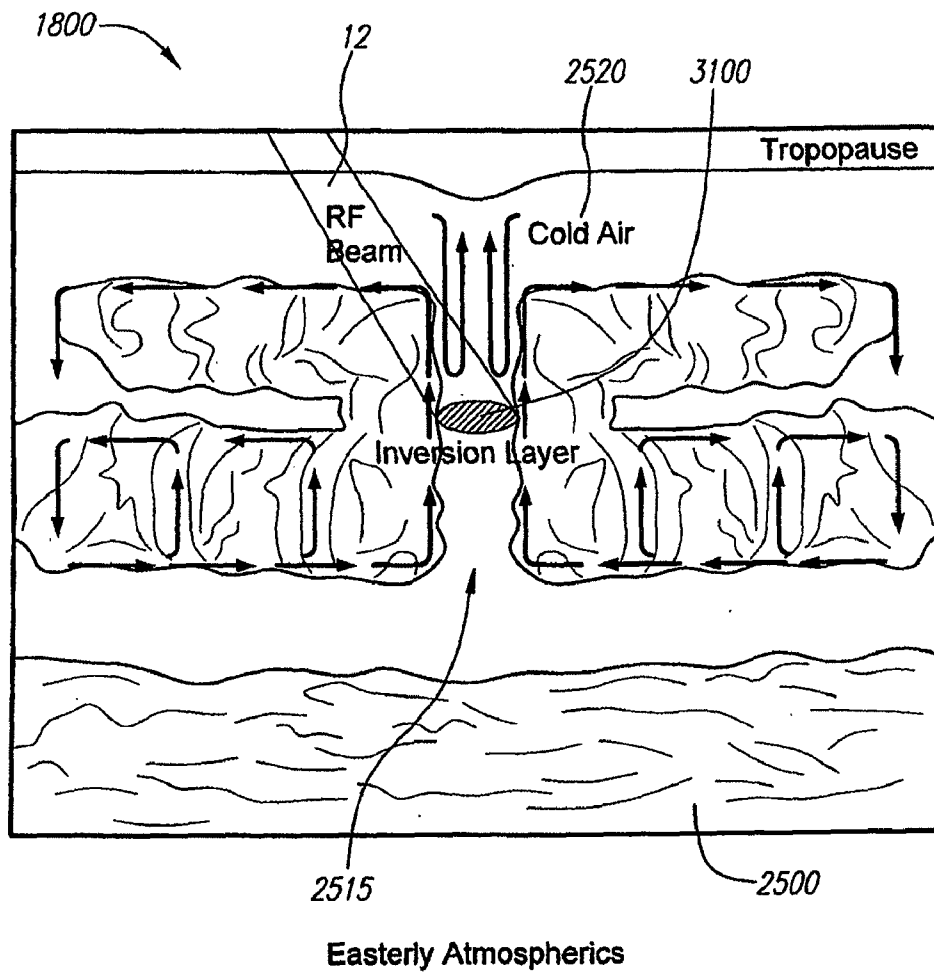

FIG. 31

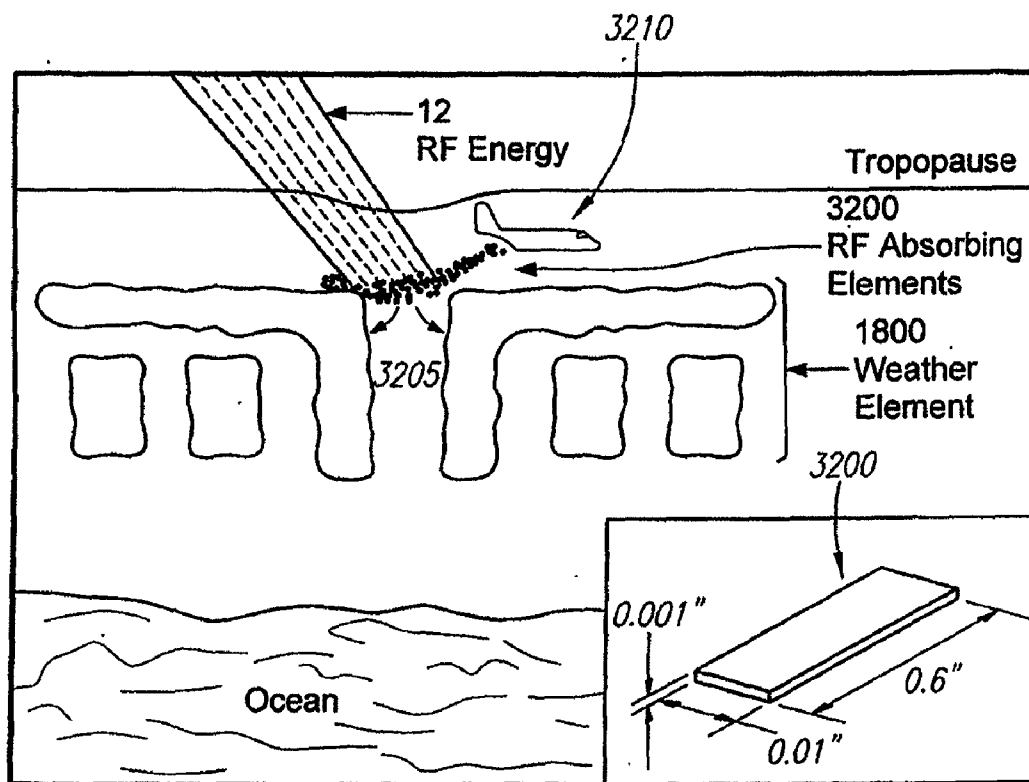

FIG. 32

WEATHER MANAGEMENT USING SPACE-BASED POWER SYSTEM

CROSS-REFERENCE TO RELATED APPLICATIONS

[0001] This application is a divisional of U.S. application Ser. No. 11/359,852, filed Feb. 22, 2006, which is a continuation-in-part of U.S. application Ser. No. 11/212,824, filed on Aug. 25, 2005, now U.S. Pat. No. 7,612,284, issued Nov. 3, 2009, which is a continuation of U.S. application Ser. No. 10/724,310, filed Nov. 26, 2003, now U.S. Pat. No. 6,936,760, issued Aug. 30, 2005, priority of all of which is claimed under 35 U.S.C. §120, and which claim priority under 35 U.S.C. §119 of U.S. Provisional Application No. 60/428,928, filed Nov. 26, 2002, the contents of all of which are incorporated herein by reference.

FIELD OF INVENTION

[0002] The present invention relates to space-based power systems and, more particularly, to altering weather elements, such as hurricanes or forming hurricanes, using energy generated by a space-based power system.

DESCRIPTION OF RELATED ART

[0003] Spaced-based power systems use the Sun's radiant power or solar flux to generate energy. The Sun's solar constant or flux is approximately 1.4 kW/m² in earth orbit. For example, in geosynchronous orbit or GEO (22,400 miles or 36,000 km from Earth), a space solar power system is almost continuously immersed in sunlight.

[0004] Solar cells, solar conversion devices, and nuclear power devices on a space power system generate Direct Current (DC) electricity, which is converted to a transmission frequency, such as radio, microwave and laser frequencies. For example, with Radio Frequency (RF) and microwaves, the generated electricity is converted to power through conversion devices, e.g. magnetrons, and focused by an antenna. The focused energy is directed to a receiver, and a receive antenna ("rectenna") converts the power beam into DC electricity. The DC electricity is converted into Alternating Current (AC) electricity, which is transmitted to a power grid for distribution to users.

[0005] As a result, some percentage of the solar constant is converted into usable electricity. For example, a 1 m² solar array with a conversion efficiency of 40% can produce about 560 watts of electrical power. One million square meters or a one square kilometer 40% efficient solar array can generate about 560 megawatts (MW) of power.

[0006] Concepts to harness solar energy were initially developed in the 1960s. In the 1970s and 1980s, NASA and the Department of Energy conducted satellite system studies, but the low efficiency and high costs of these systems precluded their effectiveness. In the 1990s, NASA conducted further studies and developed new concepts in different orbits. The new systems made improvements relative to earlier studies, however, existing concepts were still not economically viable.

[0007] A typical space power system has a power generation subsystem for energy conversion and a wireless power transmission subsystem. Known systems that use photovoltaic cells typically utilize large solar arrays to convert solar

energy into electricity. Connecting structures are typically used to maintain the correct relative positions of the system components.

[0008] Conventional space power systems can thus be improved. In particular, the connecting structures between power system components can be reduced or eliminated in order to reduce the weight of the system. In conventional systems, the connecting structures can comprise a majority of the weight of the systems. For example, some known systems utilize a transmit antenna in space having connecting structures that are many kilometers long and weigh millions of metric tons. The excessive weight of connecting structures can result in increased launch costs. Further, the excessive weight can strain system components, possibly impacting the alignment, operation and performance of the system. Thus, the weight of electrical and mechanical connections can be a limitation on the maximum size system that can be profitably implemented. Further, the positioning, orientation, and efficiency of system components can be improved, particularly system components that are not linked together with connecting elements.

[0009] Additionally, there exists a need for a system and method that can reduce the impact of weather elements. In particular, there exists a need for a system and method to weaken, or eliminate, hurricanes, typhoons and the like, such as the hurricane **1800** off of the coast of Florida shown in FIG. **18**.

[0010] Currently, there is no known system or method that effectively reduces the impact of weather elements, including large weather elements such as hurricanes and typhoons. The terms "hurricane" and "typhoon" are regionally specific names for a strong "tropical cyclone." "Tropical cyclone" is a generic term that refers to a non-frontal synoptic scale low-pressure system over tropical or sub-tropical waters with organized convection (i.e. thunderstorm activity) and cyclonic surface wind circulation.

[0011] Tropical cyclones with maximum sustained surface wind speeds of less than 17 m/s (34 kt, 39 mph) are generally referred to as "tropical depressions." Once a tropical cyclone reaches wind speeds of greater than 17 m/s (34 kt, 39 mph), they are typically called a tropical storm and assigned a name. If wind speeds reach 33 m/s (64 kt, 74 mph), then they are called various names in various regions, e.g., a "hurricane" (North Atlantic Ocean, Northeast Pacific Ocean east of the dateline, or the South Pacific Ocean east of 160E); "typhoon" (Northwest Pacific Ocean west of the dateline); "severe tropical cyclone" (Southwest Pacific Ocean west of 160E or Southeast Indian Ocean east of 90E); "severe cyclonic storm" (North Indian Ocean) and "tropical cyclone" (Southwest Indian Ocean). This specification generally refers to such storms as "hurricane" and more generally as a "weather element."

[0012] Mature hurricanes can be very powerful. For example, they can generate about 10,000 gigawatts of power, which can cause significant structural damage. Studies of windstorm damage for the East and Gulf regions of the United States indicate that average economic losses from such storms can average about \$5 billion. (R. A. Pielke Jr. and C. W. Landsea, (1998). "Normalized Atlantic hurricane damage, 1925-1995." *Weather Forecasting*, 13, 621-631). The National Oceanic and Atmospheric Administration (NOAA) estimates that hurricane-related damage from 1980 to 2002 is about \$84 billion. More recently, studies have estimated that economic losses from Hurricane Katrina exceed \$100 billion

(Risk Management Solutions), and with insured losses ranging from about \$10-\$25 billion (forecast before levee failure), and that losses from Hurricane Andrew were approximately \$44 billion (adjusted for inflation) (National Weather Service).

[0013] There is a need for a system and method that can reduce the impact or, or eliminate, weather elements, both large and small, including hurricanes. There is also a need for such a system and method that can be used in different geographic locations when needed. There is also a need for such a system and method that operates by solar energy so that the source of required energy is abundant. There is also a need for a system and method that can controllably direct energy to particular sections of a hurricane. Such a system and method could substantially reduce the economic and human losses caused by otherwise uncontrollable weather elements.

[0014] Embodiments of the invention fulfill these unmet needs.

SUMMARY

[0015] In one embodiment, a space-based power system that can be used to reduce the impact of weather elements includes a plurality of power system elements in space and a control system. One or more of the power system elements are free-floating in space. The control system maintains alignment of the free-floating elements. The plurality of elements are arranged to collect sunlight, generate electrical energy from the collected sunlight, and convert the electrical energy into a form that can be transmitted to a pre-determined location.

[0016] In another embodiment, a space-based power system a space-based power system that can be used to reduce the impact of weather elements includes a plurality of power system elements in space and a control system. One or more elements of the plurality of elements are free-floating in space. The power system elements include a primary mirror, an intermediate mirror, a power module, an emitter, and a reflective mirror. The primary mirror directs sunlight to the intermediate mirror. The intermediate mirror directs sunlight to the power module, which generates direct current electricity. The emitter converts the direct current electricity into RF or optical energy, and the reflective mirror transmits the RF or optical energy to a receiver at a predetermined location. The control system includes a plurality of sensors and a plurality of displacement members. Each element in space includes a sensor and a displacement element, and the control system maintains alignment of the free-floating elements in space by selectively activating a displacement member in response to sensor data.

[0017] A further embodiment is directed to a method of aligning power system elements that can be used to reduce the impact of weather elements to generate power in space and transmit the generated power to a predetermined location. The embodiment includes launching a plurality of elements and a control system into space, in which one or more elements of the plurality of elements are free-floating in space, positioning the elements in space, maintaining alignment of the free-floating elements using the control system so that the power system elements are configured to collect sunlight, generate electrical energy from the collected sunlight, and convert the electrical energy into a form suitable for transmission to the pre-determined location.

[0018] In various embodiments, the power system elements can have different mirrors and mirror configurations, e.g., a

foldable mirror, a spherical mirror, a mirror supported by an inflatable tube or a membrane, mirrors having optical coatings to reduce photon pressure or maintain the shape of the mirror. The power system elements can include a primary mirror, a first intermediate mirror, a power module, an emitter, and a reflective mirror. The first intermediate mirror directs sunlight to the power module, and the power module generates electrical energy. The emitter converts the generated electrical energy into a form that can be transmitted and provides it to the reflective mirror, which transmits the converted energy to a receiver at the predetermined location. Also with system and method embodiments, a concentrator is used to focus the sunlight from the intermediate mirror onto the power module.

[0019] Embodiments can utilize different power modules, e.g., photovoltaic and thermoelectric power modules. With photovoltaic modules, the solar cells can be co-located with the emitter. The converted energy or energy that is transmitted can be radio frequency or optical energy.

[0020] The control system in embodiments can adjust an alignment of one or more system elements by adjusting a position, orientation of the elements. The system includes a plurality of sensors, such as alignment or distance sensors. Data of sensors of two elements is compared to determine whether the two elements are properly aligned and located at an acceptable distance using, for example, radar, lidar, interference patterns, a solar wind, electro-static forces. It also adjusts the alignment of the elements. The control system can include a displacement element, such as a thruster, to adjust the alignment of a system component. Also in system and method embodiments, different numbers of elements, e.g., a majority or all of the elements, are free-floating in space.

[0021] In accordance with another embodiment of the invention, energy from a space-based power system can be used to alter a weather element to weaken or dissipate a weather element.

[0022] Another embodiment is directed to a method of altering weather using space-born energy that includes generating RF energy in space using a space-based power system, focusing the generated energy to a diameter of about 1 km to about 10 km and applying at least about 10^9 watts/km² of focused energy to a weather element. The energy alters a temperature of a section of the weather element and weakens the weather element.

[0023] A further alternative embodiment is directed to a method of altering weather using space-born energy by generating RF energy in space using a space-based power system, focusing the generated RF energy to a diameter of about 5 km and applying at least about 10^9 watts/km² of focused RF energy to a weather element. The energy alters an airflow of the weather element, thereby weakening the weather element.

[0024] In another alternative embodiment, a method of altering weather using space-born energy includes generating RF energy in space using a space-based power system, focusing the generated RF energy to a diameter of about 5 km and applying at least about 10^9 watts/km² of focused RF energy to a weather element to change a path of the weather element.

[0025] In a further alternative embodiment, a method of altering weather using space-born energy includes inserting one or more energy absorbing elements into a weather element, generating RF energy in space using a space-based power system, focusing the generated RF energy and directing focused RF energy to one or more energy absorbing elements. Energy absorbing elements absorb RF energy at

least about 10^9 watts/km² and transfer resulting thermal energy to a weather element to alter and weaken the weather element.

[0026] According to another embodiment, a space-based power system for altering weather includes a plurality of power system elements in space and a distributed control system that maintains alignment of one or more free-floating power system elements. One or more power system elements are free-floating. The power system elements include at least one intermediate power system element in space that receives sunlight from one power system element in space and transmits the sunlight to another power system element in space. The power system elements in space include a control system component of the distributed control system, and the control system maintains alignment of free-floating power system elements based on communications between control system elements of adjacent power system elements. The power system elements are arranged to collect sunlight, generate electrical energy from the collected sunlight, and convert the electrical energy into RF energy, which is applied to a weather element and alters and weakens the weather element.

[0027] In various embodiments, the RF energy generated in space can have a frequency of about 2 GHz to about 12 GHz and be applied to a weather element having a diameter of about 1 km to about 10 km. The amount of energy that is applied to a weather element can be about 10^9 watts/km² of energy. The energy can be applied to different locations, e.g., the eye of the hurricane, typhoon, tropical cyclone, cyclonic storm or other weather element, to alter and/or dissipate the weather element. Further energy can be applied to or adjacent to weather elements, such as thunderstorms, that can form into more serious and mature weather elements. The energy can alter air flows, change the direction of the weather element and create temperature gradients or inversion layers, e.g., temperature increases of about 2° C. to about 12° C. Energy absorbing elements can be introduced into a weather element. These absorbing elements absorb RF energy and convert it to thermal energy, which is applied to the weather element to achieve these results. For example, energy absorbing elements can be aluminum oxide, plastic or other suitable RF absorbing materials. The absorbing elements can be coated to facilitate thermal energy transfer. One suitable coating is an iron oxide coating. These elements are constructed such that their surface area to mass ratio is large in order to minimize their sink rate, thereby allowing them to “float” with an air mass. The energy absorbing elements are preferably substantially buoyant with the weather element.

BRIEF DESCRIPTION OF THE DRAWINGS

[0028] Referring now to the drawings, in which like reference numbers represent corresponding parts throughout, and in which:

[0029] FIG. 1A illustrates an embodiment of a spaced-based power system with free-floating components,

[0030] FIGS. 1B-D illustrate views an embodiment of a system to control the positioning and alignment of power system components;

[0031] FIG. 1E illustrates an alternative embodiment having a phased array antenna;

[0032] FIGS. 2A-B illustrate plan and cross-sectional views of a collector or primary mirror;

[0033] FIG. 3 is a cross-sectional view of coatings on a mirror of the system;

[0034] FIGS. 4A-D illustrate different views of mirrors that are supported by an inflatable structure;

[0035] FIG. 5 is an illustration of an embodiment using inflatable mirrors and membrane elements;

[0036] FIG. 6 is an illustration of an embodiment using inflatable mirrors and membrane elements;

[0037] FIG. 7 is an illustration of an embodiment using inflatable mirrors and membrane elements;

[0038] FIG. 8 is an illustration of a further embodiment using inflatable mirrors and membrane elements;

[0039] FIG. 9 is an illustration of an embodiment of a generation subsystem having a photovoltaic power module and solar concentrators;

[0040] FIG. 10 is an illustration of an embodiment having a photovoltaic power module and multiple solar concentrators;

[0041] FIG. 11 is an illustration of an embodiment of a generation subsystem having a power cable to connect solar cells and photovoltaic module components;

[0042] FIG. 12 illustrates an embodiment of a wireless transmission system;

[0043] FIG. 13 illustrates another embodiment of a wireless transmission system;

[0044] FIG. 14 illustrates an embodiment of a space-based power system having a mirror and a power module that provides an output directly to a reflecting mirror;

[0045] FIG. 15 shows an embodiment of a space-based power system having a power module that is positioned between intermediate mirrors;

[0046] FIG. 16 illustrates an embodiment of a space-based power system having two intermediate mirrors in each of the generation and transmission subsystems;

[0047] FIG. 17 illustrates an embodiment of a space-based power system having three intermediate mirrors in each of the generation and transmission subsystems.

[0048] FIG. 18 is a satellite image of a hurricane off the coast of Florida;

[0049] FIG. 19 illustrates a spaced-based power system for generating energy that is applied to a weather element according to one embodiment;

[0050] FIG. 20 illustrates an exemplary space-based power system that can be used with embodiments;

[0051] FIG. 21 illustrates an exemplary space-based power system that tracks a hurricane along a storm path and applies energy to the hurricane at different times to alter and disrupt the hurricane according to one embodiment;

[0052] FIG. 22 illustrates thunderstorms that can form in tropical depression;

[0053] FIG. 23 convergence of frontal boundaries that can form a tropical depression;

[0054] FIG. 24 illustrates easterly atmosphere waves that can converge to form a tropical depression;

[0055] FIG. 25 illustrates air flows of a hurricane;

[0056] FIG. 26 further illustrates air flows of a hurricane;

[0057] FIG. 27 illustrates application of energy to thunderstorms to prevent or weaken a weather element according to one embodiment;

[0058] FIG. 28 illustrates application of RF energy to an air flow according to one embodiment;

[0059] FIG. 29 illustrates application of energy to frontal systems to prevent or weaken a weather element according to one embodiment;

[0060] FIG. 30 illustrates geographic areas having the highest frequency of hurricanes;

[0061] FIG. 31 illustrates application of energy to a eye of a hurricane to form an inversion layer and alter air flow according to one embodiment; and

[0062] FIG. 32 illustrates RF absorbing elements or chaffs being introduced into a weather element according to one embodiment, and the insert illustrates one configuration of an RF absorbing element that can be used with embodiments.

DETAILED DESCRIPTION OF ILLUSTRATED EMBODIMENTS

[0063] Embodiments of a space-based power system with one or more free-floating or free-flying system components that can be aligned and a system and method of managing weather using a space-based power system and embodiments of a space-based power system include components that can be aligned while substantially reducing or eliminating connecting structures between system components, and using a control system to provide for alignment and positioning of free-floating system components will now be described. Energy from space-based power systems can be used to alter a weather element, such as a hurricane, by introducing energy that creates a temperature gradient, alters air flows and/or steers a weather element in a different direction, thereby weakening or dissipating the weather element and reducing or preventing damage that would otherwise occur with a stronger storm.

[0064] Referring to FIG. 1A, one embodiment of a space-based power system "S" includes power generation and transmission components. One embodiment of a system includes a primary or collection mirror 2, which orbits about axis 3, intermediate mirrors 4 and 5, a panel 11 with concentrators 6, an optical or power module 8 with solar cells 7, a transmitter feed or emitter 9, and a transmission subsystem that can include, for example, a reflector or output mirror 10 and one or more other mirrors as necessary. A control system 13 adjusts the shape, position, orientation and alignment of the power system components.

[0065] This specification generally refers to adjusting the alignment of system components for purposes of explanation, but the alignment can include a shape, a position, an orientation and other adjustments that can affect the alignment of system components. The system elements are arranged to collect sunlight, generate electrical energy from the collected sunlight, and convert the electrical energy into a form that can be transmitted to a receiver 14 at a pre-determined location 15, such as Earth or another location, where it is converted and distributed to users.

[0066] More specifically, the system components are positioned so that sunlight 1 is incident upon the primary mirror 2. The primary mirror 2 can be, for example, a nearly spherical mirror. The primary mirror 2 can be various sizes, e.g., having a diameter of about 1 km to about 2 km. The primary mirror (and other mirrors as described below) can be supported by a structure. For example, referring to FIGS. 2A-B, an inflatable tube or toroid 24 (generally 24) can surround the mirror 2. The tube 24 may be inflated using chemical or gas air tanks or other inflation systems.

[0067] Referring to FIGS. 2 and 3, one embodiment of a primary mirror 2 includes a substrate 20, such as a plastic substrate, that is coated with one or more films or optical coatings 22. The optical coatings reflect selected portions of sunlight 1 (e.g., particular wavelengths) that are most suitable for use by the solar cells 7. The selective reflection also reduces the photon force upon the mirror 2. Persons of ordi-

nary skill in the art will recognize that various suitable substrate and coating combinations can be utilized for different mirror configurations and reflectivity and solar cell requirements.

[0068] Referring again to FIG. 1A, the sunlight 1 is reflected by the primary mirror 2 to a first intermediate mirror 4, such as a flat folding mirror. The mirror 4 tracks the orientation of the primary mirror 2 so that the two mirrors 2 and 4 remain in alignment. The first fold mirror 4 reflects the incident sunlight 1 onto a second intermediate mirror 5, such as a fold mirror. The second fold mirror 5 can be identical to the first fold mirror 4 or have another suitable design.

[0069] For example, referring to FIGS. 4A-D, a mirror in the space-based power system can be a flat mirror that includes a plastic substrate 40 and a coating 42, e.g., the same coating as the coating 22 on the primary mirror 2. For example, having the same coatings on the mirrors 2, 4, and 5 reduces the heat load on the solar cells 7. The coating 42 also reduces the solar photon pressure on the fold mirror. The mechanical residual stress in the coating can be set to the value needed to counteract the solar photon pressure, and maintain an optically flat surface. FIG. 4 also illustrates that the mirrors can also include inflatable supports 44.

[0070] Referring again to FIG. 1A, the mirror 4 rotates about the axis 3, and the mirror 5 tracks the concentrators 6. With proper maneuvering, the first fold mirror 4 reflects the incident sunlight 1 onto the second fold mirror 5. The second mirror 5 reflects light to one or more concentrators 6, such as non-imaging concentrators. The concentrators 6 magnify and smooth out spatial irregularities in the reflected beam of sunlight 1 received from the second fold mirror 5. The output of the concentrators 6 is directed to solar cells 7 of an RF or optical power module 8. Using concentrators allows an entire solar cell wafer to be utilized, resulting in more efficient energy production.

[0071] Various concentrator 6 focal lengths can be used to obtain the correct magnification of sunlight onto the solar cells 7 or other conversion devices. For example, the sun typically subtends an angle of approximately 0.5 degree at 1 a.u. (the distance from the sun to the earth). Thus, for example, the size of the focal spot could be 0.00873 times the focal length of the system.

[0072] Persons of ordinary skill in the art will recognize that various power modules can be utilized with different embodiments and systems. For example, as shown in the Figures, the power module is a photovoltaic power module that utilizes solar cells. Alternative power modules include turbines, heat engines, and nuclear sources. A further alternative power module is a thermoelectric power module. A thermoelectric power module utilizes a temperature gradient, e.g., warmer front surfaces and cooler rear surfaces that result in a junction between two surfaces to generate electricity. For purposes of explanation and illustration, but not limitation, this specification refers to photovoltaic power modules with solar cells 7.

[0073] In one embodiment, the solar cells 7 are mounted near an input electrode of the modules 8. Thus, electrical cables from the solar cells 7 to the modules 8 are not needed. Eliminating these connectors reduces the mass of the system. Further, power losses in the system are reduced by reducing or eliminating power losses due to resistive (I^2R) heating in connecting cables. This arrangement also eliminates the need for other components typically associated with components connectors, such as insulation. Eliminating these components

also reduces the weight of the power module, increases the performance of the cells, and reduces the cost of the cells.

[0074] The spacing arrangement of the solar cells 7 also allows heat to be conducted to the thermal panels 11, which radiate heat to space. Also, the concentrators 6 provide for dedicated solar cells 7 for each RF or optical power module 8. Thus, the concentrators provide for efficient use of incident sunlight 1. This arrangement is also advantageous since the solar cells are co-located with an energy conversion device, thus reducing the length of or eliminating connectors between these components. Co-location of these components is not practicable in typical known systems using connecting structures because of the need for the concentrator to track the Sun while the RF or optical section remains pointed at the Earth a user's substation.

[0075] The concentrators 6 with the fold mirror 5 shield the solar cells 7 from direct view of space and thus protect the solar cells 7. More specifically, the solar cells are mounted on the power module, and the concentrators are mounted above the cells, thus shielding the solar cells from a direct view of space except for a small solid angle centered on the incoming sunlight. The second fold mirror acts as a shield in this last direction so that the solar cells are shielded in all directions, eliminating the need for solar cell cover slips (e.g., glass) and other protective coverings. As a result, the weight of the power system is further reduced by eliminating these components.

[0076] DC electrical power generated by the solar cells 7 is converted by the RF or optical power modules 8 into a form that can be transmitted, such as RF or optical power. The RF or optical power is radiated by the RF feeds or optical emitters 9 to the RF reflector, output mirror 10 (generally reflector 10), or directly to the predetermined location. For example, the RF feeds or optical emitters 9 can be arranged in a direct radiating array or a phased array antenna 19 (FIG. 1E), thus eliminating the need for a reflector 10. Waste heat from the solar cells 7, power modules 8, and RF feeds or optical emitters 9 is radiated into space by the thermal panels 11.

[0077] The reflector 10 is constructed so that the coating or incident surface reflects power to Earth or another predetermined location or station, and transmits sunlight. By transmitting sunlight 1, the photon pressure on the reflector 10 is reduced or nearly eliminated. Since the reflector 10, may be as large as the primary mirror 2, reducing photon pressure results in a significant reduction in fuel that is needed for station-keeping of the reflector 10. However, as with the primary mirror 2, the residual photon pressure, in conjunction with the selected residual mechanical stress of the coating that reflects power and transmits sunlight 1, can be used to maintain the correct shape of the reflecting surface. This arrangement can reduce the weight of the reflector 10, for example, up to about 66% or more. Alternatively, an optical mirror 10 is constructed so that the coating reflects the desired optical wavelengths and transmits unwanted solar radiation.

[0078] The RF or optical power 12 reflected by the reflector or mirror 10 can be a diffraction-limited beam that is generally focused and directed to a terrestrial antenna or collector 14 located on Earth or another desired location 15. A set of RF/optical sensors at the antenna or collector measure the beam waveform shape and boresight. A feedback circuit 17 computes aspects of the received beam and send control signals back to the control system to adjust the alignment of one or more components, e.g., adjust the shape, position, or orientation of a component.

[0079] For example, if the emitters 9 and reflector 10 are not properly aligned, one or both of these components can be adjusted so that a beam 12 reflected from the reflector 10 is directed towards the receiving antenna 14. As a further example, the shape of the emitters 9 can be adjusted.

[0080] The proximity control system 13 or a separate control system is used to adjust the alignment of various power system components, for example, a primary or transmission mirror, an intermediate mirror, such as a fold-mirror, a reflector, a sub-reflector, and an antenna feed. The control system can also maintain the shape of the wave front of the transmitted electromagnetic wave. Other activities that can be performed by the control system include active mirror control, phase conjugation, and active antenna control.

[0081] In one embodiment, the control system 13 includes a sensor system and a displacement system to adjust the alignment of one or more system components in response to sensor data. Persons of ordinary skill in the art will recognize that a space-based power system can have different numbers of free-floating system elements. For example, one or more, most, or all of the elements can be free-floating in space. The control system can be configured to adjust the alignment of the free-floating elements, and elements that are not free-floating (e.g., tethered to other elements). This specification, however, refers to the control system aligning free-floating power system elements for purposes of explanation, but not limitation. For example, data from control system elements or sensors, such as radar and lidar sensors, can indicate the alignment of two or more components. The displacement system can include one or more thruster elements that can be activated or de-activated in response to the sensor data to adjust the alignment.

[0082] Referring to FIG. 1A, in one embodiment, the proximity control system is located in space and generally includes control units or sensors 2a,b (generally 2a), 4a,b (generally 4a), 5a,b (generally 5a), 8a,b (generally 8a), 10a,b (generally 10a), and thrusters 2d,e (generally 2d), 4d,e (generally 4d), 5d,e (generally 5d), 8d,e (generally 8d), and 10d,e (generally 10d) on respective power system components 2, 4, 5, 8, and 10. The embodiment shown in FIG. 1A is merely illustrative of various proximity control configurations that utilize different numbers and positioning of proximity control system components.

[0083] For example, referring to FIGS. 1B-D, in another embodiment, the primary mirror 2 includes four sensors, and the intermediate mirrors 4 and 5 include eight sensors. FIGS. 1C and 1D illustrate cross-sectional views showing one possible sensor arrangement. In the illustrated embodiment, four proximity control system sensors 2a on the primary mirror 2 and a corresponding four sensors 4a on the mirror 4 are arranged to look at or communicate with each other. Similarly, four additional proximity control system sensors 4a on the mirror 4 and corresponding four sensors 5a on the mirror 5 are arranged to communicate with each other. Four additional units 5a on the mirror 5 and four units 8a on the module 8 are arranged to communicate with each other. Additionally, four units 9a on the emitters 9 and four units 10a on the reflector 10 are arranged to communicate with each other.

[0084] With this configuration, three sensor units can be utilized, with the fourth unit in a group serving as a back-up unit. The fourth unit can also be used to resolve anomalous behavior of other units. Further, if only one sensor unit is utilized, the other three units can be used to cross-check the first unit.

[0085] Thus, in the illustrated embodiments, the control system makes adjustments based on communications between sensors of adjacent elements, i.e., elements that communicate with each other by reflecting or receiving sunlight or other signals. For example, the primary mirror **2**, fold mirrors **4** and **5**, optical module **8** and reflector **10** can all include sensors. The sensors on the mirrors **2** and **4** communicate with each other, the sensors on the mirrors **4** and **5** communicate with each other, the sensors on the mirror **5** and the optical module **8** communicate with each other, and the sensors on the optical module **8** and the reflector **10** communicate with each other. The control circuit is configured to adjust a system component based on the alignment of the previously described pairs of components. Adjustments can be made based on alignments of other numbers and combinations of system components.

[0086] Thus, for example, in response to sensor data between mirrors **2** and **4**, thrusters on the mirror **4** may be activated (or de-activated) to re-align the mirror **4** with respect to mirror **2**. Similarly, thrusters on mirror **2** can be activated (or de-activated). After re-aligning one system component, one or more other system components can also be re-positioned to maintain proper alignment of the entire system. A monitoring system on Earth or another planet, body or station can also monitor and alter the alignment of system components.

[0087] In one embodiment, a proximity control system **13** uses complementary and redundant position-measuring devices, such as stereoscopic cameras, modulated laser diodes, and lasers. For example, lasers can form a closed loop of optically coherent beams, such that a change in relative positions and orientation of the system components produce a change in the interference pattern at each of the loop's detectors. Relative motion in a system can also produce Doppler shifts of the light beams that determine direction of motion. These changes and shifts can be used to maintain the relative positions of power system components, e.g., to sub-millimeter accuracies.

[0088] In another embodiment, multiple retro-reflectors and optical targets are placed on the circumference of the two concentrators and used for active and passive control. Laser transmitter/receivers and optical sensors are located on the power module, and the first fold mirror can monitor the position and orientation of these structures. The optical sensors can use stereoscopic images to measure precise orientation and approximate range.

[0089] Laser beams, such as modulated continuous wave (CW) laser beams, can be reflected from retro-reflectors. The phase of the returned beam can be compared to the phase of the transmitted beam. Pulsed laser beams can be reflected from the retro-reflectors and by measuring the time-of-flight, an independent range can be determined. Also a set of highly coherent CW laser beams can be reflected from retro-reflectors and interferometrically compared with the transmitted beams.

[0090] A change of one interference fringe can correspond to a change in range of one quarter wavelength of the laser emission line. Using homodyne detection, Doppler shifting of the beam can produce a beat frequency that is proportional to the rate of range change. Because of the extremely high frequency of the laser light, speeds of one millimeter per second can be measured. Thus, position and radial speed can be measured simultaneously with the proximity control system. Additionally, Charge Coupled Device (CCD) or stereo-

scopic cameras can be used to obtain spatial and angular measurements and range using stereoscopy of adjacent system components. These devices can also be used to navigate system elements into their initial (approximate) positions.

[0091] In an alternative embodiment, the proximity control system **13** uses a solar wind, primarily, and ion thrusters and electrostatic forces secondarily, to maintain the correct positions and orientations of the power system elements. The reflectors and fold mirrors can have paddle-like structures mounted on their circumference. The handle sections of the paddles point in the radial direction (with respect to the mirror) such that the paddles can be rotated with respect to the incident sunlight. By the proper rotation of the paddles, torques and forces can be imparted to the reflectors and fold mirrors. Ion engines can handle residuals that are not eliminated by the paddles. Furthermore, for free-floating elements that are not too distant, loose pseudo-tethers can provide limits and/or allow the use of repulsive-only forces to maintain positions if necessary. Thus, while embodiments of the invention eliminate or reduce connecting structures for aligning system components, they are also adaptable to other configurations, applications and supports. In another embodiment, the proximity control system **13** uses orbits, for example, about the Earth or other celestial body, so that the consumption of station-keeping fuel by the heaviest system elements is minimized. The other elements (e.g. fold mirrors of an optical or RF system) are positioned to maintain focus, alignment, boresight, etc. Since the latter elements are lighter, the station-keeping fuel required by the entire system is reduced. This configuration also provides greater flexibility in positioning reflectors with respect to the power module. Some components may be close enough that cables can tether them and repulsive electrostatic forces can be used to keep the cables taut.

[0092] Additionally, if necessary, the components can have distance or ranging sensors. For example, FIG. **1** illustrates distance sensors **2c**, **4c**, **5c**, **8c**, **10c** that detect the distance between system components. Various types and numbers of distance sensors can be utilized as needed. If a component falls outside an acceptable range or an orbit, one or more thrusters can be activated to re-position the component within the accepted range.

[0093] For example, a modulated laser diode rangefinder can be used to provide a continuous range to adjacent system components by comparing the modulation phase of transmitted and received range signals. As a further example, a pulsed laser rangefinder can provide a continuous range to adjacent system components by measuring the time-of-flight of transmitted and received signals.

[0094] FIGS. **5-17** illustrate alternative embodiments of a power system having free-floating elements and how sunlight is captured and processed to produce electric power. The control system sensors and thrusters shown in FIG. **1** are not shown in FIGS. **5-17**, however, the previously described components can also be used with the alternative embodiments. Further, the general manner in which the systems or components shown in FIGS. **5-17** is the same or similar to the system shown in FIG. **1**. Thus, all of the details regarding generating RF or optical energy with the alternative embodiments are not repeated. Components of alternative embodiments that are the same as or similar to the components shown in FIG. **1** are represented with like reference numbers.

[0095] Referring to FIG. **5**, in one embodiment, a space-based power system includes a lens system that includes

parabola and hyperbola shaped lenses, such as a Cassagrain optical system, inflatable mirrors, and membrane support elements. More specifically, the system includes a primary mirror **2**, a mirror **50**, membranes **50a-d**, such as transparent membranes, a first intermediate mirror **4**, a module that includes concentrators **6**, solar cells **7**, an RF or optical module **8**, RF transmitter feeds or optical emitters **9**, and a thermal panel **11** (as in FIG. 1), a second intermediate mirror **52**, and a reflector **10**.

[0096] The mirror **50** may be an ellipsoid-shaped mirror and is supported by four membranes **50a-d**. The mirrors **2** and **10** are supported by two membranes **50a-b**. The membranes are used to maintain the proper shape of the mirrors **2**, **10** and **50** using appropriate gas pressure. The mirrors are also supported by inflatable tubes or toroids (generally **24**). The inflatable toroids can be folded up prior to launch and inflated by gas or chemical air tanks once in orbit.

[0097] Sunlight rays **1** are reflected by the mirror **2** to a focus point **53**, from which they diverge and impinge on the mirror **50**. The mirror **50** relays the image via converging rays to the folding mirror **4**. The mirror **4** converges the rays to a magnified and even more blurred focus (e.g., now 0.34 km diameter), onto solar cell array surfaces **7** of the optical module **8**.

[0098] For example, in one embodiment, solar concentrator **6** paraboloids can be approximately 2.25 km in diameter, of focal length 4.125 km, and f-number of 1.8. Similarly paraboloids used for transmitting microwaves can have a diameter of 2.25 km, a focal length of 5.975 km, and f-number of 2.6. In both of these selected cases, the focal spot size of the sun at the first focus **53** of the primary mirror solar collectors would be about 36 meters.

[0099] DC electrical power generated by the solar cells **7** is converted into RF or optical power by the RF or optical power module **8**. The larger blur size of the generated energy beam is intended to match the dimensions of the surface of the array and provide quasi-equal illumination.

[0100] The energy emanating from the module **8** is directed to the fold mirror **52**. The fold mirror **52** is similar to a fold mirror **4** or **5** except that the mirror **5** is configured to reflect sunlight, whereas the mirror **52** is configured to reflect RF or optical energy. The fold mirror **52** directs the energy to the reflecting mirror **10**, e.g., having a parabolic shape. The energy arrives at parabolic surface of the mirror **10** via expanding rays and reflects the output beam **12** to the pre-determined location, e.g., Earth or a space station. As shown in FIG. 5, the beam **12** reflected by the mirror **10** in this system is a substantially parallel beam or a diffraction-limited beam.

[0101] FIG. 6 illustrates a further alternative embodiment that utilizes an optical system that is similar to the system shown in FIG. 5. In this embodiment, the mirrors are supported by two membranes, whereas the mirror **50** is supported by four membranes as shown FIG. 1.

[0102] Referring to FIG. 7, an alternative embodiment of a space-based power system includes an optical system, such as a Coude optical system, inflatable mirrors, and four-membrane secondary elements. The components are configured so that rays of sunlight arrive and fall collimated onto the solar cell array surface **7** of the optical module **8**. Further, the mirror **10** reflects the rays to a "spot" or a more focused point on the earth's surface compared to the systems shown in FIGS. 5 and 6.

[0103] FIG. 8 illustrates a further alternative embodiment. This embodiment utilizes a configuration that is similar to

that shown in FIG. 7, except that the system shown in FIG. 8 utilizes two membranes **50a,b** to support each mirror.

[0104] The embodiments shown in FIGS. 5-8 operate in a similar manner as the embodiment shown in FIG. 1A except that other embodiments use, for example, different membrane systems and optical components.

[0105] The previously described space power gathering, converting and transmitting systems are compound cooperative, in that the gathering and transmitting elements and the conversion module have a common axis of rotation. This arrangement allows various "horizontal" angles to be utilized, between the sending and receiving elements of each system, to point one element at the sun and one towards the earth during various seasonal orbital situations. Further rotation of one element's optical axis plane about the optical axis of other elements allows precision pointing of the "vertical" axis of the transmitter to various locations on the earth, while holding the collector positioned on the sun.

[0106] FIGS. 9-10 illustrate embodiments of a power generation subsystem. The wireless transmission subsystem components are not shown in FIGS. 9 and 10, however, various transmission subsystems can be utilized, including the previously described subsystems and the subsystems shown in FIGS. 12 and 13.

[0107] Embodiments of the generation subsystems of FIGS. 9 and 10 include inflatable mirrors, membranes, and multiple concentrators. In particular, the embodiments include a reflective mirror **2**, a pair of mirrors **50**, an intermediate mirror **4**, and a pair of modules having a concentrator **6**, solar cells **7**, an RF or optical module **8**, RF transmitter feeds or optical emitters **8**, and a thermal panel **11** (as in FIG. 1). Four support membranes **50a-d** support both of the mirrors **50** in the embodiment shown in FIG. 9, whereas two support membranes **50a,b** support the mirrors **50** in the embodiment shown in FIG. 10. In both embodiments, the mirror **2** includes two support membranes **50a,b**, one of the mirrors **50** is larger than the other mirror **50**, and one of the modules (**6, 7, 8, 9, 11**) is larger than the second module. DC electricity generated by the solar cells and output by the emitters **8** is processed as previously described.

[0108] Referring to FIG. 11, in another embodiment, a power generation subsystem can be configured without concentrators. Thus, the module **8**, emitter **9**, reflector **10** and panel components can be integrated together and connected via a power cable **10** and an electrical slip ring **112** or other suitable coupling to the solar cells **7**. When sunlight is incident upon the solar cells, the DC electricity generated by the solar cells is provided to the module (**8, 9, 10, 11**) via the cable **110**. The module converts the DC electricity into RF or optical power, and the emitters **9** provide the RF or optical power output to the phased-array antenna **19**.

[0109] FIGS. 12 and 13 illustrate embodiments of wireless transmission subsystems that transmit RF or optical energy generated by a power generation subsystem. Various generation subsystems can be utilized, including the previously described generation subsystems.

[0110] Referring to FIG. 12, one embodiment of a transmission subsystem utilizes a mirror **4** and a concentrator system that is orthogonal to the direction of the output beam **12**. Sunlight reflected from a mirror **4** is directed to an inflatable mirror **50** that is supported by two membranes **50a** and **50b**. The mirror **50** reflects the incident rays to a module having a concentrator **6**, solar cells **7**, module **8**, emitters **9** and panel **11**. The solar cells generate DC electricity, which is

converted to RF or optical power by the emitters 9. The output of the emitters 9 is directed to a reflector 10, such as an inflatable mirror, which is also supported by membranes and reflects the output beam 12.

[0111] The embodiment shown in FIG. 13 is configured for RF and utilizes a RF mirror element 130. More specifically, RF that is incident upon element 130 is reflected to a module having concentrators 6, solar cells 7, module 8, emitters 9 and panel 11. DC electricity generated by the solar cells 7 is converted by the module 8 into RF energy. The emitters 9 output the RF energy to the mirror 10, which reflects the output beam 12.

[0112] FIGS. 14-17 illustrate additional embodiments of space-based power system configurations. For example, FIG. 14 illustrates a configuration in which a single mirror 4 is configured to reflect sunlight 1 directly from the primary mirror 2 to the concentrators 6 and the solar cells 7, rather than reflecting sunlight indirectly to the concentrators utilizing a second intermediate mirror. The output of the emitters 9 is provided to the reflector 10, which reflects the output beam 12.

[0113] FIG. 15 illustrates a configuration that is similar to the configuration shown in FIG. 1, except that the module having components 6, 7, 8, 9 and 11 is placed between the first and second mirrors 4 and 52. Thus, the RF or optical beam output by the emitters 9 is reflected by the second mirror 52, which reflects the beam to the reflector 10, which generates the output beam 12.

[0114] FIG. 16 illustrates a configuration in which the generation and wireless subsystems each include two intermediate mirrors, such as fold mirrors. More specifically, the generation subsystem includes a primary mirror 2, and intermediate mirrors 4 and 5, such as fold mirrors. The sunlight is reflected from the second mirror 5 to the module having the solar cells 7 that generated DC electricity. The emitters convert the DC electricity into an RF or optical beam that is output to a mirror 52, which reflects the beam to a mirror 160. The mirror 160 reflects the beam to the mirror 10, which reflects the output beam 12.

[0115] FIG. 17 illustrates an embodiment in which the generation and wireless subsystems each include three intermediate or fold mirrors. More specifically, the generation subsystem includes intermediate mirrors 4, 5, and 170, and the transmission subsystem includes intermediate mirrors 52, 172 and 174. Incident sunlight 1 is reflected from the mirror 2, to mirror 4, to mirror 5, to mirror 170 to the solar cells 7. The cells generate DC electricity, and emitters 9 convert the DC electricity into an RF or optical beam that is output to a mirror 52, which reflects the beam to mirror 172, to mirror 174 and then to reflector mirror 10, which provides the output beam 12.

[0116] Having described various aspects and embodiments of a space-based power system, generation subsystems and transmission subsystems, persons of ordinary skill in the art will appreciate that the described and illustrated embodiments are advantages over known systems. For example, the connecting structures between system components are eliminated, thereby significantly reducing the weight of the system. Further, the free-floating system elements are aligned without using rigid connecting structural elements. Rather, these elements are free-flying and positioned and oriented using a proximity control system.

[0117] The space-based power system can also be applied to various power station sizes, configurations and locations.

For example, the space-based power system can be applied to a 1 GW power station situated in geostationary earth orbit (or any other orbit of need about any heavenly body of interest).

[0118] Additionally, since the elements of the illustrated embodiments are independent of each other (e.g. free-flying objects under the control of the proximity control system), the major structures (solar collector and the RF or optical transmission system) can be placed in orbits selected to minimize station-keeping fuel requirements of the system. The smaller fold-mirrors can be flown in other orbits, keeping the entire system in alignment and focus. Thus, the flexibility of the embodiments allows for reducing on-orbit fuel consumption.

[0119] Moreover, since the elements are free-flying, under the control of the proximity control system, failed elements can be moved out of position, and replacement elements can be moved into position. This flexibility simplifies the need for on-orbit module replacements and costly downtime. Failed system elements can also be placed in a parking orbit nearby so that, if in the future, repair or use for another mission is feasible, they will be readily available.

[0120] The space-based power system also enables the construction of large structures in space, specifically making the construction of a power station in geostationary earth orbit practicable, while overcoming shortcomings of prior systems that typically rely on heavy connecting structures. The elements of the system can also be precisely positioned, oriented and shaped without using large amounts of station-keeping fuel or structures.

[0121] The system provides an additional advantage of reducing photon pressure on the primary mirror 2 as a result of the selective reflection by the coating 2a. More specifically, the mechanical residual stress in the coating is set to counteract the solar photon pressure, and maintain an optically flat surface. The selective reflection may, reduce the solar photon pressure on the primary mirror by, for example almost 50%. To further reduce the heat load on the solar cells 7, the first fold mirror 4 can have the same coating as the primary mirror 2.

[0122] Further, by using large aperture optics, the need for a large solar array or a "farm" of many smaller collectors is no longer needed. Rather, a large reflector can collect and concentrate sunlight onto a much smaller solar array.

[0123] Persons of ordinary skill in the art will appreciate that various sizes, materials, shapes, and forms of optical elements can be used for other system configurations. Further, persons of ordinary skill in the art will appreciate that embodiments can use various frequencies including RF, infrared, and optical frequencies. The system components can also be assembled in different manners. For example, the components can be flown to space separately, in its own orbit. The pointing direction of the components can then be adjusted for alignment with other system components.

[0124] Additionally, the embodiments can be utilized in different locations and environments. For example, power can be provided to various space and terrestrial locations including, but not limited to, the earth, the moon, other planets, space stations, space vehicles, and satellites. Similarly, the proximity control system can control the position of power system components from various locations, e.g., from the Earth, the moon, other planets, space stations, space vehicles and satellites. The embodiments can also be configured with different numbers of mirrors, membranes, concentrators and other components. Further, different numbers of power elements of a system can be free floating. For example,

depending on a particular configuration or application, a few, most or all of the power system components can be free-floating or free of connectors.

[0125] Weather Management Using Space-Based Power System

[0126] Referring to FIG. 19, according to another embodiment, a space-based power system S can generate sufficient energy 12 and direct that energy 12 to a hurricane or other weather element 1800 in order to alter and weaken the weather element 1800. Thus, rather than beaming energy generated in space to a ground receive station for conversion into electricity, alternative embodiments focus space-born energy 12 and apply that energy 12 at specific location(s) and altitudes within a weather element 1800. FIG. 20 generally illustrates a space-based power systems that can be used with embodiments. The exemplary space-based power system S includes spaced-based power system embodiments described above and shown in FIGS. 1A-17. Persons skilled in the art will appreciate what other space-based power systems can also be utilized.

[0127] Referring to FIG. 21, according to one embodiment, a space-based power system (as shown in FIG. 20) tracks a weather element 1800 as it moves along a storm path 2100. The tracking beam 2110 is energy 12 generated by the space-based power system S and can be controlled to continuously track a particular section of a weather element 1800 or, alternatively, be applied at different times to specific regions as the weather element moves along the path 2100, to weaken or dissipate the hurricane 1800.

[0128] Energy 12 from a space-based power S system also can be applied to a weather element 1800 one time or multiple times and can be applied continuously, intermittently or periodically. The amount of energy 12 (e.g. time and/or magnitude) that is applied to a weather element 1800 can vary depending on, for example, the strength of the weather element 1800 and the energy 12 generated by the space-based power systems.

[0129] According to one embodiment, energy 12 from a space-based power system is RF energy 12 that is focused to a diameter of about 1 km to about 10 km, (e.g., about 5 km), and a frequency of about 2 Gigahertz (GW) to about 12 GHz (e.g., about 10 GHz), and a power of about 1 GW to about 2 GW (e.g. about 1.5 GW). One of the elements of the space-based power systems, such as a concentrator and/or a mirror, can be used to focus the energy 12 for application to the weather element 1800.

[0130] Focused RF energy 12 alters the weather element 1800, e.g., by inducing temperature changes and different airflows, which disrupt and reduce the strength of the weather element 1800. The RF energy 12 can also be used to steer the weather element 1800 in a different direction along a different path 2100.

[0131] According to one embodiment, a hurricane in its initial or formative stages can be identified, and RF energy 12 is applied to the weaker, preliminary storm before it matures and grows into a stronger storm. According to another embodiment, RF energy is applied to a portion of a mature storm in order to disrupt and weaken the mature storm.

[0132] Weather elements or storms that can be manipulated and disrupted by applying focused, space-born RF energy 12 include, but are not limited to, hurricanes, typhoons, tropical cyclones, thunderstorms, severe tropical cyclones, severe cyclonic storms and tropical cyclones and other weather elements and storms. This specification generally refers to a

“hurricane” and a “weather element,” and these two terms are defined to include all of the above-identified types of storms. Further, persons skilled in the art will appreciate that the hurricanes or weather elements can have different strengths, e.g., it is known to classify hurricanes as category 1, category 2, category 3, category 4 and category 5. Embodiments can be used to apply RF power to all of these types of hurricanes. Accordingly, embodiments can be used to disrupt storms having various labels, names and strengths.

[0133] For example, embodiments can be used so that focused RF energy 12 is applied to a hurricane or forming hurricane 1800 so that the intensity of the resulting hurricane is no greater than Category 1 when making landfall, thus preventing a stronger hurricane from forming. A Category 1 hurricane on the Saffir-Simpson Hurricane Scale is defined as having wind speeds of 74-95 mph (64-82 kt or 119-153 km/hr). The storm surge caused by a Category 1 hurricane is generally four to five feet above normal, and there is typically no real damage to building structures. Damage is primarily to unanchored mobile homes, shrubbery, and trees, and there may be some damage to poorly constructed signs and some coastal road flooding and minor pier damage.

[0134] Embodiments can also be used to reduce the strength of stronger hurricanes 1800, e.g., reducing a Category 4 or 5 hurricane to a Category 3 hurricane when the hurricane makes landfall. A Category 3 hurricane on the Saffir-Simpson Hurricane Scale is defined as having wind speeds of 111-130 mph (96-113 kt or 178-209 km/hr). The storm surge caused by a Category 3 hurricane is generally 9-12 ft above normal, and there is typically some structural damage to small residences and utility buildings with a minor amount of curtainwall failures. There is also usually damage to shrubbery and trees with foliage blown off trees and large trees blown down. Mobile homes and poorly constructed signs may be destroyed. Low-lying escape routes are cut by rising water three to five hours before arrival of the center of the hurricane. Flooding near the coast destroys smaller structures with larger structures damaged by battering from floating debris. For terrain continuously lower than five ft above mean sea level, there may be flooding inland eight miles (13 km) or more. Evacuation of low-lying residences within several blocks of the shoreline may be required. A Category 4 hurricane has wind speeds of 131 mph to 155 mph, and a Category 5 hurricane has wind speeds of greater than 155 mph. Following is a description of how hurricanes 1800 are formed, airflows that maintain a hurricane, and how embodiments can be used to disrupt these airflows to weaken and/or eliminate the hurricane.

[0135] More particularly, referring to FIGS. 22-24, tropical depressions that can lead to a hurricane primarily form in three ways. FIG. 22 illustrates a tropical depression that is formed by a group of thunderstorms that become organized into a coherent storm. FIG. 23 illustrates convergence of air from mid-latitude frontal boundaries to form a tropical depression. FIG. 24 illustrates easterly atmospheric waves from Western Africa converging to form thunderstorms to form a tropical depression. Embodiments can be used to apply energy 12 to these weather elements 1800 at the formative stages of a hurricane, thus reducing the amount of energy 12 that is needed to alter the hurricane 1800.

[0136] FIGS. 25 and 26 illustrate airflows in a typical hurricane 1800. Warm ocean water 2500 heats the air 2505 above it, and warm, moist air 2510 rises quickly, creating a center or eye 2515 of low pressure. Winds (trade winds) move towards

the low pressure and inward spiraling winds move upwardly. Rotation of the Earth causes the rising column to twist, thereby forming a cylinder-like shape that whirls around the center or eye **2515** of relatively still air. Cold air **2520** moves downwardly through the eye **2515**. Embodiments can be used to apply energy **12** to particular sections of a hurricane **1800** to reduce the strength of the hurricane when it makes landfall.

[0137] Referring to FIG. 27, according to one embodiment, energy **12** is RF energy (e.g., about a 1.5 GW of power) that is generated by a space-based power system S' and directed into a formative weather element that could grow into a stronger storm. In the illustrated embodiment, a group of thunderstorms **2701-2704** are in the process of organizing into a coherent storm. Focused RF energy **12** from a space-based power system S is applied adjacent to one or more or all of the thunderstorms **2701-2704** producing atmospheric temperature gradients. These gradients alter the paths of the thunderstorms. As a result, the thunderstorms **2701-2704** do not coalesce or converge together to form a more severe weather element. One manner in which RF energy can be used to create temperature gradients is shown in FIG. 28. The space-based power system S can significantly raise the air temperature over about a 5 km diameter of air near thunderstorm **2701-2704** or other weather elements **1800**. Heating areas of air using RF energy **12** from the space-based power system S causes air flows to change and prevents the storms **2701-2704** from converging.

[0138] Referring to FIG. 29, according to another embodiment, RF energy **12** generated by a space-based power system S is directed in the path of frontal systems **2901** and **2902**, e.g., mid-latitude frontal systems. As shown in FIG. 28, the RF beam **12** can significantly raise the air temperature over, for example, a 5 km diameter circle. The locations of heated areas of air are selected to alter the flow direction so that convergence of the fronts **2901** and **2902** can be significantly reduced, thereby preventing formation of a more severe weather element. In a further alternative embodiment, RF energy **12** from a space-based power system S can be applied to easterly atmospheric waves from Western Africa that are converging to form thunderstorms.

[0139] According to one embodiment, RF energy **12** generated by a space-based power system S is applied to the early stages of a Category 1 hurricane. Formation of a Category 1 hurricane can be detected using known weather satellites that provide data such as ocean surface temperature, wind velocity, precipitation rates, water vapor density, etc. This data can be analyzed or modeled to determine whether a Category 1 hurricane will form. For this purpose, referring to FIG. 30, the region **3000** between about 8 and 20 degrees north latitude in the Atlantic ocean can be monitored since hurricanes **1800** form most frequently in these areas. Further, the scope of monitoring can be determined based on water temperature. For example, areas having water that is at a temperature of about 79° F. (25° C.) or greater can be monitored.

[0140] Referring to FIGS. 25 and 31 in addition to being applied to formative stages of a hurricane, embodiments can also be applied to different categories of existing mature hurricanes in order to reduce the strength of the hurricane. Once a hurricane **1800** forms, even in its earliest stages, the eye **2515** is a region of descending cold air. If the air in the eye **2515** is heated by energy **12**, an inversion layer **3100** is formed. The inversion layer **3100** impedes or stops, downward flowing cold air **2520** through the eye **2515**. This, in turn, reduces the strength of the hurricane **1800** or, for the case

when the inversion layer **3100** results in of zero downward flow through the eye **2515**, completely dissipates the hurricane **1800**. In the illustrated embodiment, RF energy **12** is applied to a middle portion of the eye **2515**. Alternatively, the RF energy **12** can be applied to air at the top of the eye **2515** or at other locations. The amount of RF energy **12** that is applied to the eye **2515** can depend on various factors, such as the diameter of the eye **2515**, the temperature of the air at the eye **2515** and the size and strength of the hurricane **1800**.

[0141] An analysis of applying RF energy **12** at the top of the eye **2515** to create an inversion layer **3100** was performed. According to one embodiment, early detection by satellite sensors allows energy **12** from a space-based power system S to be applied to a hurricane **1800** having an eye **2515** with a diameter of about 7 km, compared to an eye **2515** of a full force hurricane, which can have a diameter of about 20-60 km. From NASA and NOAA observations, the downward speed of the descending air **2520** in a hurricane having about a 7 km eye **2515** is on the order of 6 cm/s. Thus, the volume flow rate (V_{dot}) can be calculated as follows: $V_{dot}=(3.5*10^3)^2*\pi*(6*10^{-2})=2.3*10^6$ m³/s From the NASA and NOAA temperature profiles of the eye **2515**, RF energy **12** should be applied to create an inversion **3100** at an altitude of about 100 mbar height (16,000 m) from sea level. At this altitude, the density of the air is about 0.17 kg/m³; and the mass flow rate (m_{dot}) can be calculated as follows: $m_{dot}=0.17 V_{dot}=3.9*10^5$ kg/s. At this pressure, air is nearly an ideal gas and is composed of diatomic molecules. Thus, the specific heat (C_p) of the air is: $C_p=7/2*R/m_w$, where R=Universal Gas Constant=8.314 J/(mol K) and m_w =molecular weight of air=28.966 g/mol or $C_p=3.5*8314/28.966$ J/(kg K)=1004.6 J/(kg K).

[0142] Thus, the power needed to raise the air temperature by 1K (1° C.) can be calculated as follows: $P=m_{dot}*C_p*\Delta T=3.9*10^5*10^3*1=3.9*10^8$ watts. Using space-based power system S embodiments, e.g., a system that generates about 1.5 GW of energy **12**, the energy **12** applied to the eye **2515** raises the temperature of the air at the top of the eye **2515** by about 4K (4° C.). Since the nominal temperature difference at an altitude of about 16,000 m is about 7° C., this 4° C. reduces the gradient to 3° C. and this rise in temperature slows the downward flow rate **2520** through the eye **2515** which, in turn, allows RF energy **12** to further increase the air temperature. Thus, under these conditions, the downward flow **2520** can be reduced or halted. The time required to achieve this effect can vary on a number of factors, but can occur over a period of hours.

[0143] According to another embodiment, the strength of a fully developed or mature hurricane **1800**, such as a category 4 or category 5 hurricane, can be reduced to a weaker hurricane, such as a category 2 or category 3 hurricane. One embodiment of reducing a category 5 hurricane to a category 2 or category 3 hurricane is discussed in further detail. A typical hurricane **1800** has an average power density of about 10⁸ watts per square kilometer. A space-based power system S can deposit approximately 10⁹ watts of energy **12** into one square kilometer in order to cause turbulence, which causes the storm to weaken or self-destruct. The temperature gradient that is generated can vary depending on the strength of the weather element **1800** and can be, for example, about 12° C. Further, energy **12** can be applied to different altitudes, e.g., at sea level to about 20,000 m to impact different sections and/or sizes of different types and strengths, weather elements **1800**.

[0144] For example, the eyewall **2600** (shown in FIG. 26) of a hurricane **1800** is maintained by a balance between the

centrifugal force between the cyclonic flow of the air in the eyewall **2600** and the low pressure of the eye **2515**. A RF beam **12** from a space-based power system **S** can be controlled so that it is focused just outboard (farthest from the eye **2515**) of the eyewall **2600** and to track that mass of air as it orbits about the eye **2515**. As a result, a localized low pressure region is formed on the outboard side, thereby destroying the balance between the centrifugal force between the cyclonic flow of the air and the low pressure of the eye **2515** in this region. Consequently, the eyewall **2600** in this region ruptures, and this disruption can grow due to the power of the storm, resulting in a significant reduction in the strength of the storm.

[0145] Another example is NASA satellite data indicates that the strength of a hurricane can be increased by "chimneys" of hot air that rise to 60,000 or more feet. A RF beam **12** from a space-based power system **S** can be controlled so that it is properly focused on the chimney and tracks it as it orbits about the eye **2515**. As a result, the chimney is destroyed; thereby, resulting in a significant reduction in the strength of the storm.

[0146] Referring to FIG. **32**, in a further alternative embodiment, one or more RF energy absorbing elements **3200** can be inserted into a hurricane **1800** in order to direct heat to a particular location of the hurricane. RF absorbing elements **3200** can be deposited into a hurricane **1800** using various known techniques, such as using a suitable hurricane aircraft **3210**.

[0147] More specifically on thermal, an RF absorbing element **3200** can be used to absorb RF energy **12** generated by the space-based power systems and convert it to heat and deposit that heat **3205** to a particular location of a hurricane **1800**. Absorbing elements **3200** may be useful in the event that RF energy **12** from a space-based power system **S** is not applied to a particular section of the storm with the desired accuracy. Further, energy absorbing elements **3200** can be used to obtain desired accuracy if obtaining the desired accuracy with the space-based power system would result in a system **S** that is more complex or costly than desired.

[0148] More specifically, an RF absorbing element **3200** collects RF energy **12** from the space-based power system **S** and converts the RF energy **12** into thermal energy **3205**, within the element **3200** and then deposited at the desired location in a weather element **1800**. In other words, the energy absorbing element **3200** provides a highly-absorbing and frequency selective surface and serves as an intermediate energy coupler or transmission element between the hurricane **1800** and the space-based power-system **S**, and accurately deposits heat energy **3205** to a desired location in the hurricane **1800**.

[0149] According to one embodiment, the energy absorbing element **3200** is a RF-absorbing chaff. The chaff can be fabricated from a material having a length that is about 50% of the RF energy **12** wavelength. Half-wave dipoles maximize electrical currents, which give the greatest ohmic (I^2R) losses. According to one embodiment, dimensions of a chaff **3200** for use with a 10-GHz RF beam **12** can be about 0.6" in length and about 0.01" in width. The chaff **3200** can have a thickness of about 0.001." Preferably, the surface area to mass ratio of the chaff **3200** is sufficiently large so that the chaff **3200** moves or floats within the air of the weather element **1800**. For example, the chaff **3200** can be maintained within a hurricane **1800** with nearly neutral buoyancy. Persons skilled in the art will appreciate that the size and shape of the RF

absorbing element or chaff **3200** can be selected to provide desired buoyancy in a hurricane **1800** and to provide the desired coupling of RF energy **12** to the hurricane **1800** as thermal energy **3205**.

[0150] The chaff **3200** material is selected to obtain desired ohmic (I^2R) losses and can be composed of or include various materials. In one embodiment, the chaff **3200** is aluminum oxide or another suitable RF absorbing material. In an alternative embodiment, the chaff **3200** is a plastic or other low density material that is coated with an RF absorbing material. In a further embodiment, the chaff **3200** includes a coating, such as iron oxide or another suitable RF absorbing material. Further, the chaff **3200** and/or coating materials can be designed so that they are uniform or non-uniform. For example, a surface of a chaff **3200** can include regions of different thicknesses, e.g., regular and thinned regions that vary periodically. The chaff **3200** or coating can include resistive material flakes for conversion of RF energy into heat **3205**. The chaff **3200** can be made of one material or combinations of materials, including combinations of the materials discussed above.

[0151] Persons skilled in the art will appreciate that the optimum heat absorbing element **3200** material and characteristics can depend upon the frequency of the RF energy **12**. Different types, numbers, shapes, sizes and weights of heat absorbing elements **3200** can be used to provide energy to a desired location within a hurricane **1800**. Accordingly, the above examples of materials, and coatings and dimensions are provided for purposes of illustration and explanation, not limitation.

[0152] Embodiments of the invention advantageously allow significant levels of RF energy to be inserted into a developing or mature hurricane or other weather elements to arrest its growth and possibly dissipate the hurricane. The benefits that can be realized with embodiments can be enormous, sparing substantial economic losses caused by residential commercial and infrastructure losses, and human losses associated with strong storms. A further benefit provided by embodiments is that the RF energy is generated from the sun, which is essentially available 24 hours a day, every day of the year. Heat absorbing elements or chaffs can also be used to apply energy generated by a space-based power system to particular locations of a storm. Certain insubstantial modifications, alterations, and substitutions can be made to the described embodiments without departing from the scope of the invention, as recited in the accompanying claims.

What is claimed is:

1. A space-based power system for altering weather, comprising:

a plurality of power system elements in space, the plurality of power system elements including at least one intermediate power system element in space that receives sunlight from one power system element in space and transmits the sunlight to another power system element in space; and a distributed control system that maintains alignment of one or more free-floating power system elements based on communications between control system elements of adjacent power system elements, the plurality of power system elements in space including a control system component of the distributed control system, wherein one or more of the elements of the plurality of power system elements are free-floating, and the plurality of power system elements are arranged to collect sunlight, generate electrical energy from the collected

- sunlight, and convert the electrical energy into RF energy that is applied to a weather element and to alter and weaken the weather element.
2. The system of claim 1, wherein a power system element focuses RF energy to a diameter of about 2 km to about 10 km.
 3. The system of claim 1, wherein about 10^9 watts/km² of RF energy is applied to the weather element.
 4. The system of claim 1, wherein the weather element is a hurricane.
 5. The system of claim 1, further comprising an energy absorbing element that is inserted into the weather element, absorbs RF energy generated by the space-based power system, and converts absorbed energy to thermal energy that is transferred to the weather element to alter and weaken the weather element.
 6. The system of claim 5, wherein the energy absorbing element is aluminum oxide.
 7. The system of claim 5, wherein the energy absorbing element is plastic.
 8. The system of claim 5, wherein the energy absorbing element has an iron oxide coating.
 9. The system of claim 5, wherein the energy absorbing element has a length of about 0.6", a width of about 0.01" and a thickness of about 0.001".
 10. The system of claim 5, wherein a length of the energy absorbing element is about 50% of the wavelength of the generated RF energy.
 11. The system of claim 5, wherein the weight per square centimeter of surface area of an energy absorbing element is sufficiently low so that the energy absorbing element is substantially buoyant with the weather element.
 12. The system of claim 5, wherein the energy absorbing element absorbs energy at a frequency of about 2 GHz to about 12 GHz.

* * * * *