

We've come up with another amazing piece of software which allows you to research keywords as well as to analyze the demand and supply of any niche market according to the keyword you enter with just a few clicks of the mouse. Enjoy the box.



# ***Phone 4 Energy***

## **Copyright ©2009 by Phone4Energy.com**

All rights reserved. No part of this digital book shall be reproduced, stored in a retrieval system, or transmitted by any means, electronic, mechanical, photocopying, recording, or otherwise, without written permission from the publisher.

No patent liability is assumed with respect to the use of the information contained herein. Although every precaution has been taken in the preparation of this digital book, the publisher assumes no responsibility for errors or omissions. Nor is any liability assumed for damages resulting from the use of the information contained herein.

## **Trademarks**

All terms mentioned in this digital book that are known to be trademarks or service marks have been appropriately capitalized.

The Publisher cannot attest to the accuracy of this information. Use of a term in this digital book should not be regarded as affecting the validity of any trademark or service mark.

## **Warning and Disclaimer**

Every effort has been made to make this digital book as complete and as accurate as possible, but no warranty or fitness is implied.

The information provided is on an “as is” basis. The author and the publisher shall have neither liability nor responsibility to any person or entity with respect to any loss or damages arising from the information contained in this digital book.

It is well known that some phone companies are against some or all of the techniques mentioned in this digital book. It is your own responsibility to confirm if your phone company frowns over these methods.

By reading this book you confirm that you had fully read and agreed to the Terms and Disclaimer found at:

[http://www.phone4energy.com/terms\\_disclaimer.php](http://www.phone4energy.com/terms_disclaimer.php)

# **Contents at a Glance**

|   |           |
|---|-----------|
| <i>Introduction.....</i>                              | <i>6</i>  |
| <i>Chapter 1 : Reducing Energy Consumption.....</i>   | <i>9</i>  |
| <i>Chapter 2: Energy Efficient Insulation.....</i>    | <i>22</i> |
| <i>Chapter 3: Weatherize Your Home.....</i>           | <i>33</i> |
| <i>Chapter 4: Energy Efficient Appliances.....</i>    | <i>40</i> |
| <i>Chapter 5: Reducing Wasted Energy.....</i>         | <i>50</i> |
| <i>Chapter 6: The Phone 4 Energy System.....</i>      | <i>62</i> |
| <i>Chapter 7: Building the System.....</i>            | <i>80</i> |
| <i>Chapter 8: Finding New Ways to Secure Oil.....</i> | <i>97</i> |

# ***Introduction***

## **Introduction**

We have the potential to produce all of our electricity from clean energy sources. Today, we have the technology and the know-how to move beyond our dependence on polluting power plants by using clean, safe, and free renewable energy. By harnessing the potential of zero point magnetic energy, we can transform how we produce electricity.

A clean energy future will rely not just on renewable energy, but also on better use of the energy we currently produce. By making the energy we produce last longer, or by increasing "energy efficiency," we can avoid the need for new polluting power plants. We can increase energy efficiency by using available technologies that do the same amount of work but use less energy, like a computer that goes to sleep when it's not in use.

Clean, renewable energy currently produces only about 2 percent of our electricity nationwide. In contrast, nearly 90 percent of our electricity still comes from polluting sources of energy like coal and nuclear power. Coal-burning power plants are the nation's largest

source of carbon dioxide, the heat-trapping pollutant that causes global warming. Coal-fired power plants are also responsible for pollution that increases asthma attacks and worsens environmental problems like acid rain, haze, smog, and other air and water pollution.

We can face these challenges by taking steps today towards a brighter energy future. Using existing technology and resources, we can cut our reliance on existing polluting power plants by providing at least 20 percent of our electricity from renewable sources of energy by 2020 and by increasing the energy efficiency of our appliances and homes. Zero point magnetic energy is a powerful source of clean energy, producing electricity with no global warming pollution and at zero cost.

# ***Reducing Energy Consumption***

**Chapter 1**

## **Reducing Energy Consumption**

Before even building our zero point magnetic power generator, you can start saving electricity straight away. Below you can find some of the most effective tips that you can implement in your home and save up to 50% or even more of your currently electricity bills - with simple steps that require little to no effort.

### **10 Ways to Reduce Your Energy Usage**

**1) Insulate and Ventilate** - Properly done, insulation can reduce home heating needs to almost 1/10 of an average residence. Savings are reaped in the summer as well. Use of air conditioners can be avoided or minimized in most regions. Weather stripping and caulking control air leaks, while air exchange keeps your indoor air fresh.

**2) High-efficiency appliances** - Energy Star appliances consume between two and 10 times less electricity. Initial costs can be up to 15 percent more, but it will come back in energy savings. Most are higher-quality products producing less noise and lasting longer.

**3) Fluorescent lighting** - Replace incandescent light bulbs with compact fluorescent bulbs (CFL). Although initially costing more, CFLs use four times less energy and last an average of eight times longer (about 8,000 hours). Fluorescent tubes last up to 20,000 hours and add further efficiency. Both can be used in dimmable fixtures for a longer lifespan and more comfortable house.

There are many diseases associated with allergic and stress disorders that are referred to as atopic dermatitis. Many of these diseases are associated with the respiratory system, such as hay fever and asthma for example.

**4) Reduce phantom power** - When not in use, appliances such as televisions, computers and microwaves are still consuming power. Wasted energy can total almost 25 percent of a home's electricity bill. Choose appliances with low standby energy consumption. A good range is 0.5 to 1 watt/hour or 4 to 8 kWh/year. A power bar can cut your losses if you switch it off when you're done on the computer. You can purchase individual switches to cut power when appliances aren't in use.

**5) Reduce home temperature** - Lower temperature by one or two degrees, and even more at night and while you're away to ensure no heat is wasted. Install a programmable thermostat to control the temperature for you.

**6) Use water efficiently** - A low-flow shower head can cut water consumption in half, which reflects greatly on hot water usage. Insulate electric water heaters and pipes, but not gas water heaters (start with the pipes at six inches away).

**7) Change furnace filters** - A clean filter will allow the furnace to operate more efficiently. Change it once a month when it's in use.

**8) Avoid batteries** - If using them is a must, choose less harmful rechargeable batteries. Then charge them with power from the sun.

**9) Buy locally** - The further a product has to travel before it gets to you, the more energy it has consumed along the way.

**10) Walk, bike, take the bus** - Anything that reduces the amount you drive lowers the amount of gas you use.

## **Lack of Energy Efficiency at Home**

Before you can make a big impact on the amount of unnecessary energy your home consumes, you have to find out which areas waste the most and what you have to trim down or shape up before you see a difference. An energy audit will point out trouble spots and provide you with the best places to start implementing solutions.



## Self Audit

You should know that most energy used in the home goes to appliances and lighting, then space heating, water heating and air conditioning. The most power-hungry appliance, your fridge, eats up almost 10 percent of energy consumed in the home. Now that you have a general idea of where to look, you can find ways to save. It's good to start with those little cracks and holes throughout your home that can add up to an area the size of a window. Imagine how wasteful you'd feel leaving a window open all year round. Many people are doing just that without even knowing.

You'll be checking for places where outside air can infiltrate the home, making sure you have adequate insulation and that equipment is properly maintained, and mapping out your energy usage patterns.

- ✚ Log it - If you want to know how much energy you use on average, you'll have to check the meter and do the math. It sounds tedious, but if you can remember to do it once a week for a month, you can get a good idea of your usual energy use that time of year.

🚧 Find leaks - Drafts can add up to 30 percent to your energy bill each year. Check around doors, windows, wall and ceiling corners, electrical outlets and switches, baseboards, pipes and wires. Often if an air leak is serious, you can feel the breeze with a wet hand or see daylight around the edges of doors. You may also be able to rattle windows and doors that aren't sealed correctly. The U.S. Department of Energy (DOE) website recommends a simple pressurization test that can help you detect less obvious leaks.

If you need more direction, the DOE links to a site offering online energy-auditing services that provide money-saving estimates based on answers you provide. Another page details how you can check insulation and HVAC systems. After that, you need to come up with a plan of attack: what areas can you afford to fix, and what should be done first? It's better to start with changes that put money back in your pocket sooner; some may save you enough to allow even more upgrades.

## **Hire a Professional**

Most utility companies will do a home energy audit, usually charging a small or no fee for customers. You can also hire a certified home energy rater. They'll go over past utility bills (that you provide them with), examine every room of the home, and use specialized equipment such as an infrared camera, surface thermometer, blower doors and furnace efficiency meters.

## **Find an ENERGY STAR Partner**

<http://www.phone4energy.com/energystar.php>

## Helping your HVAC System

We should all think of our homes as an energy system. So says the U.S. Department of Energy, which points out that although the furnace may create and deliver heat, it can't do so effectively if heat is lost in ducts, through walls, in the attic or through cracks in doors and windows. Even the most efficient furnace needs a little help and proper maintenance to provide the best results. Since heating and cooling often make up 45 percent of the energy bill, it's well worth it to tidy up operations.



## **Efficient Furnaces and Air Conditioners**

If you're in the market for a new heating or cooling system, it's the perfect time to go for high-efficiency. Your contractor should be able to point out the best models and help you find the right fit for your home. If you've already insulated and been busy sealing leaks and drafts in the home, you might even be able to get away with a smaller, cheaper furnace.

Furnaces have a minimum 78 percent AFUE (Annual Fuel Utilization Efficiency) rating, but some models are over 90 percent efficient. Air conditioners go by the SEER standard (Seasonal Energy Efficiency Ratio), and must meet a minimum of SEER 13.

When ventilation has been reduced through efficiency measures, it can become necessary to install air exchange units. Heat-recovery ventilators trade indoor air for out but keep the heat from leaving, too.

## Proper Maintenance

- ✚ Change furnace and air conditioning filters - Furnaces and air conditioners must work harder to pull air in through clogged filters, wasting energy to do it. If you clean or replace filters when it's recommended, you can lower energy usage by up to 5 percent. Once a month is the usual recommendation for replacing filters.
- ✚ Clean and vacuum registers, making sure nothing blocks them.

## Help the HVAC System Out

- ✚ In warm months, keep drapes closed during the day.
- ✚ In cold months, keep south-facing windows uncovered during the day and covered at night.
- ✚ Don't leave bathroom or kitchen exhaust fans on for more than 20 minutes after preparing food or showering. If they break down, replace with high-efficiency models (which will likely also be quieter).
- ✚ Insulate ducts in unheated areas, or if buying new ducts, choose ones that come pre-insulated. A professional should be hired for anything more than minor duct repair.
- ✚ Don't place heat-producing devices like lamps near air conditioning thermostats. It could make the system think your home is warmer than it is and overcool.
- ✚ Place window air conditioners in shade without blocking airflow.

## Programmable Thermostat

Keep your thermostat set at a comfortable level. During the heating season, 68 F should be good for daytime and 55 F at night or when you're out of the house. Central air conditioning doesn't need to be set lower than 78 F in the summer, unless health conditions require otherwise. A programmable thermostat can do all the altering for you, as long as you set it in advance. You can come home to a warm home, never knowing it was cold there during the day. Programmable thermostats often cost between \$40 and \$150, and can save you up to \$150 a year.



# ***Energy Efficient Insulation***

## **Chapter 2**



## Energy Efficient Insulation

Reducing energy use can mean a lot of things, but the most important on our list, insulation, is one that makes other measures possible. No matter how efficient your heating and cooling system is, it won't make a difference if your home's walls can't hold in the warmth. Heating and cooling can be responsible for up to 70 percent of a home's energy use. That's where insulation helps out in a big way.

Whether you want the best-rated insulation for a new home, or are looking to upgrade in an old home, energy-efficient insulation can come in many forms and vary in price widely. Adding insulation (including water heater insulation) can benefit homeowners in one of several ways:

- ✚ Lower utility bills - insulation often pays for itself in a few years; then it's all savings.
- ✚ Higher resale value of an efficient home with low bills.
- ✚ Increased comfort due to uniform temperature throughout the home. It will be warmer in winter and cooler in summer.

- ✚ Increased durability of the home - condensation, which can decay materials, is prevented.
- ✚ An energy audit can show how much insulation you have and how much more you need, but there are some places where insulation is a priority:
  - ✚ Attic, including the door or hatch cover
  - ✚ Under floors above unheated spaces
  - ✚ Around walls in heated basements
  - ✚ Exterior walls

## **Best Rated Insulation**

R-value is a measure of how well insulation resists heat transfer, meaning how much heat is let out of or into the home. Generally a higher R-value means better insulation, but since the rating is determined in controlled conditions, it may be lower in real-life applications, especially if insulation is installed incorrectly (air pockets are present or it is compressed). Metal-frame houses can cut R-value in half, but even wood framing will lower the rating. When layers of insulation are used, the R-value of each is added together. The R-

value you'll need depends on where insulation is being installed in the home. A professional can give you exact recommendations.

According to the U.S. Department of Energy, you should consider factors such as your climate, building design and budget when selecting insulation. They recommend a handy zip code calculator that lets you enter information about where you live and what you're insulating. It compiles weather and cost information by region and tells you what R-value will be most economical.

## **Insulation for your Health**

Of course, R-value has nothing to do with how health-friendly the insulation is. There are some insulation types that just aren't up to green home standards. But that's OK because there are also several healthy insulation alternatives that can provide comfort and leave you worry-free - as long as you balance out the efficiency measures with adequate ventilation.

## Non-Green and Questionable Insulation

Insulation with a high R-value is a good choice for padding your walls, but other factors like health considerations and product life cycle come into play for many who wish to upgrade their homes. Let's face it, some insulation is better than others.

### Types of Insulation

- ✚ Batt insulation is often made of mineral fiber (fiberglass or rock wool) and sold in blankets of various sizes and thicknesses. It can be the least expensive, but requires careful installation for effectiveness.
- ✚ Loose-fill insulation is loose fibers or pellets like fiberglass or cellulose (newsprint, cardboard or waste paper). It's blown into walls and the attic through a large hose. It's more costly than batt but can fill smaller spaces more easily and reduce air leakage.
- ✚ Spray insulation is a polymer like polyurethane that is injected or sprayed into walls, ceiling and floor cavities. It expands to fill the space and does double-duty as an air barrier, which can

make it competitively priced with some batt types. Spray insulation is commonly used for retrofitting.

✚ Rigid insulation can be large, formed sheets of fiberglass, polystyrene or polyurethane. It's often used in basements, crawl spaces and exterior walls.

## **Some problems with insulation**

Some foamed insulations, extruded polystyrene and spray polyurethane involve the use of HCFCs (hydrochlorofluorocarbons), which although not as damaging to the ozone layer as CFCs (chlorofluorocarbons), contribute to depletion nonetheless.

Expanded polystyrene doesn't use HCFCs or CFCs, but pentane used as a blowing agent can contribute to low-level smog formation if it's not captured. The ingredient styrene has been identified by the EPA as a possible human carcinogen.

In addition to these concerns, many synthetic insulations are sourced from non-renewable petrochemicals.

## **Fiberglass**

Formaldehyde used to bind fiberglass makes this insulation less than ideal for many because of concerns about off-gassing. The fear that fiberglass may cause cancer, respiratory diseases or allergies in the long term (like asbestos) has also been an issue although studies haven't proven a link. It does cause irritation with direct contact and high levels can aggravate asthma or bronchitis.

Some companies are now touting their green credentials and allaying fears about fiberglass being an unhealthy insulation. Owens Corning, maker of PINK fiberglass insulation, has been certified low-emission by independent, nonprofit organization GEI (Greenguard Environmental Institute). PINK is made from about 35 percent recycled content (bottles and jars) and is used in green building program Built Green Colorado.

## **Resources**

**<http://www.phone4energy.com/insulationguide.php>**

# Green Insulation

There are a number of insulation manufacturers who strive to make their products low-emission, low-impact and highly efficient. From reused denim to futuristic spray-foams, there are a lot of products to consider, and others to be wary of.

## Cementitious

Air Krete - This nontoxic, environmentally friendly insulation is fireproof and sound-absorbing, as well as being very low in volatile organic compounds (VOCs). Air, seawater and formaldehyde-free cement make up Air Krete's blown-in insulation, which goes on like shaving cream and hardens into a lightweight foam. It doesn't require treatment with chemicals for its non-combustible performance, like some other insulations do, but there have been concerns about shrinkage over time.

## **Spray**

Icynene - This blown-in soft foam insulation also works as an air barrier, potentially stopping more than 90 percent of air infiltration and minimizing allergens and pollution that enter the home. It is installed in closed or open cavities by pouring or spraying and can expand up to 100 times its initial volume. Since it's water-blown, it doesn't have any ozone-depleting HCFCs. Icynene is also free of formaldehyde. R-values of the products range from 3.6 to 4 per inch.

## **Soy-based polyurethane**

Heatlok Soya - Aside from the fact this insulation is literally green in color, it's also pretty green in composition. Recycled plastics, vegetable oil and soy make up this spray polyurethane foam, which contains no ozone-depleting substances and works as an air and vapor barrier.

BioBased Insulation - These soy-based polyurethane spray foams create an air barrier to outdoor pollution by filling every space, which also cuts down on noise. Soybean oil is used to make them instead of

petrochemicals, and they don't allow mold growth or serve as a food source for pests. No CFCs or VOCs are present in BioBased Insulation products and they will never settle. Their products have been recognized by many organizations in lists of innovative or top products.

## **Cotton**

Bonded Logic - UltraTouch Natural Cotton Fiber insulation uses 85 percent post-industrial cotton, meaning denim manufacturing scraps that didn't get to fulfill their destiny and become jeans. It's treated with a natural fire retardant that also inhibits pests and mildew, and it's 100 percent recyclable. No VOCs like formaldehyde are present in this insulation. It's also easy to handle (not itchy) and sound-absorbing once installed, with a 4.1 per inch R-value. UltraTouch has tested well, receiving a Class A fire rating, and can earn users LEED credits.

These are by no means the only green insulation alternatives, but to go through them all could take a while. Others that have been

received well include cellulose-, wool- and hemp-based insulations, to name a few.

# ***Weatherize Your Home***

## **Chapter 3**



# **Weatherize Your Home**

## **Caulk, Strip and Sheet**

After finding air leaks and drafts in your home, you'll want to plug them up and stop money from slowly draining out of your walls, windows and doors. The fixes can be costly and long-term, requiring professional assistance, or cheap and easy to do yourself.

Most say that adding caulking and weather stripping will pay for itself within one year through energy savings. Just make sure, before you seal leaks, that the air in the home is properly ventilated. Dust, carbon dioxide, mold and other contaminants can cause a big problem if they are allowed to build up in the home.

## **Plastic sheeting**

If you can't afford to replace old drafty windows, which is really the best thing to do, make a quick fix by installing plastic sheeting. Just because you still have single-pane windows doesn't mean you can't cut energy lost through them. Heavy-duty plastic sheets are clear and can be cut to almost any size. Simply apply tape along the edges of

the window frame, stick the plastic down, and apply heat to make a tight seal. Then you just have to remember to close shades at night and all the time on north-facing windows.

## Weather Stripping

Metal, vinyl, rubber, foam or felt are all materials that can make up weather stripping. The type you use will depend on where it is going to be used, so it's safe to say you'll need several kinds:

- ✚ Felt and open-cell foams - They are cheap and easy to install, which is why they can be a good choice in low-traffic areas. For other uses, however, they are easily visible, can be affected by weather and don't do very well at blocking airflow.
- ✚ Vinyl - It costs a bit more than felt, but resists moisture and generally lasts longer.
- ✚ Metals - Stainless steel, aluminum, bronze and copper weather stripping can be affordable and last for a number of years. Older homes might do better with the look of metal as opposed to vinyl.

## Caulking

Caulking is relatively inexpensive and requires little expertise to use. Simply use it to cover cracks and holes around windows and door frames, baseboards or anywhere else there's a problem. As long as a crack is no more than  $\frac{1}{4}$  inch wide, caulking should fix the problem. Some caulking must be used in a gun, while other types don't require one at all. The DOE website provides a list of common caulking compounds and what uses they are best for. Water-based is the best for cleanup and is more environmentally friendly all-round than solvent-based caulk. Look for one that doesn't contain formaldehyde, like AFM Safecoat. It's also flexible and water-resistant once cured, so it can be used for a variety of applications. In general, one tube of caulking is enough for 25 feet of product if applied  $\frac{1}{4}$  inch wide.



# Energy Efficient Windows



## The right kind for any climate

When plastic sheets, caulking and weather stripping just aren't helping the home efficiency situation enough, replacing windows might be the only option. Single-pane windows, which are still in use in many U.S. homes, are pretty much the worst in terms of energy loss. Double-pane energy-efficient windows have special glass that can make a big difference.

The cost of installing new windows won't be paid off for several years through energy savings, but it can have a big impact right away in

terms of comfort and function. National Fenestration Council labels let you know the window is certified to perform as claimed, and Energy Star labels mean it offers a higher level of energy efficiency. Look for windows rated at less than 0.3 cubic feet per minute of air leakage.

Homes in the Sunbelt - Double-glazed windows with spectrally selective coatings can cut your need for home cooling by up to 15 percent by reducing the amount of heat that's let into the home. They literally reflect some of the sunlight away. Other methods to keep the home cool include installing awnings on windows that face south or west, or covering windows with sun-reflecting film.

Homes in cold climates - Windows coated with low emissive (low-e) substances and filled with gas can prevent heat from escaping the home by reflecting it back into the room. Look for windows with a U-value below 0.35, which means they are better insulators.

Homes with both needs - These windows need to have both low U-values and low solar heat gain coefficient (SHGC) ratings, to get the best of both worlds. You might have to decide which is more

important for your situation, free solar heating in the winter or keeping the hot sun out in the summer.

If you are building a new home or plan to upgrade your furnace within a few years, choosing the right windows can allow you to get a smaller, less costly HVAC system.

A somewhat cheaper solution, that's more long-term than most weatherizing methods, is installing storm windows. Whether exterior or interior, they can reduce heat loss by 25 to 50 percent, even more if they are low-e coated.

Curtains and shades can still be effective for energy-efficient windows if used correctly. In warm months, keep south-facing windows covered during the day. In cool months, allow the sun to come in through south windows during the day but cover them at night.

# ***Energy Efficient Appliances***

## **Chapter 4**



# Energy Efficient Appliances



## Saving power and your money

Most people spend almost \$2000 each year to power their homes.

Choosing to buy appliances that are low on power consumption, such as those labeled Energy Star, can save you money. Not only that, you'll be reducing your footprint and helping to protect the environment. Switching to CFL light bulbs is a good start, but big energy savings can come with larger power-consuming appliances.

## But doesn't it cost more?

The price tag of an energy-efficient appliance can initially be more than others. But the price in the store doesn't compare to the money you'll be saving while it's plugged into your outlets. If you're a really good shopper and have some time to compare, you might be able to

find an energy-efficient version that actually costs less than a standard appliance. Shopping online can be a great way to find better deals than in stores.

If you need to replace an old or broken-down appliance, going more efficient, even if it's a bit more expensive, will end up saving you money. You'll probably make up the difference in a few months to a year, and the rest will be savings. Some products, purchased in certain areas, can get you a rebate to further make up the price difference.

## **Why energy-efficient appliances are good**

Not only are they good for your pocketbook, efficient appliances are good for the environment. According to the government's Energy Star website (it's a joint program of the U.S. Environmental Protection Agency and Department of Energy), one in ten homes using energy-efficient appliances would equal the planting of 1.7 million acres of trees.

## Eligible Energy Star Appliances

- ✚ Refrigerators
- ✚ Freezers
- ✚ Dishwashers
- ✚ Clothes washers
- ✚ Air conditioners (room)
- ✚ Air cleaners (room)
- ✚ Dehumidifiers
- ✚ Water coolers
- ✚ Battery charging systems (for cordless phones, appliances, electric shavers ...)

[Design note: can you put this factoid in a box? Cost per year = kWh  
(700) x utility rates (8.4) = total costs for 1 year (\$58.80)]

## The EnergyGuide label

The EnergyGuide label lists yearly average running costs and will likely display whether a product is Energy Star qualified. It also compares energy use to similar products using a bar scale with an arrow showing where the appliance sits.

Energy-efficient appliances will have lower kWh/year. If you can find that number for a current appliance, you'll be able to figure out the cost difference between old and new. Power use isn't the only efficiency measure though; some appliances will have their own factors for other savings, such as clothes washers and water usage.

# Energy Efficient Light Bulbs



## **CFL bulbs make sense and save cents**

Compact fluorescent light bulbs, or CFLs as the often spiral-shaped bulbs are known, can work just as well as any incandescent bulb, while using less energy, lasting longer and providing increased safety. If you want to ease yourself into fluorescent lighting - because it does cost more initially - replace the most often-used bulbs. Those are usually the kitchen, living room, bathroom and outdoor porch lights.

## CFLs Save money

According to the government's Energy Star website, changing just five lights to efficient bulbs like CFLs would save \$60 a year in energy costs. But you don't have to stop there. Although CFLs cost more, it's easy to find them on sale and they are often cheaper in large quantities. Buy enough to fit most of the fixtures in your home, even if you don't need to replace the bulbs yet. When current bulbs burn out, the new CFLs are already on hand. Almost an entire home can be lit by compact fluorescent light bulbs, meaning frequent light bulb changes will be a thing of the past and power consumption will be cut drastically.

## Some CFL facts

- ✚ Last up to 10 times longer than incandescent
- ✚ Use about 2/3 less energy
- ✚ Generate only 30 percent the heat, meaning safer operation  
(and less heat added to the home)
- ✚ Different types can fit most regular fixtures
- ✚ Can work indoors or out

To be qualified as Energy Star, the gold standard in energy efficiency, CFLs must give off the same amount of light as regular bulbs, turn on instantly, make no noise and provide light in the warm color range.

If you have a specific fixture in mind for a CFL, like one attached to a dimmer switch, make sure to choose a bulb that is specified for that use. It's a good idea to read directions for any bulb you haven't used before to ensure you're not placing it in the wrong type of fixture.

Although most CFLs are warm tones, you can purchase cool-tone bulbs for focused task lighting.

[Design note: please put this in a box. Buy CFLs with lumen outputs consistent with those of incandescent bulbs. Forty watt incandescent bulbs put out 450 lumens, 60 watt bulbs put out 800 lumens and 100 watt bulbs put out 1,600 lumens.]

Some think LED (light emitting diode) light bulbs are the future because they'll provide even more lighting power and less energy consumption than CFLs, as well as lasting longer. But until LEDs become more affordable and readily available, CFLs are still the best

bet for saving money and energy. Now if you could just get rid of that phantom power that's being drained from your home when you least expect it.

# ***Reducing Wasted Energy***

**Chapter 5**

# Reducing Wasted Energy



## Reduce Phantom Power

Some people give it the more ominous name of “vampire load” and some tame it down with “idle current.” But however you refer to it, standby, sleep or phantom power is still just wasted energy.

If your microwave oven displays the time when it's not nuking TV dinners, it's all thanks to electricity. It takes power to display the time -

on some machines even more power than it takes to actually heat food. That's because while you only use the microwave for cooking about one percent of the time (power consumption during cooking is 100 times higher), the other 99 percent of the time the clock is the only thing running.

It has been estimated that about 10 percent of total home energy use is due to appliances and electronic equipment in standby mode.

## **Find phantom power and Kill-A-Watt**

This handy little device, and others like it, can be plugged in between an appliance and the wall, detecting just how much energy that appliance takes while in use or just waiting to be used. They usually cost about \$20 to \$40, well worth it to find out where you're unwittingly wasting energy in the home.

## **What could possibly be using that much energy?**

Aside from the glaringly obvious microwave clock, power is also being consumed by televisions, stereo equipment, DVD players and

computers. Even a small amount of standby power consumption can be a problem when it's added to other appliances that are also consuming phantom power.

## **Why does the equipment need to be in standby?**

The reason you can turn the TV on with a remote is that it was never fully turned off to begin with. If it was, the remote wouldn't be able to turn it back on. The television usually sits silently, screen off, while it saves information about the channel you were on and the volume level. If you've ever noticed the channel changes to a preset station when the power goes out, it's because the television's access to power was cut off.

Other power-drawing electronics include electric toothbrush charging stations, cell phone chargers and AC adaptors (wall warts). Many people don't realize it, but a charging device left plugged in continues to draw power even if it has nothing to recharge. The best way to solve this problem is to unplug anything that's not in use.

## **Solving the phantom power problem**

For some areas, like computer stations or entertainment centers, unplugging is likely too difficult to be an option. That's where power strips come in. If you plug everything into an easily accessible power bar, all you have to do is flick a switch to cut the power. What's more, you'll be protected from power surges that can damage equipment. Now if you could just find appliances that don't waste energy while they're turned on.

# Save Water Save Energy



## **Increase efficiency and use it effectively**

It's likely that over 10 percent of your utility bill is allocated to heating water. Whether it's for showering, washing dishes and laundry, or simply just to keep it in constant availability, it takes a lot of energy to provide the luxury (or necessity depending on how you look at it) of hot water.

## **Insulation, it's not just for your walls**

Most people know the key to energy efficiency in the home is to prevent heat from escaping through walls by adding insulation. But

there's another place heat is lost - from your water heater. Like phantom power in electronics, there is standby loss in water heaters. Much of the time the water heater is using energy to maintain peak temperature, even when no water is being used.

Fitting the water heater with a thermal jacket (if the manufacturer doesn't caution against it) can help prevent unnecessary heat loss. The hot water pipes running from the heater to taps can also be insulated. When it comes time to replace the water heater, you can go with a high efficiency model, such as the increasingly popular tankless water heaters.

## **Stop overheating your water**

The water heater only needs to be set to 120 F, but many people have set theirs to 140 F or even 160 F. If you're unsure, try it out for a few days. You'll probably find you don't notice much of a difference, and if you do you can always turn it up a bit at a time until it works for you.

## Water savings in the bathroom

According to the EPA (Environmental Protection Agency), showers are responsible for 20 percent of indoor water use.

- ✚ Low-flow shower heads - Faucet aerators, which are great for reducing water use in all areas of the home, can make a big difference in the shower. They decrease the amount of water that comes from the tap, while forcing air into the stream to make up for it. You won't even notice a difference, but it can save you over 5 percent of the water you normally use, and all the heating costs associated.
- ✚ Showers instead of baths - Quick showers use a lot less water than bathing. But if you absolutely can't give them up, don't fill the tub completely; about 1/3 should do.

Other ways to conserve water and energy are washing laundry in cold cycles, running only full loads in the dishwasher and making sure to replace old equipment with energy efficient appliances.

# Better Rechargeable Batteries



## Recharge with alternative energy

Disposable batteries - Whether lithium or alkaline, disposable batteries aren't a good choice in terms of waste. They work well in high energy-drawing applications, but once drained they're useless. Rechargeable batteries will cost more up front, but you'll quickly realize savings by not having to buy more disposables. Alkaline batteries put out 1.5 volts initially, but this drops steadily during use, eventually to below one volt.

**NiCd** - Nickel Cadmium (a toxic heavy metal) batteries, although among the cheapest, are considered to have more negative

environmental impacts than most other types. NiCds have problems with damage due to overcharging and improper storage. If they aren't fully discharged before recharging, their capacity becomes reduced. It can be fixed but is somewhat of a hassle. If you have NiCd batteries that don't hold a charge anymore, make sure to recycle them and choose a different type next time around.

## **Better Batteries**

**NiMH** - Nickel metal hydride batteries are a good way to reduce your energy use in the home. They can be substituted for alkaline batteries in many applications and are great for wireless keyboards, phone headsets, tape recorders, radios, pagers, cameras, walkie talkies, remote controls and digital cameras.

- ✚ 1 to 5 percent of the charge is lost daily when not in use  
(depends on conditions)
- ✚ 1.2 volts produced until steep decline at end of charge
- ✚ Should occasionally be completely discharged to maintain capacity
- ✚ Store more energy than NiCd but for a shorter period of time

- ✚ Up to 1000 charges depending on the brand
- ✚ Perform well in temperature extremes, but not below freezing

Despite common misconceptions, short charges won't damage these batteries. The biggest problem is with overcharging, but most chargers are made to shut off when the batteries are full. Look for smart chargers that not only stop charging when full, but can be used for storage by trickle charging to maintain the battery's charge.

**Li-ion** - Lithium ion batteries are more powerful in many ways but are only used in specialized contexts.

- ✚ Used in cell phones and laptop computers
- ✚ More expensive due to complex manufacturing
- ✚ Don't come in standard AAA, AA, C or D sizes. Might be a good thing though, because in the wrong charger they could ignite (alkalines will only burst).
- ✚ Must be recycled. Many places that sell them will recycle them as well.
- ✚ Store more energy for the same size

- ⚡ Operate at 3.7 volts meaning one cell can be used in place of multiples of other types
- ⚡ Can hold a charge for months without losing much power
- ⚡ Should be stored fully or partially charged. If it loses too much charge, a safety mechanism won't allow it to be recharged.
- ⚡ Must only be used with intended charger

## **Emergency preparedness batteries**

It's a good idea to have some back-up power in case of an outage.

Instead of a gas-powered generator, think about having a big rechargeable battery on hand. They can be used to jump-start your car, inflate tires, run emergency lights or radios, power your fridge or appliances, or just run home electronics when you're away from an electricity source.

## **Solar chargers**

There are a variety of solar chargers that can accommodate your rechargeable batteries without grid hookup. They are good to have on trips, in case of emergency, or just to avoid using non-renewable

energy. Depending on the type you buy, you'll be paying around \$60 to several hundred dollars. They can come as basic solar panels and hookups, or be integrated into bags or backpacks. Look for a solar charger that will work with the batteries or devices you want to recharge. With many, you'll have to buy a battery charger dock that attaches to the separately purchased solar charger.

# ***The Phone 4 Energy System***

**Chapter 6**

# The Phone 4 Energy System

The Phone 4 Energy System can be connected to your electricity system in a variety of ways. Below you can find some diagrams of the most commonly used setups. Note that the below setups can be used for different power sources, including wind, solar and other sources of energy.

## Simple Power Setup

You can create your own system without breaking the bank, usually under \$20. We discuss how to properly construct the system in a later chapter.

Keep in mind, batteries always work better in a warm temperature so you might consider buying a battery box. The battery box is great for storage, it keeps things clean and organized; it also keeps children or pets from playing around and getting hurt.

You might consider adding a system meter to act as a go between your battery and inverter. A system meter tells you how much juice the battery has left and how much power is being used at any given time.



**1. Phone 4 Energy System**

**2. Charge Controller**

**3. Battery**

**4. Inverter**

**5. Household**

## Grid-Intertied Power Source System

If you are still using power from the grid, this kind of system will work the best for you. This system can also be called on-grid-tied. You can actually make the electric meter tick backwards, by producing more power than you use each day. You can actually get a credit from the electric company if the meter starts going backward. Save those credits when the phone 4 energy system is off or when more electricity will be needed. This process is known as net metering or net billing. Of course, it's always a good idea to talk to your electric company to find out the rules and regulations.

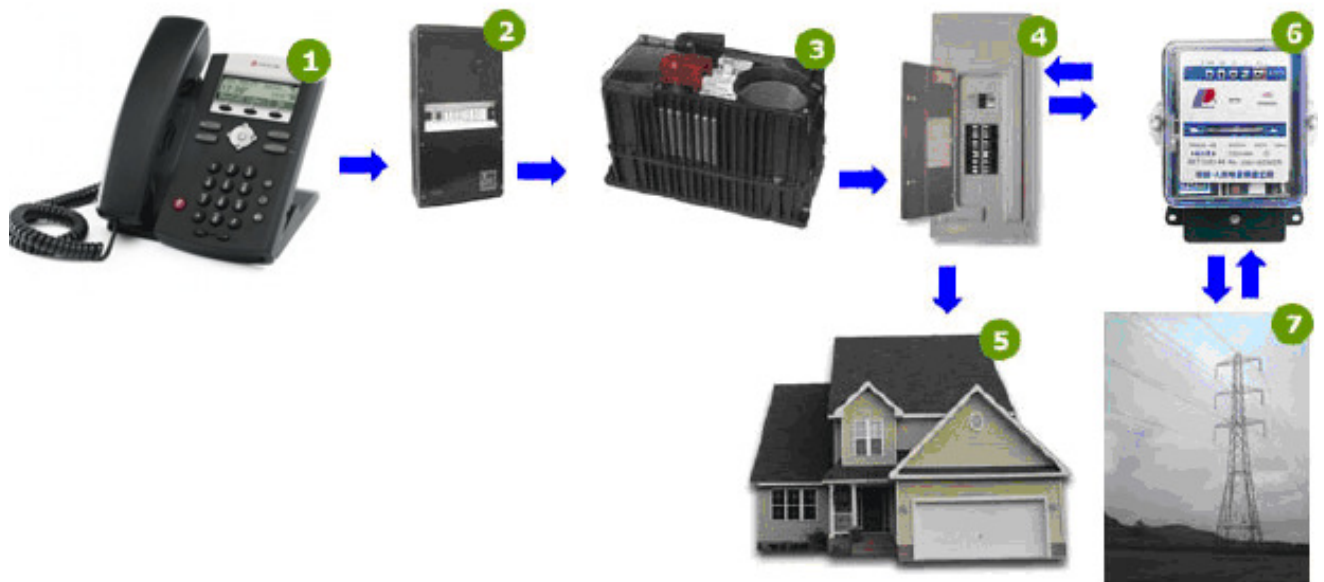

**1. Phone 4 Energy System**

**2. Array DC Disconnect**

**3. Inverter**

**4. AC Breaker panel**

**5. Household**

**6. Kilowatt per hour meter**

**7. Grid**

## Grid-Intertied system with battery backup

You may need to rely on a battery backup system in case of down time and maintenance to the power system. The picture below shows the grid inter-tied system with the battery backup.



1. Phone 4 Energy System

2. Array DC disconnect

3. Charge Controller

4. Deep cycle battery

- 5. System meter**
- 6. Main DC disconnect**
- 7. Inverter**
- 8. AC Breaker panel**
- 9. Kilowatt per hour meter**
- 10. Grid**
- 11. Household**

## Off-Grid Power Source System

This system requires a generator to keep the battery charged for those down times. This system is pictured below.



1. Phone 4 Energy System
2. Array DC disconnect
3. Charge Controller
4. Deep cycle battery
5. System meter

**6. Main DC disconnect**

**7. Inverter**

**8. Generator**

**9. AC Breaker panel**

**10. Household loads**

## System Units

### Array DC Disconnect:



The DC disconnect is an important part of a system for maintenance. Using a DC disconnect makes shutting off the power much easier.

### Charge Controller



A charge controller will drastically increase the life of your battery. This unit will protect the battery from being overcharged. When the battery bank is fully charged, the charge controller will interrupt the charging process. Some charge controllers also stop the battery from discharging at night time.

## 4v to 12 v Deep Cycle Battery



This is the type of battery you should use in your system. This is what will store all of the energy produced by your PV panels. A great place to source free deep cycle batteries from is old golf carts or forklifts.

## System Meter



A system meter is used to monitor how full your battery bank is. You can also see how much power is being used at any time. This is a great unit that can monitor your whole solar electric system.

### **Main DC Disconnect:**



This unit is placed between the battery bank and the inverter. A main DC disconnect will allow you to disconnect the inverter for maintenance.

### **Inverter:**



The inverter is what turns the direct current (DC) into alternating current (AC). AC is what most of your household appliances use. Eg. Refrigerator, TV, VCR, Computer etc. If you do not wish to use any appliances that need AC

then you can simply use a DC input. A DC input costs around \$10 from any car parts store.

You can also purchase inverters that plug into your homes power socket. These inverters will actually feed electricity back into your home through a normal power socket.

**Generator:**



If you are setting up a solar electric system for off-grid living you will need to use a generator. A generator is used to produce electricity for times of cloudy weather or for when you are performing maintenance on the solar electric system.

### **AC breaker panel:**



This is the point where all of the homes electrical wiring meets with the provider of the electricity, whether it is the grid, a solar electric system or a wind electric system. This unit is usually found in a utility room a garage or mounted in a metal box on the outside of the building.

### **Grid:**



The grid is the main power supply coming to your house.

## **Household Load:**



The household loads consist of anything in your home that uses power from your AC breaker panel. This includes anything that you plug into the wall.

## **Multi Meter**

You will be using the multi-meter to measure the input amps and voltages of the batteries. Although it is okay to use a digital multi-meter, it is recommended to try and use an Analog. The reason for this is you are using a pulse DC in the SSG and an analog will go up to 1amp or more.



## Soldering Iron

You will use the soldering iron for soldering the circuit. The circuit will work properly without soldering the connections, but it is still a good idea to hold them firmly in place. Once you are certain all the wiring is correct, solder all the connections at one time so nothing accidentally moves.



# ***Building the System***

**Chapter 7**

## Building the System

There are numerous ways to generate free electricity and we have found a simple way to produce electricity directly from a phone line. There are different ways to do this and each one of them will produce a different amount of electricity.

The best time to use these methods is at night because your phone isn't busy at this time. The following is a basic way of producing electricity. When you will use this method at night, or even during the day, any incoming telephone call activates the capacitors which will then charge faster giving more input amperage. The drawback with this method is that the phone will not ring. There is a way to overcome this problem using a ceramic permanent magnet capacitor block filter but it will incur a slight loss in amperage. This method is shown in the diagram on the following pages.

We have researched and tested several ways to gain the maximum possible voltage and amperage from a phone line, and will explain these later. If you have a better way please contact us; we welcome your suggestions.

## Objective

These methods allow you to have a free energy supply in your home. There are many people who can't afford to pay their bills but they do have a phone line. This way of generating electricity is fast and inexpensive once it is set up. Most people with phones are not aware of what can they do with their phone lines and they don't realize that there is a 50 v dc current running in their phone line, or that when a phone rings it gives 3 times more amperage to the charging system. Until your battery is fully charged, set up the phone so that rings every so often for about hour. The phone company won't charge you extra!

Remember car batteries will not work for this purpose. You must use 4v to 12v deep cycle marine batteries connected in parallel to increase your amperage hour, and then connect the inverter to your fully charged battery bank to access the free electricity! Always keep your battery at least 25% charged and the battery will last for years. If it goes under 25%, or if you overcharge it, the battery life will be less. To check this you can use a digital volt meter. You can also use a DC volt meter to find the negative and the positive terminals.

Note that if you do not ground the positive terminal to the earth it can kill your phone line for approximately an hour.

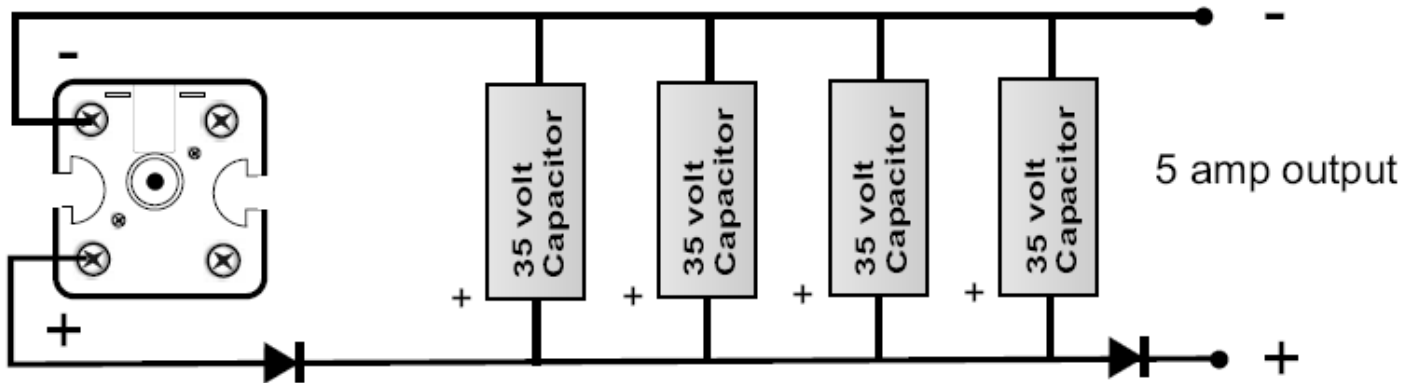

Using the diode, this can also be used as a battery charger. Use 4 - 35 v uf electrolytic capacitors. If you have 2 phone lines, use them both to get 100 vdc and gain double amperage output. Use 4 – 150v x 4700 uf capacitors and you can then pulse the 100v into a 15k volt neon transformer to get 14000 vac output to power various neon bulb tubes, or fluorescent bulbs.

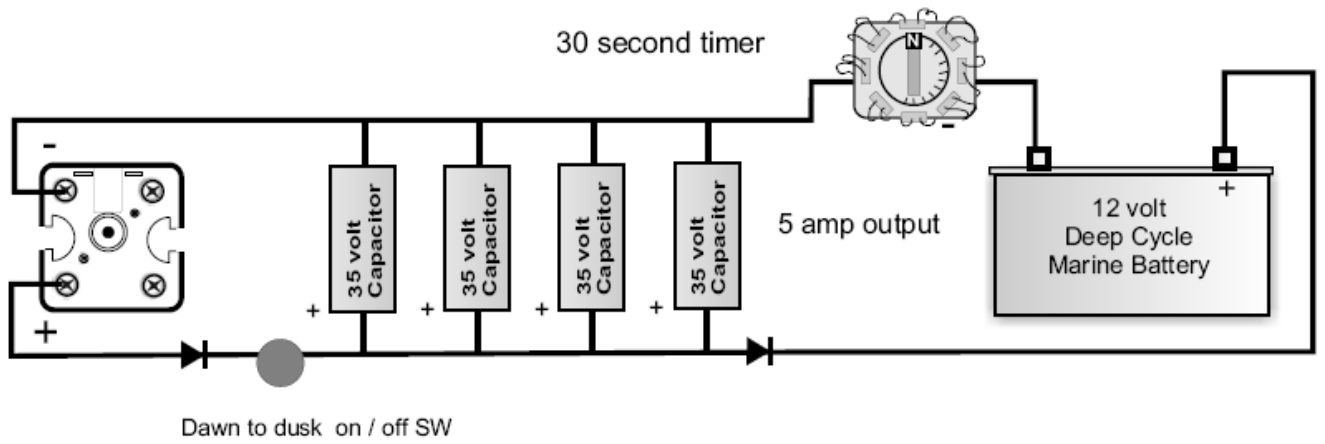

You can also build your own spring timer and relays by purchasing the necessary equipment.

## Timer Switching 4 PDT Relays

Electricity is constant when attached to multiple capacitor banks. By using a 9 volt battery the capacitor timer switches to charge each capacitor bank with their suitable timing (We used 2- 63 v x 4700 uf electrolytic capacitors). We also used a 100 watt 115 volt AC light bulb.

The setup description is:-

- ✚ 2 Capacitors connected in series
- ✚ Charge each capacitor by hand, then connect together in series
- ✚ Use a 12volt deep cycle battery charger, which runs a DC to an AC 115 volt inverter to transfer usable household energy to power a light bulb, an AC motor, TV, VCR etc.

We can produce 3 amperes every 30 seconds by charging a 35 volt x 4700 uf electrolytic capacitor bank. If you connect a large uf capacitors in parallel, it will increase the amperage but slow down the charge time. You can also setup the voltage to produce between 100

v and 150 v dc. To do this, you need to use three fully charged capacitors connected in series.

**Note:** - All components should be put in a safe place preferably a plastic box. Use all components professionally and keep it safe where no-one else has access to it.

# Grounding to Earth

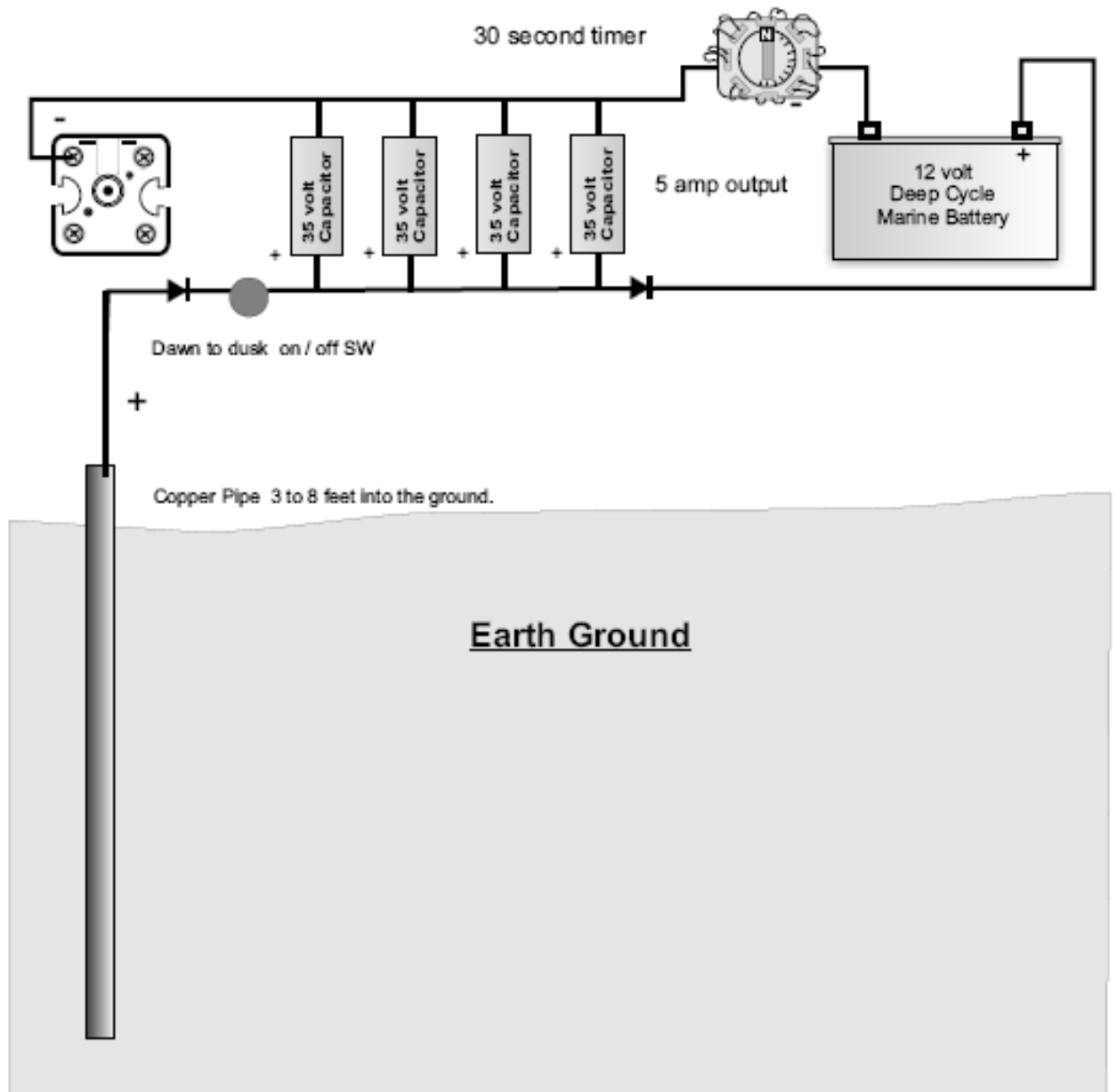

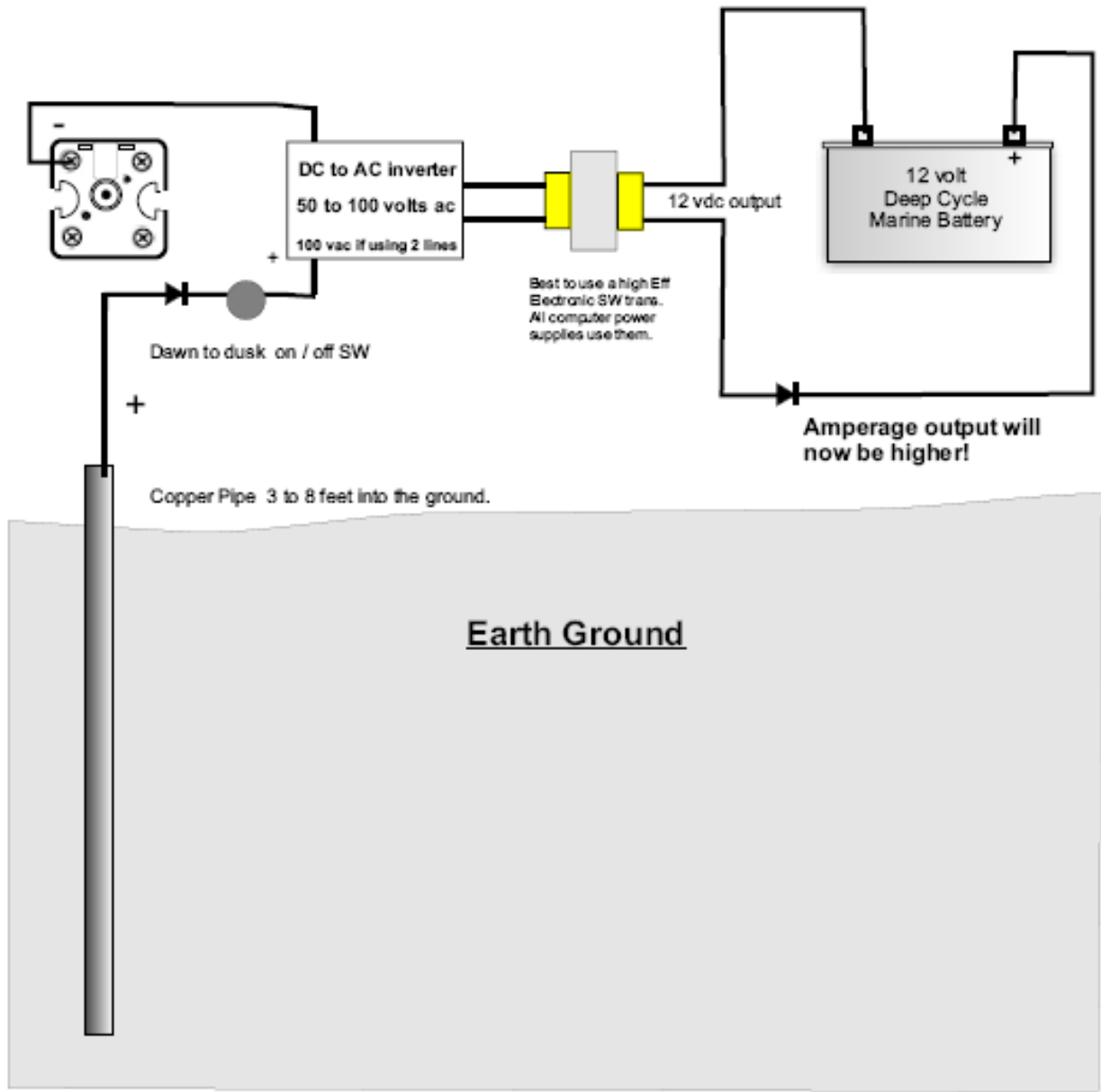

## A Simple but Effective Inverter



The purpose of the inverter is to invert the DC (Direct current) into AC (Alternating Current). Almost all household appliances run using Alternating Current. There are many household appliances, for example refrigerator, TV, VCR, computer etc. If you do not want to use an appliance which works with AC then you do not need an inverter, you can simply use a DC input. You can get DC input for approximately \$10. There are inverters available on the market which simply plug into your normal home power socket through which they

feed electricity back into your home. If you can use soldering gun then you can build a simple but very effective inverter as parts are easily available to purchase.

# High Voltage Power Supply/ DC to AV Inverter

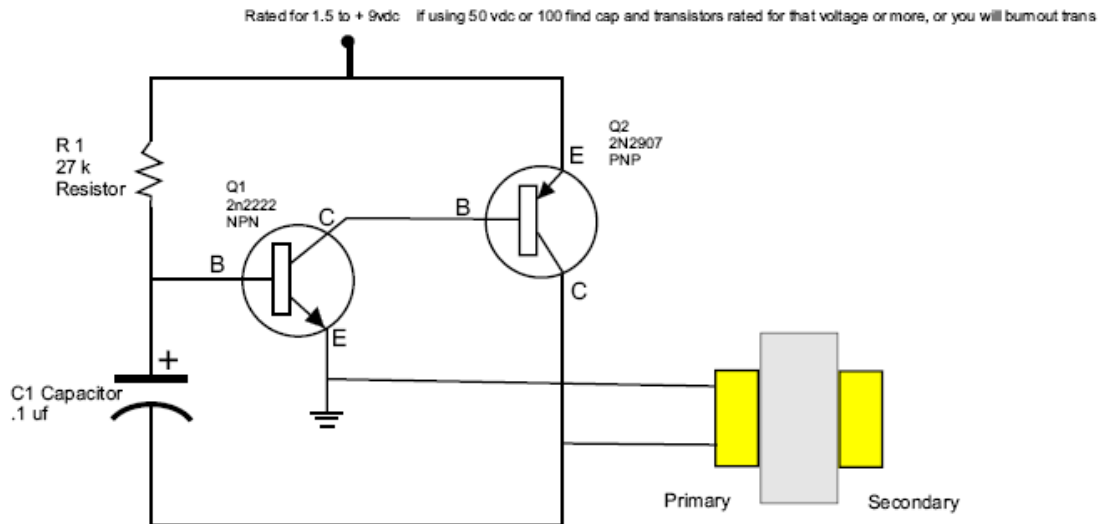

T1 = 6.3 v x 120v transformer This circuit will produce about 220 volts. Use a 1m resistor for higher volatges.

The circuit above is for low voltages but can be used on higher voltages if it is replaced with high rated parts. The 50 vdc must be changed into AC voltage current, or it will not work in a step up transformer or diode.

## Electricity Bank

By using a diode and a large 100 volt capacitor bank, you can light up your entire house by collecting 50 vdc. You must use a high efficient lighting source, such as ultra bright white diodes, white neon lighting or fluorescent bulbs. This works best for emergency lighting. The 50 vdc current you have collected will not light neon bulbs until the volts are much higher for example 300 to 5000 vac. A 15000 volt neon transformer can do it and pulse the 50 vdc into the primary part of the transformer using foot tines or a spring pulse switch. Alternatively you can build a low milliamp transistor type pulse generator which will turn the DC to AC collected from the secondary output of your transformer. You can also create a step up DC using photo capacitors which are 100% effective. For a quick experiment charge 20 to 50 volt capacitors, with each capacitor having about 4700 uf (micro farads), then charge the capacitor fully by hand. Connect these in a series using alligator clips, as with batteries - the wiring should be negative to positive.

**Warning! Use rubber gloves when working with High Voltage, High Voltage can kill!**



When you have connected them in a series, use a low amp isolation transformer. Connect the negative to primary and the positive. You will need to pulse the positive on and off very fast. The faster you do this the faster the pulse will be and the better the quality of output energy. Now connect the secondary leads from the isolation transformer to the ends of a fluorescent or neon light bulb (which you have to light up). Your pulse should be positive to the primary of the transformer. The bulb will light up and be very bright.



15,000 v Neon Transformer

Or you can pulse this homemade Tesla Coil to light a bulb!



# The Best Way of Collecting Electricity

The best way of collecting electricity is as follows. This method should be performed at night or when the phone line is not in use. To get 1 ampere at 15 vdc use a 10 volt capacitor to step down the 50 vdc that is coming from the lines (this is a special capacitor). Photo capacitors are always the best.

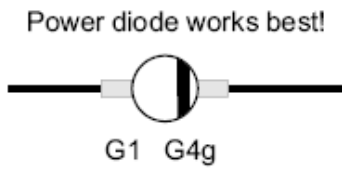
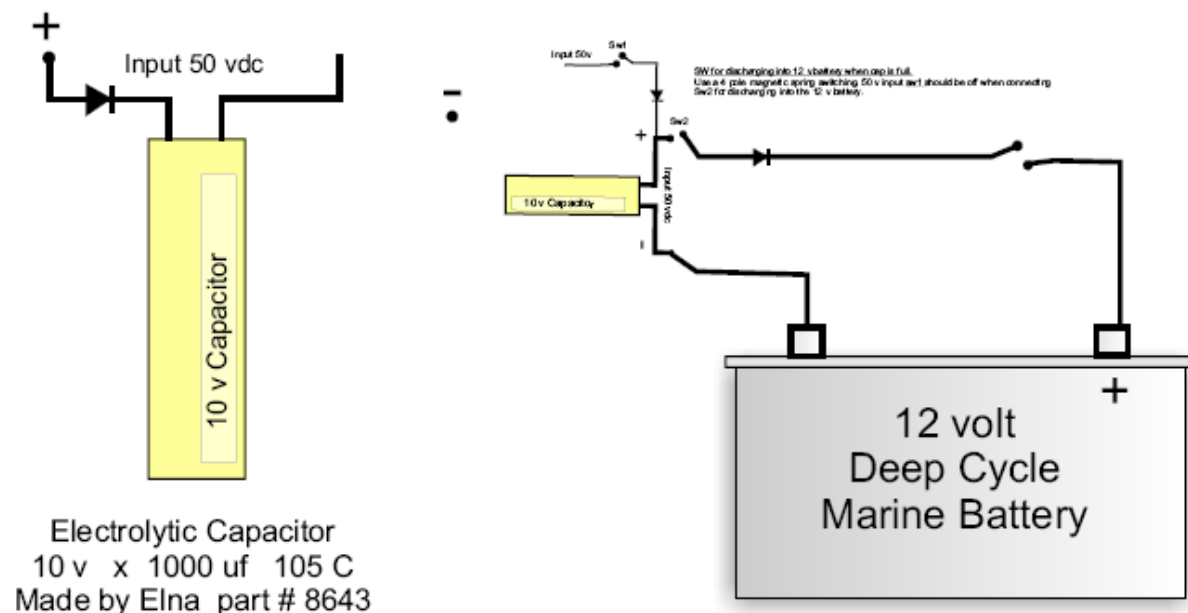

Let cap charge every 4 to 6 seconds, you may want to use a spring wind up timer for switching or use transistors as dc pulser to control 4 pdt relays which all can be powered from free energy from the earth method, ( See our free energy from the earth plans #459 \$29.95 plus \$3.95 shipping. ) Or you can use small magnetic reed switches ( about 10 ) placed and glued around a kitchen timer. Glue a small 1/4 diameter neodymium magnet to the rotating handle.

## High Voltage Care

When working with electricity you must always be very careful. High voltage or even a low voltage with high amperage can kill you if you don't use the correct safety procedures. If you are not familiar with high voltage you should not try this. The safety precautions that you need to observe when performing this are:-

- ⚡ Remember to wear gloves (Using rubber latex gloves works well for 50 V)
- ⚡ Remember to wear rubber soled shoes
- ⚡ Discharge all capacitors before you touch or work on them

You can also ground to the earth to get more electrical energy into the capacitor by using one negative from the telephone output.

Capacitors store and discharge free energy, radiant energy is stored between the capacitor plates, and the electrons are on the metal plates. Radiant energy is also created at discharge and the energy taken from elsewhere.

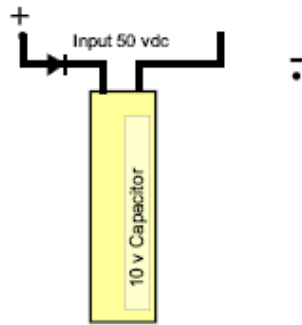

Electrolytic Capacitor  
 10 v x 1000 uf 105 C  
 Made by Elna part # 8643

Power diode works best!



# ***Finding New Ways to Secure Oil***

**Chapter 8**

## **Finding New Ways to Secure Oil**

Oil is used for anything that is gas powered including: cars, homes, and energy generation. Some of the issues we then face is trying to reduce the amount of energy we need and the amount of gas we use.

There are many ways to try and solve this problem. Automotive makers have already taken some of the first steps in reducing the amount of gas needed on hybrid cars. There are also more strict regulations on producing cars which cycle through gas too quickly.

Some diesel powered cars require a small amount of conversion to run fully on leftover fryer fat. Simply put, you can go into McDonalds, or any other fast food restaurant, and ask for the used oil and fat from the fryer.

It sounds a little farfetched, but the vehicle will run with no problems and no damage will be done to the engine or fuel lines. The only downside is that your car will smell like fried food. This is commonly known as 'rough biodiesel'.

The waste from the fryers, oil or fat, can go through a refining process. This refined product is called biodiesel, and it has many of the exact same properties you would find in Diesel. The car will act no different with biodiesel or with regular diesel.

Standard diesel vehicles these days allow you to use refined biodiesel without the use of a conversion kit. You can refine other waste products and use them as biodiesel such as fat from: pork, beef, poultry, or vegetable oils.

Another way cars are reducing their dependency on oil is the use of electricity to power the vehicle; these are known as hybrid Electric Cars. These cars and trucks are getting more popular and more mainstream as people are realizing how much money they can save on gas. The vehicles motors are build to use both gas and battery power to operate. When these cars break, they capture kinetic energy which is used to recharge the battery.

Due to their low emissions and excellent gas mileage, these vehicles are considered to be environmentally friendly. Some of the most popular brands are the Toyota Prius and the Honda Insight.

Along with the Hybrid electric cars, there are also fully electric cars. These vehicles rely solely on an electric motor to move the vehicle. The vehicles use something different than the standard internal combustion engine. The fully electric cars are still in development and aren't as popular as the Hybrids, but they seem to be the wave of the future.

The electric cars run on electricity alone which gives them a limited range they can travel. It is less expensive to recharge the battery than to buy gas, but the batteries don't last long enough to get you more than 40 miles at a time. The technology is still in the works, but there are many vehicles using it already.

-----End-----