

Conspiracies • Behind the News • Health • UFOs • Future Science

NEXUS

NEW TIMES • Vol 5, N° 3

The MAI: Transnationals
at the trough

The Jesus Conspiracy

Garrett's Water-Powered Car

Secret Tunnels of the Giza Plateau

The UFO Cabal Exposed:
an insider speaks out

APRIL - MAY 1998

AUSTRALIA \$4.95

NZ (incl GST) NZD \$5.95

USA USD \$4.95

CANADA CAN \$5.95

UK STG £2.50

NETHERLANDS NFL f8.95



ISSN 1039-0170

9 771039 017000

Print Post Approved PP442036/0005

+ Atlantis in Antarctica • MIBs • Rife • WW2 Fluoride Secrets

NEXUS

NEW TIMES MAGAZINE

Volume 5, Number 3 APRIL - MAY 1998

PO Box 30, Mapleton Qld 4560, Australia

CONTENTS

LETTERS TO THE EDITOR.....4	INSIDE REVELATIONS ON THE UFO COVER-UP.....53
GLOBAL NEWS.....6	<i>By Richard Boylan. In this interview, Dr Michael Wolf, a scientist who has worked in highly classified projects, makes startling disclosures about the US Government's agenda on UFOs and ETs.</i>
<i>A round-up of the news you may have missed.</i>	THE TWILIGHT ZONE.....61
TOXIC SECRETS: FLUORIDE & THE A-BOMB.....13	<i>Strange tales from around/within/beyond the world. Featured here is an interview with documentary film-maker Boris Said about the secret tunnels, and the politics, of the Giza Plateau in Egypt.</i>
<i>By Joel Griffiths & Chris Bryson. Manhattan Project scientists and military men who developed the first atomic bomb also conducted secret studies of fluoride but hid the facts about its health hazards.</i>	MEN IN BLACK: A CLOSE ENCOUNTER—Part 2....67
THE HIDDEN HISTORY OF JESUS—Part 2.....21	<i>By Albert K. Bender. We conclude our coverage of this pioneering ufologist's 1953 encounter with aliens who transported him to their Antarctic base and revealed fascinating details about their mission.</i>
<i>With Sir Laurence Gardner. The original Gospels were not only mistranslated and misinterpreted, they were deliberately amended by the early Church bishops to obscure the truth about Jesus.</i>	REVIEWS—Books.....75
MAI GALOMANIA! THE MAI AGREEMENT—Part 1.....29	<i>"Cannibals, Cows & the CJD Catastrophe" by Jennifer Cooke</i>
<i>By Corporate Europe Observatory. Moves to establish the Multilateral Agreement on Investment are designed to put more power and resources in the hands of transnational corporations at the expense of people and governments globally.</i>	<i>"Hitler and His Secret Partners" by James Pool</i>
DR RIFE'S RESONANT ENERGY DEVICE—Part 2.....37	<i>"Food Pets Die For" by Ann N. Martin</i>
<i>By James E. Bare. This article concludes with further analysis of Dr Royal R. Rife's cancer-curing radio-frequency unit and comparison with other historical resonant-energy therapeutic devices.</i>	<i>"Lost Science" by Gerry Vassilatos</i>
ATLANTIS IN ANTARCTICA?—Part 1.....43	<i>"Eating with Conscience" by Dr Michael W. Fox</i>
<i>With Rand Flem-Ath. Having studied Plato's accounts, ancient maps and geological records, this researcher argues that the legendary lost continent of Atlantis is actually Antarctica!</i>	<i>"The Water Wizard" edited by Callum Coats</i>
NEW SCIENCE NEWS.....49	<i>"Voyages into the Unknown" by Bruce Moen</i>
<i>Interesting news and views from the underground science network. In this issue we highlight Charles Garrett's 1935 patent on an electrolytic carburettor that can split hydrogen from water and combust it immediately without any need for storage.</i>	<i>"Genetic Engineering: Dream or Nightmare?" by Dr Mae-Wan Ho</i>
	<i>"The Spacing of Planets" by Alexander Alan Scarborough</i>
	<i>"Summer with the Leprechauns" by Tanis Helliwell</i>
	<i>"Ancient Micronesia & the Lost City of Nan Madol" by D. Childress</i>
	<i>"Perpetual Motion: An Ancient Mystery Solved?" by John Collins</i>
	<i>"The Magic Square of Three Crystal" by Arto Juhani Heino</i>
	<i>"Bombs, Bliss & Baba" by Paul Narada Alister</i>
	<i>"Black Helicopters II: The Endgame Strategy" by Jim Keith</i>
	REVIEWS—Product.....82
	<i>"MindLab Orion" from Lifetools</i>
	REVIEWS—Audio.....83
	<i>"Simple Magic" by Dee Rogers</i>
	<i>"Ó'r Mabinogi: Legends of the Celts" by Ceredwen</i>
	<i>"Essence" by Peter Kater</i>
	<i>"Dakar Heart" by Jimi Mbaye</i>
	<i>"The Holy Spirit and The Holy Grail" by Adrian Wagner</i>
	NEXUS BOOKS, SUBS, ADS & VIDEOS.....96

NEXUS MAGAZINE

Volume 5, Number 3

APRIL – MAY 1998

PUBLISHED BY

NEXUS Magazine Pty Ltd, ACN #003 611 434

EDITOR

Duncan M. Roads

CO-EDITOR

Catherine Simons

ASSISTANT EDITOR/SUB-EDITOR

Ruth Parnell

EDITORS' ASSISTANT

Richard Giles

OFFICE ADMINISTRATOR

Janine Carmichael

CONTRIBUTORS THIS ISSUE

Joel Griffiths and Chris Bryson; Sir Laurence Gardner, Kt St Gm, KCD; Corporate Europe Observatory; James E. Bare, DC; Rand Flem-Ath; Jerry W. Decker; Richard Boylan, PhD; Kenneth and Dee Burke; Albert K. Bender (dec.)

LAYOUT & DESIGN

Duncan M. Roads

CARTOONS

Phil Somerville

COVER GRAPHIC

John Cook, jscook@ozemail.com.au

PRINTING

Warwick Daily News, Queensland, Australia

AUSTRALIAN DISTRIBUTION

Newsagents Direct Distribution

HEAD OFFICE - All Correspondence

PO Box 30, Mapleton, Qld 4560, Australia.

Ph: (07) 5442 9280; Fax: (07) 5442 9381

E-mail address: nexus@peg.apc.org

Web page: <http://www.peg.apc.org/~nexus/>

NEW ZEALAND OFFICE - PO Box 226, Russell,

Bay of Islands. Ph: +64 (0)9 403 8193;

Fax: +64 (0)9 403 8196;

E-mail address: nexusnz@xtra.co.nz

USA OFFICE - PO Box 177, Kempton, IL 60946-

0177. Ph: (815) 253 6464; Fax: (815) 253 6454

E-mail address: nexususa@earthlink.net

UK OFFICE - 55 Queens Rd, East Grinstead, West

Sussex, RH19 1BG. Ph: +44 (0)1342 322854;

Fax: +44 (0)1342 324574;

E-mail address: nexus@ukoffice.u-net.com

EUROPE OFFICE - PO Box 372, 8250 AJ Dronten,

The Netherlands. Ph: +31 (0)321 380558;

Fax: +31 (0)321 318892;

E-mail address: frontier@xs4all.nl

STATEMENT OF PURPOSE

NEXUS recognises that humanity is undergoing a massive transformation. With this in mind, NEXUS seeks to provide 'hard-to-get' information so as to assist people through these changes. NEXUS is not linked to any religious, philosophical or political ideology or organisation.

PERMISSION-TO-REPRODUCE POLICY

While reproduction and dissemination of the information in NEXUS is actively encouraged, anyone caught making a buck out of it, without our express permission, will be in trouble when we catch them!

Editorial

This issue of NEXUS will be read by more people in more languages than ever before. Thus we extend a warm welcome to our new readers in Greece, Japan, Poland and Sweden, where NEXUS can now be found in their respective languages. Thank you for your interest!

While I'm at it, if anyone knows a foreign-language magazine publisher interested in expanding their range, please put them in touch with us as we have many other international readers wanting the magazine in their own language.

And just in case you think NEXUS is published by a large number of Mulders and Scullys working out of plush city offices with frills and mod-cons—forget it! There are only six of us here, working out of a done-up shed well away from bright city lights. By "done-up" I mean it now has a reverse-cycle air-conditioner and the wildlife doesn't sneak, grow or slither in under the walls so much any more.

I mention this so that readers still waiting for me to answer your letters, discuss your articles or read your books will excuse me if it takes a while. If we can publish what you have sent sooner than later, you will hear from us pronto! Be aware that I receive hundreds of e-mails per day, dozens of magazines, newspapers, newsletters, articles as well as books, CDs and videos for review, not to mention the phone calls. Interspersed with the above are lots of many-pages-long, handwritten letters. I would love to be able to answer each and every enquiry, but I can't, so please don't take it personally if you don't get a reply from us. Thank you also for your many, many letters of support and encouragement. For every one letter of criticism, we get about 50 of praise.

We are also pleased to announce that we WILL be holding our annual NEXUS Conference again, largely due to the many phone calls from readers and previous attendees requesting another conference. You will see from the advert inside that we have great range of speakers already confirmed, with more to come. Fans of *Bloodline of the Holy Grail* will be most pleased to know that Sir Laurence Gardner will be one of our guest speakers. Michael Cremona, author of *Forbidden Archeology*, is also on the speakers list.

On another note entirely, I would like to discuss advertisers and advertising. I have had to refuse several adverts lately, on the grounds that the wording of the advertisement was grossly misleading and, in a couple of cases, downright insulting to what I perceive as the intelligence of our readers. Nevertheless, I make the eternal plea that everyone should remember that just because someone advertises in NEXUS, it does not mean that their product/service has our endorsement. So please let us know if you are unhappy with an advertiser or their products or services and we will see what we can do.

While on this subject, I must comment on the increasing number of mail and telephone enquiries we receive, asking: "Are the white powder gold products on sale as advertised in NEXUS and many other magazines the same as the original David Hudson white powder gold?" (see NEXUS 3/05, 3/06). The answer is a firm NO! Dave Hudson's white powder gold is not yet on the market, but when it does come onto the market...lookout, world!

Now, onto the articles in this issue. Please inform yourselves about the MAI and tell your local politician what you think of it. The article inside represents the most comprehensive information on the subject we could find.

I would also like to draw your attention to the Michael Wolf interview by Richard Boylan. It contains some interesting UFO tidbits which I'm sure will keep tongues wagging amongst the many armchair UFO 'experts' out there.

Finally, the Boris Said interview in Twilight Zone is an interesting update for those wanting more information in the Pyramids/Sphinx tunnels explorations.

Duncan

WARRANTY AND INDEMNITY

Advertisers upon and by lodging material with the Publisher for publication or authorising or approving of the publication of any material INDEMNIFY the Publisher and its servants and agents against all liability claims or proceedings whatsoever arising from the publication and without limiting the generality of the foregoing to indemnify each of them in relation to defamation, slander of title, breach of copyright, infringement of trademarks or names of publication titles, unfair competition or trade practices, royalties or violation of rights or privacy AND WARRANT that the material complies with all relevant laws and regulations and that its publication will not give rise to any rights against or liabilities in the Publisher, its servants or agents and in particular that nothing therein is capable of being misleading or deceptive or otherwise in breach of the Part V of the Trade Practices Act 1974. All expressions of opinion are published on the basis that they are not to be regarded as expressing the opinion of the Publisher or its servants or agents. Editorial advice is not specific and readers are advised to seek professional help for individual problems.

© NEXUS New Times 1998

Letters to the Editor ...

CIA's National (in)Security

Dear Editor: CIA looking for national security leaks? Puleeze, gimme a break. Among the great absurdities of our time that in all likelihood will have to be documented by historians—mainstream media, as in the case of Monica Lewinsky, certainly won't—is the AP's latest announcement that the CIA is investigating the Executive Branch for security leaks that "jeopardize national security".

To understand just how absurd this is, one has only to consider the following: that this is the same CIA whose Soviet counter-espionage chief sold all its major secrets to the KGB for eight years with all the secrecy of a New Jersey garage sale; the same CIA, several of whose historians recently resigned in disgust, calling their "history"—currently being compiled at taxpayer expense—a "fraud and a whitewash"; the same CIA that a congressional committee, headed by Porter Goss (Florida, R.), himself an ex-CIA agent, called "poorly trained" and "unprepared to do their job"; the same CIA that was accused by DEA head Judge Bonner on *60 Minutes* in November of 1993 of being drug smugglers; the same CIA whose latest "secret" failure to topple Saddam Hussein, according to foreign journalists, cost tens of thousands of lives and the American taxpayer \$275 million, and was due to "gross ineptitude".

This is still the same CIA about whom Lyndon Johnson once said: "When the rich folks don't trust their sons with the family money, they send them on up to the CIA."

Well, as an insider with 25 years as a Federal enforcement officer, I want to attest to the fact that nothing has changed. Except that I didn't know that they had authority to conduct investigations inside the US. Have I missed something?

In any case, if the CIA is investigating the Executive Branch for leaks, you can bet it has a lot more to do with protecting their sorry image than national security.

Sincerely, Mike Levine, "The Expert Witness Show", WBAI, New York, rocamora53@aol.com

Heavy Attack on Light Theory

Dear Duncan: A gem in NEXUS Dec '97-Jan '98 [5/01] caught our interest: the review of

Peter Bros' book, *Where Science Went Wrong*. Science suppresses the fact that no one knows the nature of light or gravity, and that $E = hf$ and $F = GMm/r^2$ respectively are mere quantitative *descriptions*, not theories of science. Ironically, only the social and biological sciences are now based on mechanistic theories and explanations; physics has become pure mathematical magic! We agree, and are exposing this conspiracy.

On page 46 of the London *Times* newspaper, 21 Oct '97, we publicised a summary of the Catt, Davidson and Walton discovery that the "electromagnetic theory of light" is totally misconceived. James Clerk Maxwell in 1865 based it upon the assumption that metal wires are "solid" and are thus physically distinct from space (like the gap between capacitor plates in a circuit, or the space between the transmission and reception aerials in radio communication).

In fact, we truly know from X-rays that atoms are not solid; they are mainly empty *space*. We also know that electrical energy always travels at "the speed of light", not at the 1 cm/s so-called drift speed of electrons in textbook electric current! You do not need to wait minutes for your light to come on after pressing the switch, or for your calculator to add, or for energy to be oscillated up and down a radio aerial.

Electricity is composed of two effects, by analogy to sound and wind in the air. Air molecules move at sound-speed (their impacts cause air pressure), and this is physically why any excess pressure is propagated through the air at the average particle speed. Hence, if you feel a 10 mph breeze on one side of your hand, air molecules are colliding on that side at 650 mph and at only 640 mph on the other side. This *difference* in the speeds is what we sense as "wind". Electrons are spinning vortices of space; the spin plus other motions (orbital speed, etc.) always add up to "the speed of light". In fact, Maxwell's "theory of light" must apply not to light but to electric energy waves in wires (by analogy to sound in air) delivering energy at light-speed. The other effect of electricity, so-called electron drift, is an analogy to the slower-than-sound wind-speed illusion already described.

Since Einstein's relativity is based upon Maxwell's light (really, electricity inside conductors), our researchers have used this physical explanation of electricity to understand and explain the basis of physics.

Yours sincerely, Nigel Cook, Publisher, *Science World* magazine, Addlestone, Surrey, UK.

Tasmania's Monster Mystery

Dear Duncan: Once again "the powers that be" have successfully covered up one of the most important discoveries of the century. I refer of course to the unidentified life-form washed up on the beach near Sandy Cape in Tasmania, found just before Christmas 1997.

This story received scant media attention, mostly being relegated to the human interest section of most of the major newspapers, whilst the electronic media were more concerned with local sporting events. I found this hard to comprehend, especially since a similar organism was found in the same area 37 years previously.

When the "monster" of 1960 was found it created a media storm, being front page news in Sydney for several consecutive days. A government biologist, Dr Bruce Mollison, had travelled to the remote site in the wilds of southwest Tasmania and examined the carcass and was quoted as saying that it was neither "fish, fruit or fowl". Samples were taken for analysis and the scientists on the site reported that the hide was extremely difficult to cut with a knife, yet when heat was applied from a cigarette lighter the flesh seemed to "retract". Several international consortiums were interested in recovering the carcass for scientific examination.

Then the authorities stepped in. A prominent minister at the time (a former fighter pilot with the RAAF who later became Prime Minister) took over the investigation and declared that the samples taken were found to be whale blubber, despite the protestations of the scientists who had examined the creature. The specimens were filed and the carcass mysteriously "washed back into the sea" (though it was estimated to have weighed four tonnes!). The media then suddenly dropped the story.

It's interesting to note the parallels between this case and the

creature found recently. Already, the few articles in the papers have mentioned whale blubber and have tried to trivialise the issue.

I wait with bated breath for an excuse to be peddled out by the powers that be!

Yours faithfully, Geoff C., Minto, NSW, Australia.

Toxic Vaccines & Sunscreens

Dearest Duncan: Why is it I am not surprised by your article, "Governments vs the People: Crimes Against Humanity"? [NEXUS 5/02] They expect us to hand over our children's health so they can stick who knows what into their little bodies while telling us that these "vaccinations" are good for them! Who-knows-what they contain that we are not told about, let alone the poisons that we know *are* present. How many of our children are being given more than the basic vaccine, toxic in itself, with possible experimental chemicals also being unsuspectingly administered?

Vaccination of humans, animals and birds is the fourteenth largest industry in the world. It is the profiteers who urge us to vaccinate. Governments, pharmaceutical companies and doctors all get their cuts. (I would be interested to know how many informed doctors vaccinate their children.)

I urge people with children to do research before getting their children inoculated. There are natural alternatives to build the immune system. Don't let your child be an experiment or, worse, a statistic.

Incidentally, I would love to see an article on sunscreen and its relation to the increase of skin cancer. I believe the ingredients may be the reason for the sharp rise in skin melanomas. If you think about it, the rise in skin cancers seems to coincide with the big push to buy sunscreens. They contain chemicals from petroleum companies (scary enough) and our skin acts as a sponge, absorbing it all. We need this propaganda and profiting from people's health stopped. Thanks.

Regards, Veronica W., Two Wells, South Australia.

Iraqi Weapons & Big Business

Dear Editor: Foreign Affairs Minister Alexander Downer yesterday (12 February) defended Australian involvement in a gulf

... more Letters to the Editor

NB: Please keep letters to approx. 100-150 words in length. Ed.

war. Iraqi stockpiles of Vx nerve gas would be enough to poison the whole world!

Iraq has 600 unaccounted-for tonnes of raw materials which could be used to produce 200 tonnes of nerve gas. Iraq has 17 tonnes of unaccounted-for biological weapons material which could produce triple that amount of anthrax bacterial disease weapons.

Mr Downer said: "Twenty-eight grams or one ounce of anthrax bacteria in the air-conditioning system of a sports stadium could infect 70,000 people." (*Morning Bulletin*, 16 February) It's all true, but he didn't say that a British company sold all this deadly material to Iraq!

The BBC, broadcasting from London at 11 pm on 14 February, reported that the *Daily Telegraph* wrote a story about who did business with Saddam Hussein between 1991 and 1994, selling very dangerous material with the possible effect of the massive destruction of people. Only 385 pounds of this deadly material can kill three million people. This material has been sold by an Anglo-Dutch company with British conservative government permission: an export licence. With 2,000 pounds of this material it is easy to make anthrax, the most deadly biological weapon on this planet. All this material was transported in four shipments labelled as "Dental-Medical Material".

Today, when our Prime Minister Howard is saying that Australia is in danger, he is telling the truth because the British Government and big business people with a vision for profit sell atomic bombs or anthrax to anyone who has the money! So, 385 pounds can kill three million people, and 3,000 pounds can kill 15.5 to 24 million people.

We small people of the planet must hope that Saddam Hussein has more brains and responsibility than the USA-Britain-Australia alliance. How much deadly material has Saddam Hussein obtained from other countries? Our lives are in his hands. If our media only knew it, the danger to Australia is coming from a very different direction, and political lying can kill millions of innocent people.

Take this notice, electors: you must take responsibility for your

children at the next election. Lazy thinking sometimes means that you dig your own grave—for yourself and for your children.

Robert N., Emu Park, Queensland, Australia.

Investing in Free Energy

Dear Mr Roads: We are a Brazilian financial group acting in the market of components for musical instruments. Recently we decided to invest in the serial production of devices which can promise a return for investment in the fields of free energy, antigravitation and inertial thrust.

Our purpose is to provide for the self-sufficiency of little- and medium-sized alternative-minded human groups, firstly on the energy and locomotion level, making them independent from mega-concerns. The rest of the development of our intentions certainly shall come as a consequence, covering the whole human society in a progressive way, avoiding the social tensions of a substantial direction change like this, perhaps over some decades.

Please, if you also have the same intention for mankind, we would be grateful to you for publishing our letter, in order that we may provide financial support for researchers who have some positive device or achievement in this direction. We would also provide the industrial production.

Truly yours, Dr-Ing. Eugene V. Follmann, Presidente, Follmann & Sons Ltd, Rua 3 No. 570, Jardim Henrique Martins, CEP 07600 000, Mairiporã, São Paulo, Brazil.

Health Freedoms Threatened

Dear Citizen: By now most readers have heard of the government/pharmaceutical industry agenda to regulate all natural nutritional substances. The story of how the Governor-General of Australia signed the Therapeutic Goods Act bill on 19 December 1997 while everyone was distracted, preparing for Christmas, will no doubt be a classic story in the history of sleazy underhanded political moves of the century. However, many citizens of Australia may not know the story behind the story about the Codex.

After the Second World War, the war where many Australian lives were lost fighting the Nazis, the Nuremberg trials tried and judged

many of the leaders of the Holocaust including the pharmaceutical company in Germany that manufactured the gas that killed the Jews.

After the trial was over, this company was disbanded and separated into three different companies, one being the Bayer pharmaceutical company famous for its aspirin products. In recent years since the war, these companies have amalgamated, re-creating the once-powerful cartel that served Nazi Germany. It is this company that has created the Codex.

This information was researched by Dr Zoltan Rhona of Toronto, Canada, and has proven to be reliable. Unfortunately for our Canadian friends who are known for their passivity, their government has allowed the rights of their citizens to be extinguished by the powerful pharmaceutical Nazis offering huge financial rewards to their government and the pharmaceutical industry.

Now it's Australia's turn and it's happening fast unless we write to our members of parliament and let them know the truth. In the US the citizens have managed to keep Codex out. What is in store for Australia?

The Codex agenda is to control not only the herbs, homeopathic remedies, etc. that we would expect, but also minerals from the soil, chlorophyll, plant enzymes, sugars, essential oils, algae and even bee pollen. Big Brother has arrived in Australia and he is a storm trooper in disguise. They have added books and literature concerning natural food remedies to their domain. We have only until March to voice our concerns.

G.F., Western Australia.

House of Stewart or Stuart?

Dear Editor: I am just reading "The Hidden History of Jesus and the Holy Grail" [5/02]. I note the following sentence: "This was a dynastic Order of Scotland's Royal House of Stewart." As any true Scotsman knows, there are two spellings of Stewart and Stuart. The Stuart spelling is the royal spelling. Therefore the sentence should read: "This was a dynastic Order of Scotland's Royal House of Stuart." A very important difference to a Stuart. A major error!

Thanks, A Stuart's girlfriend.
[Dear girlfriend of a Stuart:

According to author/speaker Sir Laurence Gardner, in Scottish terms the name has always been "Stewart". Mary, Queen of Scots emerged from her childhood in France with the name "Stuart", as there was then no 'w' in the French alphabet. This spelling persisted in Britain through the balance of the reigns of her heirs and for the *de jure* family until 1892. Mary's grandson, James VI of Scots (James I of England) is generally referred to as a Stuart. Ed.]

Eclectic Madness and Insight

Dear NEXUS: I've been reading your mag for over a year now and from the first time I opened its rough pages I knew I was in for an interesting read. Having dipped my toe in the pool of "alternative" thought (is there a better phrase: unpopular/fringe/heretical/unconventional, perhaps?) for about two years now, I find your mag a reliable and exciting source of eclectic madness and insight (in about equal measure!). Well done!

Prior to my discovery I had assumed that such subjects as alternative history, forbidden science, the global elite conspiracy, alien paradigm, etc., were the sole preserve of *lone crackpots*! It was a great relief to realise that there were thousands of (seemingly!) sane, like-minded people around the world, each with views and suspicions, determinedly trying to find their own answers, unwilling to accept what "they" want...

The articles are usually well written and referenced. And there is often something you'd never read elsewhere, such as "reverse talking". I have particularly enjoyed the recent Harry Mason articles and the multiple implications of his theories. And I always enjoy reading David Guyatt's pieces and anything on the money system generally.

My praise is not unreserved, for I suspect that each issue contains both misinformation (accidental) and disinformation (intentional) amongst the information. But then, this is inevitable in a magazine such as this. And it is our job as readers to try to distinguish between the varying, sometimes conflicting, tales...

Best wishes, Hugh G., Irby, Wirral, Merseyside, UK.

(Hugh, if there is any disinformation in NEXUS it is unintentional. Ed.)

LET THERE BE LIGHT COMPUTERS!

Super virtual-computers which use light-beams in place of wires and circuitry should soon become a reality, thanks to Australian research.

Light beams are better than conventional electronics for computing and communications because nothing travels faster, and because they have no mass and suffer less from interference. They can even pass through each other without distortion. It means scientists will soon be able to create transparent computers the size of a sugar cube with millions of components and circuits all consisting of light alone.

Research by professors Allan Snyder and John Mitchell, at the Centre for the Mind at the Australian National University, is leading the world in optical computing. Professors Snyder and Mitchell base their work on light waves called "solitons" which are the building blocks of the technology required to make light guide light.

Professor Snyder calls solitons the "ultimate surfer's wave" because they go on and on without losing shape or form. Normally, light-waves dissipate and need optical fibres to contain them, but solitons create their own channels. Previously it was thought that only high-powered lasers could guide other light sources, but the ANU team has shown that an ordinary light bulb can also work in this way.

The ANU research will make it possible for engineers to conceive and design experimental models. Professor Snyder



believes the work will lead to viable new technology.

"Light controls its own destiny," Prof. Snyder said. "The question remains whether we can harness it to control ours." (Source: © Mark Thornton, alanthor@net-info.com.au)

NUKE WASTE MAY BE RECYCLED INTO CONSUMER GOODS

A controversial Directive passed by the European Council of Ministers in 1996 will allow the nuclear industry to dump radioactive waste in landfill tips, burn it, or recycle it into consumer goods.

The Directive Euratom 96/29, when it becomes law by the year 2000, will permit the release into the environment or the recycling of nuclear waste without any need for reporting or authorisation, so long as the concentration of radioactive sub-

stances in the waste is below thresholds set out in the Directive.

You guessed it: the thresholds are ridiculously lax, up to a million times more so than present law in the UK permits.

To find out more, phone the Low-Level Radiation Campaign in the UK on +44 (0)1970 824771 or visit its Internet website, www.llrc.org. (Source: Brochure issued by the Low-Level Radiation Campaign, Ammondale, Spa Road, Llandrindod, Wells, Powys LD1 5EY, UK)

US FDA REFUSES BAN ON ANIMAL ORGAN TRANSPLANTS

Despite increasing evidence that animal viruses are capable of infecting human cells, the US Food and Drug Administration (FDA) will not ban the transplantation of animal organs into humans.

Xenotransplantation at this stage primarily involves the transplanting of organs from genetically altered pigs into humans. The pigs are genetically altered so as to make the human body unlikely to reject the pig organs.

However, leading researchers are continuing to find pig retroviruses capable of infecting human cells (*Nature* 389:681-82, 16 October 1997) and are thus calling for a moratorium.

"Will there be a moratorium? No, we do not plan to do that," Michael Friedman, acting FDA commissioner recently told a meeting held near Washington, DC, to discuss the issue.

(Sources: Australian Doctor, 5 December 1997; New Scientist, 24 & 31 January 1998)

US WEAPONS CONTRACTS IN JEOPARDY IN S-E ASIA

On the surface, the 12-day tour of Asia in January by US Defense Secretary William Cohen appeared to convey his government's commitment to stability and security in South-East Asia. Beneath the surface, however, one realises that the real purpose of Cohen's visit was to shore up arms contracts in danger of collapse due to the regional economic crisis.

US arms exports are tipped to total US\$16 billion in 1998, with a quarter of this destined for Asia. The falling value of Asian currencies in recent months has seen Indonesia, Japan, Malaysia, South Korea,

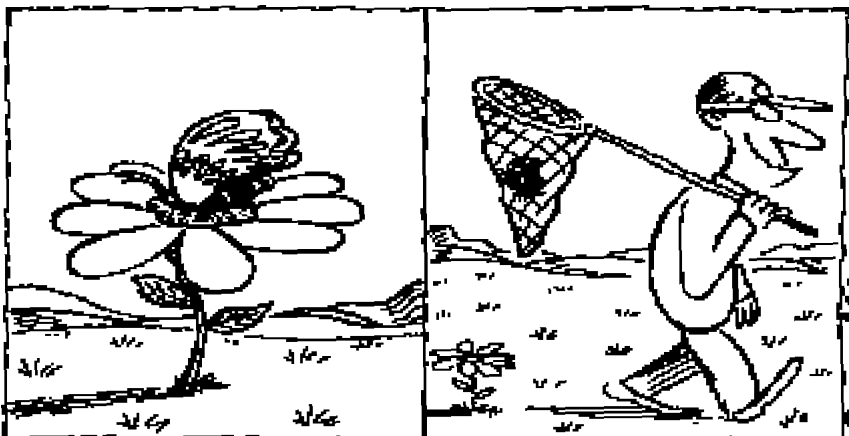

HOME ADDRESS

NET ADDRESS

Thailand and the Philippines move to cancel or suspend significant arms purchases. An example is Thailand's request to renegotiate the US\$390 million contract for eight F-18A jet fighters.

A special assistant from the US Treasury accompanied Cohen to advise Asian government leaders on how their arms repayments could be extended, rolled over or paid off in some other way.

(Source: Green Left Weekly, 18 Feb 1998)

ARCHAEOLOGICAL TURMOIL OVER ANCIENT SITE IN CHILE

The discovery of a site some 12,500 years old in Monte Verde, Chile, has thrown the archaeological world into uproar. The site is 1,300 years older than the previously oldest known site, and it is about 16,000 km away from the Asian-Alaskan land-bridge over which the first Americans are thought to have migrated.

Given that massive glaciers covered much of the continent at that time, the first settlers could have migrated between 14,500 and 40,000 years ago.

(Source: Reuters; Sydney Morning Herald, 18 February 1998)

STORM OVER AGE OF AUSTRALIAN ROCK CUPULES

Is mainstream science rejecting controversial research data because it does not conform with accepted parameters?

In September 1996, the *Sydney Morning Herald* announced to the world that a team of scientists had found Aboriginal rock art and stone tools at Jinmium in the remote Northern Territory, which implied that the first people arrived in Australia between 116,000 and up to 176,000 years ago—more than 100,000 years earlier than scientists had believed. Naturally, if this were shown to be true, the entire global history of man would have to be rewritten.

It would have been obvious to the team of four scientists—David Price, Paul Taçon, Lesley Head and Richard Fullagar (the team leader)—that this was no small announcement, and no doubt they checked and rechecked their findings very carefully before making the announcement that would either make them or break them.

Predictably, the interest was immediate and intense, resulting in a very hectic year for all four scientists. Despite the pressure, they stuck to

their research and chronology.

At that point, strange things started to happen: Fullagar's application to the Australian Research Council for funding to continue the research was unsuccessful; and an article about the Jinmium controversy appeared in an obscure publication, the *National Pictographic Society News Letter*. The article was published under Dr Paul Taçon's name and contained many factual errors and unattributed quotations. Taçon, though, has never heard of the society, nor did he have anything to do with the piece. He is now considering legal action.

In December 1997 the *Sydney Morning Herald* made another splash on the subject by announcing that "new dating techniques" had revised this figure from the 176,000 maximum to 40,000 years and possibly only 10,000 or 5,000 years. It seems that a new team of 'experts' has found reason to reinterpret Fullagar's team's findings.

However, team member David Price, a geochronologist at the University of Wollongong, stands by his dating. He strongly disagrees with the contention that he fell into a "methodological misconception" on a technical matter.

(Source: SMH, 23 December 1997)

FAVOURABLE CANNABIS REPORT COVERED UP

Officials at the World Health Organization (WHO) in Geneva have suppressed the publication of a politically sensitive report that confirms what ageing hippies have known for decades: cannabis

is safer than alcohol or tobacco.

According to the report which was leaked to *New Scientist* magazine, the analysis concludes not only that the amount of cannabis smoked worldwide does less harm to public health than alcohol and cigarettes, but that the same is likely to hold true even if people consumed it on the same scale as these legal substances.

The report was to be the WHO's first report on cannabis for 15 years and was being eagerly awaited by doctors and specialists in drug abuse. However, it was ditched at the last minute following a long, intense dispute between WHO officials, the cannabis experts who drafted the report, and a group of external advisers believed to be from the US National Institute on Drug Abuse and the UN International Drug Control Program.

According to one member of the expert panel who drafted the report, it was feared by the advisers that the report would be used by groups campaigning to legalise marijuana.

(Source: New Scientist, 21 February 1998)

LUDICROUS ITEMS EMBARGOED IN IRAQ SANCTIONS

These are just a few of the items that have been, and still are, under embargo to Iraq since the Gulf War: aluminium foil, ambulances, ashtrays, axes, balls, baskets, bed lamps, belts, bicycles, books (all categories), candles, candlesticks, carpets, cars, chairs, coats, combs, computers, desks, detergents, dishes, dolls, doorknobs, doormats, envelopes, electric cords, eye-

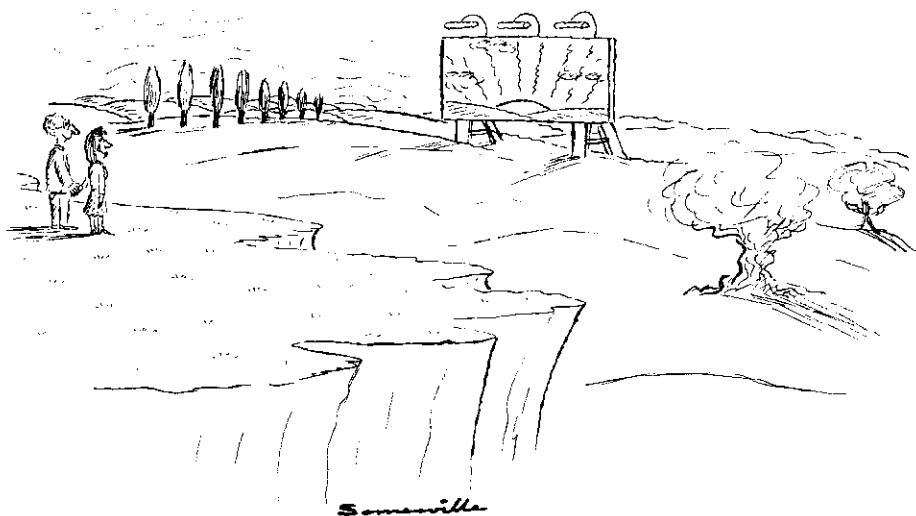

glasses, fans, filing cabinets, filters, forks, generators, hairpins, hammers, handkerchiefs, hats, hoes, hoses, jackets, kettles, light bulbs, magazines, matches, mirrors, mops, mugs, music CDs, musical instruments, napkins, oil lamps, pens, pots, razor blades, sandals, scales, screws, shirts, shoes, soap, sponges, stoves, sun hats, tables, telephones, timber, tin, tyre pumps, toys, TV sets, trash cans, tractors, trucks, venetian blinds, wallpaper, watches, water pumps, wheels, wood, wool and wrenches.

The sanctions, combined with radiation poisoning, bombed hospitals, fouled water supplies, etc., have reportedly resulted in the deaths of up to 1.7 million Iraqis, mostly children and the elderly, over the past seven years.

(Source: Green Left Weekly, 25 February & 4 March 1998)

US BANS INSPECTION OF ITS OWN CHEMICAL WEAPONRY

The United States, while preparing to attack Iraq in order to enforce weapons inspections, has drafted legislation on the inspection of its own chemical weapons arsenal in such a way that the President can refuse admission to international inspectors.

The legislation allows the President to pick and choose inspectors and to deny access to personnel from other countries without giving reasons, and with no legal redress against the decision.

In fact, the two sections containing the code of inspection over which the US threatened war against Iraq are both specifically omitted!

Ms Amy Smithson, who has waged a one-woman campaign for US ratification of

the international Chemical Weapons Convention, said: "We are in violation of the treaty, and it is so ironic that we are about to engage in hostilities against Iraq over the matter of weapons inspections because Saddam Hussein has registered the same exceptions as we have done."

(Sources: The Guardian, London; Sydney Morning Herald (SMH), 13 February 1998)

POPE HAS DOUBTS ABOUT 'NEW AGE' THINKING

The Pope is preparing an attack on "New Age" beliefs, an onslaught expected to be set out in an encyclical—a papal letter sent to all Roman Catholic bishops, and the most authoritative way in which he can make his ideas known.

His main objection is understood to be the concept of "systematic doubt", on the grounds that it precludes a belief in God that is rooted in certainty.

The Pope sees systematic doubt as the key to a system of beliefs which put man, not God, at the centre of the universe. He is thought to regard the New Age movement, with its emphasis on self-realisation, as a product of such thinking.

If, as reports in Rome suggest, a rare encyclical is issued, it will be a measure of the alarm that New Age thinking provokes at the highest levels in the Catholic Church.

(Source: SMH, 27 February 1998)

MOON WATER OFFERS HOT PROSPECTS FOR LUNAR BASE

Preliminary data collected from the Lunar Prospector, a US\$65 million robot craft launched in January, indicates that there is enough water frozen in the loose soil of the Moon to support a lunar

base or even a colony one day.

Initial estimates indicate that the Moon holds, in widely separated deposits, enough water to fill a lake 5.2 square kilometres by 10.5 metres deep.

"We think we are seeing between 10 million and 100 million tonnes of water," suggested Alan Binder, the NASA project's principal scientist.

(Source: SMH, 7 March 1998)

HOW TO PLUG LEAKS

Governments have always been plagued by leaks. Now Sun Microsystems of California has come up with a patent (EP 798 619) to identify the culprits.

The technique can identify the source of the document if it has been photocopied, or scanned with optical character recognition. It even works if the document has been retyped!

Each authorised recipient of the document is assigned a number in binary code. Sun's coding system then analyses the text and makes minor changes to each copy, such as leaving out a comma. These changes incorporate the unique code in the text without altering the meaning.

If someone leaks a copy, Sun's decoder compares the leaked document with its master, logs the differences and works out which of the authorised copies has been leaked.

(Source: New Scientist, 10 January 1998)

MMR VACCINE LINKED TO AUTISM AND BOWEL DISORDER

British doctors have discovered that the MMR (measles, mumps, rubella) vaccination may be a trigger for autism.

The study, conducted at the Royal Free Hospital, Hampstead, north London, also found a link between the vaccine and inflammatory bowel disease. It showed that out of 12 children who had previously been diagnosed normal, all developed an intestinal disorder and nine developed autism. According to GPs involved in the study, eight of the children developed changes in health and behaviour within six days of being vaccinated.

In a study of another group of children, 46 out of 48 experienced bowel and behavioural problems within six days of being given the vaccine.

(Sources: Herald Sun, Melbourne, 28 February 1998; Weekly Telegraph, London, 4-10 March 1998)

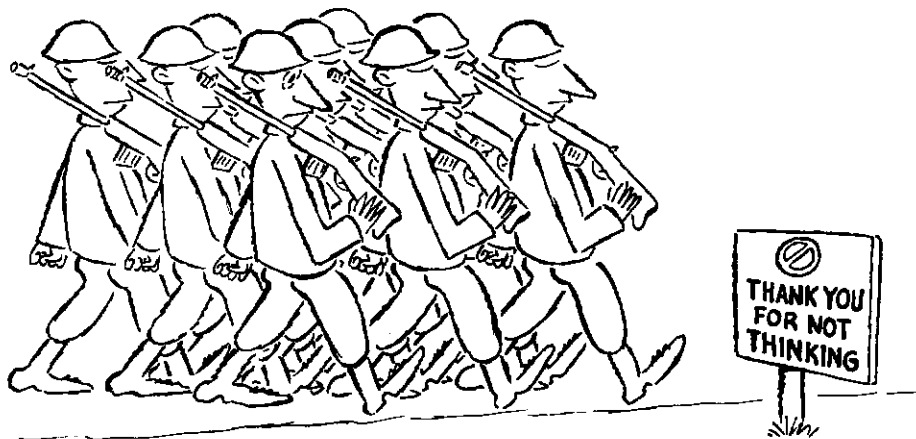

ENGLISH FREEMASONS IN THE LINE OF FIRE

The United Grand Lodge of England has been ordered to release the names of police officers allegedly involved in a series of corruption scandals.

The Lodge was given 14 days to comply with the request by the Commons Home Affairs Select Committee or face being arraigned before the House for contempt of Parliament.

The move came after MPs lost patience with Commander Michael Higham, Grand Secretary of the Freemasonry movement, when he repeatedly refused to provide information.

Commander Higham insisted that unless specific allegations were made he could not identify the men. They are among 169 serving and former policemen who were either members of the disbanded West Midlands Serious Crimes Squad or were involved in investigations into the Birmingham pub bombings and the Stalker affair.

In a further move, British Home Secretary Jack Straw has announced that in future, all judges, magistrates, Crown prosecutors, probation officers, prison staff and police officers will have to declare if they are members of the Lodge.

(Source: Weekly Telegraph, London, 25 February to 3 March 1998)

'WOMEN POWER' HALTS WORK ON INDIAN DAM PROJECT

On 3 October last year, after months of secret preparations, 10,000 Indian villagers, led by women and travelling in the dead of night while dodging police roadblocks, arrived at dawn at the huge, partly built dam on the Narmada River in Madhya Pradesh. Within minutes they had surprised the few guards and cut radio communications. By 6.30 am, one the largest sit-ins in Indian history had begun.

The 400-megawatt Maheshwar Dam is part of the multibillion-dollar Narmada Valley Development Project which involves plans for 30 big dams and over 3,000 small dams, and would displace more than 100,000 people.

Protests against the dams began more than 10 years ago, and thousands of women have said they are prepared to drown rather than move. This is the first time that all work has been stopped on one of the sites.

(Source: The Guardian Weekly, London, w/e 18 January 1998)

USDA PLANS WOULD OUTLAW GENUINE ORGANIC PRODUCE

by George Monbiot

Oprah Winfrey is an unlikely hero of the battle against big business. Yet the recent case she won, wherein she established her right to express an opinion about the merits of eating beefburgers, ranks with the McDonald's libel trial as one of the few serious setbacks suffered by the agro-industrial combines seeking to monopolise world food production.

She was sued by a syndicate of monster cattle ranchers under the surreal "food disparagement" laws, introduced in 14 American states to prevent people from questioning such practices as feeding bovine offal to cows.

These laws are a compelling demonstration of the lengths to which US legislators will go to defend the interests of corporations against the interests of citizens. We [in the UK] can only be thankful that there's an ocean between us and American plutocracy.

Our happy state won't last, however. Winfrey might have won her battle, but the war waged by an industry that can tolerate no dissent has only just begun. Its latest attempt to silence criticism and eliminate good practice is already well-advanced, and this time the consequences for Britain are just as profound as the consequences for America.

By 16 March, the US Department of Agriculture (USDA) will have closed its consultations on a new national standard for organic farming. Its proposals have horrified small farmers, consumer groups and animal welfare campaigners. If adopted and implemented, as protesters predict, the standards will outlaw genuine organic production all over the world.

The USDA would allow the labelling of fruit and vegetables in the United States as "organic" when they have been genetically engineered, irradiated, treated with additives and raised on contaminated sewage sludge. Under the new proposals, "organic" livestock can be housed in batteries, fed with the offal of other animals and injected with biotics. "Organic" produce, in the brave new world of American oligopoly, will be virtually indistinguishable from conventionally toxic food.

The solution would seem to be obvious: genuine organic producers should call their food something else. But the USDA is nothing if not far-sighted. The new proposals prohibit the setting of standards higher than those established by the department. In other words, farmers will be forbidden by law from producing and selling good food.

The next step, if these standards are adopted in the United States, is not hard to anticipate. American manufacturers will complain to their government that the European Union is erecting unfair barriers to trade by refusing to allow them to label the poisonous produce they sell here as organic food. The US Government will take the case to the World Trade Organization. The WTO will refer it to Codex Alimentarius, the food standards body dominated by corporate scientists. The Codex panel will decide that they cannot see any difference between American organic produce and European organic produce, and the WTO will threaten Europe with punitive sanctions if it continues to maintain the higher trading standard. This is precisely the means by which European consumers are being forced to eat beef and drink milk contaminated with injectable growth hormones.

There's no mystery about why US agribusiness wants its Washington subsidiary, the USDA, to set these new standards. The consumption of organic food is rising by 20 to 30 per cent a year, and in some countries is likely to become the dominant land-use. Organic farming is labour-intensive. It responds best to small-scale production, matched to the peculiarities of the land. Big business simply can't operate in an environment like this. There is no potential for hegemony. What it can't control, it must destroy.

The United States Government claims to be the champion of free trade, but it is, in truth, emphatically opposed to it. It seeks instead to exercise a coercive power of central control and legislative diktat—on a scale which makes the command economies of the old Soviet Union look like a village paper-round.

I've long believed that we should be allowed to vote in US elections, as their outcome affects us almost as much as it affects the Americans. British people now have a brief opportunity to do the next best thing and demand of the USDA that it drop this attempt to smother the seeds of rehabilitation. There are no second chances. Once the new standards come into force, our own government will be powerless to protect us from the consequences.

(Source: The Guardian, UK, 5 March 1998)

TOXIC SECRETS

Fluoride & the A-Bomb Program

During the ultra-secret Manhattan Project, a report was commissioned to assess the effect of fluoride on humans.

That report was classified "secret" for reasons of "national security".

**by Joel Griffiths and
Chris Bryson © 1997**

4 West 104th Street
New York, NY 10025, USA

Some 50 years after United States authorities began adding fluoride to public water supplies to reduce cavities in children's teeth, recently discovered declassified government documents are shedding new light on the roots of that still-controversial public health measure, revealing a surprising connection between the use of fluoride and the dawning of the nuclear age.

Today, two-thirds of US public drinking water is fluoridated. Many municipalities still resist the practice, disbelieving the government's assurances of safety.

Since the days of World War II when the US prevailed by building the world's first atomic bomb, the nation's public health leaders have maintained that low doses of fluoride are safe for people and good for children's teeth.

That safety verdict should now be re-examined in the light of hundreds of once-secret WWII-era documents obtained by these reporters [authors Griffiths and Bryson], including declassified papers of the Manhattan Project—the ultra-secret US military program that produced the atomic bomb.

Fluoride was the key chemical in atomic bomb production, according to the documents. Massive quantities—millions of tons—were essential for the manufacture of bomb-grade uranium and plutonium for nuclear weapons throughout the Cold War. One of the most toxic chemicals known, fluoride emerged as the leading chemical health hazard of the US atomic bomb program, both for workers and for nearby communities, the documents reveal.

Other revelations include:

- Much of the original proof that fluoride is safe for humans in low doses was generated by A-bomb program scientists who had been secretly ordered to provide "evidence useful in litigation" against defence contractors for fluoride injury to citizens. The first lawsuits against the American A-bomb program were not over radiation, but over fluoride damage, the documents show.

- Human studies were required. Bomb program researchers played a leading role in the design and implementation of the most extensive US study of the health effects of fluoridating public drinking water, conducted in Newburgh, New York, from 1945 to 1955. Then, in a classified operation code-named "Program F", they secretly gathered and analysed blood and tissue samples from Newburgh citizens with the cooperation of New York State Health Department personnel.

- The original, secret version (obtained by these reporters) of a study published by Program F scientists in the August 1948 *Journal of the American Dental Association*¹ shows that evidence of adverse health effects from fluoride was censored by the US Atomic Energy Commission (AEC)—considered the most powerful of Cold War agencies—for reasons of "national security".

- The bomb program's fluoride safety studies were conducted at the University of Rochester—site of one of the most notorious human radiation experiments of the Cold War, in which unsuspecting hospital patients were injected with toxic doses of radioactive plutonium. The fluoride studies were conducted with the same ethical mindset, in which "national security" was paramount.

EVIDENCE OF FLUORIDE'S ADVERSE HEALTH EFFECTS

The US Government's conflict of interest and its motive to prove fluoride safe in the furious debate over water fluoridation since the 1950s has only now been made clear to the general public, let alone to civilian researchers, health professionals and journalists.

The declassified documents resonate with a growing body of scientific evidence and a chorus of questions about the health effects of fluoride in the environment.

Human exposure to fluoride has mushroomed since World War II, due not only to fluoridated water and toothpaste but to environmental pollution by major industries, from aluminium to pesticides, where fluoride is a critical industrial chemical as well as a waste by-product.

The impact can be seen literally in the smiles of our children. Large numbers (up to 80 per cent in some cities) of young Americans now have dental fluorosis, the first visible sign of excessive fluoride exposure according to the US National Research Council. (The signs are whitish flecks or spots, particularly on the front teeth, or dark spots or stripes in more severe cases.)

Less known to the public is that fluoride also accumulates in bones. "The teeth are windows to what's happening in the bones," explained Paul Connett, Professor of Chemistry at St Lawrence University, New York, to these reporters. In recent years, paediatric bone specialists have expressed alarm about an increase in stress fractures among young people in the US. Connett and other scientists are concerned that fluoride—linked to bone damage in studies since the 1930s—may be a contributing factor.

The declassified documents add urgency: much of the original 'proof' that low-dose fluoride is safe for children's bones came from US bomb program scientists, according to this investigation.

Now, researchers who have reviewed these declassified documents fear that Cold War national security considerations may have prevented objective scientific evaluation of vital public health questions concerning fluoride.

"Information was buried," concludes Dr Phyllis Mullenix, former head of toxicology at Forsyth Dental Center in Boston and now a critic of fluoridation. Animal studies which Mullenix and co-workers conducted at Forsyth in the early 1990s indicated that fluoride was a powerful central nervous system (CNS) toxin and might adversely affect human brain functioning even at low doses. (New epidemiological evidence from China adds support, showing a correlation between low-dose fluoride exposure and diminished IQ in children.) Mullenix's results were published in 1995 in a reputable peer-reviewed scientific journal.²

During her investigation, Mullenix was astonished to discover there had been virtually no previous US studies of fluoride's effects on the human brain. Then, her application for a grant to continue her CNS research was turned down by the US National Institutes of Health (NIH), when an NIH panel flatly told her that "fluoride does not have central nervous system effects".

Declassified documents of the US atomic bomb program indicate otherwise. A Manhattan Project memorandum of 29 April 1944 states: "Clinical evidence suggests that uranium hexafluoride may have a rather marked central nervous system effect... It seems most likely that the F [code for fluoride] component rather than the T [code for uranium] is the causative factor." The memo, from a captain in the medical corps, is stamped SECRET and is addressed to Colonel Stafford Warren, head of the Manhattan Project's Medical Section. Colonel Warren is asked to approve a program of animal research on CNS effects. "Since work with

these compounds is essential, it will be necessary to know in advance what mental effects may occur after exposure... This is important not only to protect a given individual, but also to prevent a confused workman from injuring others by improperly performing his duties."

On the same day, Colonel Warren approved the CNS research program. This was in 1944, at the height of World War II and the US nation's race to build the world's first atomic bomb.

For research on fluoride's CNS effects to be approved at such a momentous time, the supporting evidence set forth in the proposal forwarded along with the memo must have been persuasive. The proposal, however, is missing from the files at the US National Archives. "If you find the memos but the document they refer to is missing, it's probably still classified," said Charles Reeves, chief librarian at the Atlanta branch of the US National Archives and Records Administration where the memos were found. Similarly, no results of the Manhattan Project's fluoride CNS research could be found in the files.

After reviewing the memos, Mullenix declared herself "flabbergasted". "How could I be told by NIH that fluoride has no central nervous system effects, when these documents were sitting there all the time?" She reasons that the Manhattan Project did do fluoride CNS studies: "That kind of warning, that fluoride workers might be a danger to the bomb program by improperly performing their duties—I can't imagine that would be ignored." But she suggests that the results were buried because of the difficult legal and public relations problems they might create for the government.

The author of the 1944 CNS research proposal attached to the 29 April memo was Dr Harold C. Hodge—at the time, chief of fluoride toxicology studies for the University of Rochester division of the Manhattan Project.

Nearly 50 years later at the Forsyth Dental Center in Boston, Dr Mullenix was introduced to a gently ambling elderly man, brought in to serve as a consultant on her CNS research. This man was Harold C. Hodge. By then, Hodge had achieved status emeritus as a world authority on fluoride safety. "But even though he was supposed to be helping me," said Mullenix, "he never once mentioned the CNS work he had done for the Manhattan Project."

The "black hole" in fluoride CNS research since the days of the Manhattan Project is unacceptable to Mullenix who refuses to abandon the issue. "There is so much fluoride exposure now, and we simply do not know what it is doing. You can't just walk away from this."

Dr Antonio Noronha, an NIH scientific review advisor familiar with Dr Mullenix's grant request, told us that her proposal was rejected by a scientific peer-review group. He termed her claim of institutional bias against fluoride CNS research "far-fetched". He then added: "We strive very hard at NIH to make sure politics does not enter the picture."¹

THE NEW JERSEY FLUORIDE POLLUTION INCIDENT

The documentary trail begins at the height of World War II, in 1944, when a severe pollution incident occurred downwind of the E.I. DuPont de Nemours Company chemical factory in Deepwater, New Jersey. The factory was then producing millions of pounds of fluoride for the Manhattan Project whose scientists

The declassified documents resonate with a growing body of scientific evidence and a chorus of questions about the health effects of fluoride in the environment.

were racing to produce the world's first atomic bomb.

The farms downwind in Gloucester and Salem counties were famous for their high-quality produce. Their peaches went directly to the Waldorf Astoria Hotel in New York City; their tomatoes were bought up by Campbell's Soup.

But in the summer of 1944 the farmers began reporting that their crops were blighted: "Something is burning up the peach crops around here." They said that poultry died after an all-night thunderstorm, and that farm workers who ate produce they'd picked would sometimes vomit all night and into the next day.

"I remember our horses looked sick and were too stiff to work," Mildred Giordano, a teenager at the time, told these reporters. Some cows were so crippled that they could not stand up; they could only graze by crawling on their bellies.

The account was confirmed in taped interviews with Philip Sadtler (shortly before he died), of Sadtler Laboratories of Philadelphia, one of the nation's oldest chemical consulting firms. Sadtler had personally conducted the initial investigation of the damage.

Although the farmers did not know it, the attention of the Manhattan Project and the federal government was riveted on the New Jersey incident, according to once-secret documents obtained by these reporters.

A memo, dated 27 August 1945, from Manhattan Project chief Major-General Leslie R. Groves to the Commanding General of Army Service Forces at the Pentagon, concerns the investigation of crop damage at Lower Penns Neck, New Jersey. It states: "At the request of the Secretary of War, the Department of Agriculture has agreed to cooperate in investigating complaints of crop damage attributed...to fumes from a plant operated in connection with the Manhattan Project."

After the war's end, Dr Harold C. Hodge, the Manhattan Project's chief of fluoride toxicology studies, worriedly wrote in a secret memo (1 March 1946) to his boss, Colonel Stafford L. Warren, chief of the Medical Section, about "problems associated with the question of fluoride contamination of the atmosphere in a certain section of New Jersey".

"There seem to be four distinct (though related) problems:

- "1. A question of injury of the peach crop in 1944.
- "2. A report of extraordinary fluoride content of vegetables grown in this area.
- "3. A report of abnormally high fluoride content in the blood of human individuals residing in this area.
- "4. A report raising the question of serious poisoning of horses and cattle in this area."

FLUORIDE DAMAGE: THE FIRST LAWSUITS

The New Jersey farmers waited until the war was over before suing DuPont and the Manhattan Project for fluoride damage—reportedly the first lawsuits against the US atomic bomb program. Although seemingly trivial, the lawsuits shook the government, the secret documents reveal.

Under the personal direction of Major-General Groves, secret

meetings were convened in Washington, with compulsory attendance by scores of scientists and officials from the US War Department, the Manhattan Project, the Food and Drug Administration, the Agriculture and Justice departments, the US Army's Chemical Warfare Service and Edgewood Arsenal, the Bureau of Standards, as well as lawyers from DuPont. Declassified memos of the meetings reveal a secret mobilisation of the full forces of the government to defeat the New Jersey farmers.

In a memo (2 May 1946) copied to General Groves, Manhattan Project Lt Colonel Cooper B. Rhodes notes that these agencies "are making scientific investigations to obtain evidence which may be used to protect the interest of the Government at the trial of the suits brought by owners of peach orchards in...New Jersey".

Regarding these lawsuits, General Groves wrote to the Chairman of the Senate Special Committee on Atomic Energy in a memo of 28 February 1946, advising that "the Department of Justice is cooperating in the defense of these suits".

Why the national security emergency over a few lawsuits by New Jersey farmers? In 1946 the United States began full-scale production of atomic bombs. No other nation had yet tested a nuclear weapon, and the A-bomb was seen as crucial for US leadership of the postwar world. The New Jersey fluoride lawsuits were a serious roadblock to that strategy. "The specter of endless lawsuits haunted the military," wrote Lansing Lamont in *Day of Trinity*, his acclaimed book about the first atomic bomb test.³

"If the farmers won, it would open the door to further suits which might impede the bomb program's ability to use fluoride," commented Jacqueline Kittrell, a Tennessee public interest lawyer who examined the declassified fluoride documents. (Kittrell specialises in nuclear-related litigation and has represented plaintiffs in several human radiation experiment cases.) "The reports of human injury were especially threatening because of the potential for enormous settlements—not to mention the PR problem," she added.

Indeed, DuPont was particularly concerned about the "possible psychological reaction" to the New Jersey pol-

lution incident, according to a secret Manhattan Project memo of 1 March 1946. Facing a threat from the Food and Drug Administration (FDA) to embargo the region's produce because of "high fluoride content", DuPont dispatched its lawyers to the FDA offices in Washington, DC, where an agitated meeting ensued. According to a memo sent next day to General Groves, DuPont's lawyer argued that "in view of the pending suits...any action by the Food and Drug Administration...would have a serious effect on the DuPont Company and would create a bad public relations situation". After the meeting adjourned, Manhattan Project Captain John Davies approached the FDA's Food Division chief and "impressed upon Dr White the substantial interest which the Government had in claims which might arise as a result of action which might be taken by the Food and Drug Administration".

There was no embargo. Instead, according to General Groves' memo of 27 August 1946, new tests for fluoride in the New

The New Jersey farmers waited until the war was over before suing DuPont and the Manhattan Project for fluoride damage—reportedly the first lawsuits against the US atomic bomb program.

Although seemingly trivial, the lawsuits shook the government, the secret documents reveal.

Jersey area were to be conducted not by the Department of Agriculture but by the US Army's Chemical Warfare Service (CWS)—because "work done by the Chemical Warfare Service would carry the greatest weight as evidence if...lawsuits are started by the complainants".

Meanwhile, the public relations problem remained unresolved: local citizens were in a panic about fluoride. The farmers' spokesman, Willard B. Kille, was personally invited to dine with General Groves (then known as "the man who built the atomic bomb") at his office at the War Department on 26 March 1946. Although diagnosed by his doctor as having fluoride poisoning, Kille departed the luncheon convinced of the government's good faith. Next day he wrote to the general, expressing his wish that the other farmers could have been present so that "they too could come away with the feeling that their interests in this particular matter were being safeguarded by men of the very highest type whose integrity they could not question".

A broader solution to the public relations problem was suggested by Manhattan Project chief fluoride toxicologist Harold C. Hodge in a second secret memo (1 May 1946) to Medical Section chief Colonel Warren: "Would there be any use in making attempts to counteract the local fear of fluoride on the part of residents of Salem and Gloucester counties through lectures on F toxicology and perhaps the usefulness of F in tooth health?" Such lectures were indeed given, not only to New Jersey citizens but to the rest of the nation throughout the Cold War.

The New Jersey farmers' lawsuits were ultimately stymied by the government's refusal to reveal the key piece of information that would have settled the case: how much fluoride DuPont had vented into the atmosphere during the war. "Disclosure would be injurious to the military security of the United States," Manhattan Project Major C. A. Taney, Jr, had written in a memo soon after the war's end (24 September 1945).

The farmers were pacified with token financial settlements, according to interviews with descendants still living in the area.

"All we knew is that DuPont released some chemical that burned up all the peach trees around here," recalled Angelo Giordano whose father James was one of the original plaintiffs. "The trees were no good after that, so we had to give up on the peaches." Their horses and cows acted and walked stiffly, recalled his sister Mildred. "Could any of that have been the fluoride?" she asked. (The symptoms she detailed are cardinal signs of fluoride toxicity, according to veterinary toxicologists.) The

Giordano family has also been plagued by bone and joint problems, Mildred added. Recalling the settlement received by the family, Angelo Giordano told these reporters that his father said he "got about \$200".

The farmers were stonewalled in their search for information about fluoride's effects on their health, and their complaints have long since been forgotten. But they unknowingly left their imprint on history: their complaints of injury to their health reverberated through the corridors of power in Washington and triggered intensive, secret, bomb program research on the health effects of fluoride.

"PROGRAM F": SECRET FLUORIDE RESEARCH

A secret memo (2 May 1946) to General Groves from Manhattan Project Lt Colonel Rhodes states: "Because of complaints that animals and humans have been injured by hydrogen fluoride fumes in [the New Jersey] area, although there are no pending suits involving such claims, the University of Rochester is conducting experiments to determine the toxic effect of fluoride."

Much of the proof of fluoride's alleged safety in low doses rests on the postwar work done at the University of Rochester in anticipation of lawsuits against the bomb program for human injury.

For the top-secret Manhattan Project to delegate fluoride safety studies to the University of Rochester was not surprising. During WWII the US Federal Government became involved for the first time in large-scale funding of scientific research at government-owned labs and private colleges. Those early spending priorities were shaped by the nation's often-secret military needs.

The prestigious upstate New York college in particular had housed a key wartime division of the Manhattan Project to study the health effects of the new "special materials" such as uranium, plutonium, beryllium and fluoride which were being used in making the atomic bomb. That work continued after the war, with millions of dollars flowing from the Manhattan Project and its successor organisation, the Atomic Energy Commission (AEC). (Indeed, the bomb left an indelible imprint on all of US science in the late 1940s and 1950s. Up to 90 per cent of all federal funds for university research came from either the Department of Defense or the AEC in this period, according to Noam Chomsky in his 1997 book, *The Cold War and the University*.)

The University of Rochester Medical School became a revolving door for senior bomb-program scientists. The postwar faculty included Stafford Warren, the top medical officer of the Manhattan Project, and Harold C. Hodge, chief of fluoride research for the bomb program.

But this marriage of military secrecy and medical science bore deformed offspring. The University of Rochester's classified fluoride studies, code-named "Program F", were started during the war and continued up until the early 1950s. They were conducted at its Atomic Energy Project (AEP), a top-secret facility funded by the AEC and housed at Strong Memorial Hospital. It was there that one of the most notorious human radiation experiments of the Cold War took place, in which unsuspecting hospital patients were injected with toxic doses of radioactive plutonium. Revelation of this experiment—in

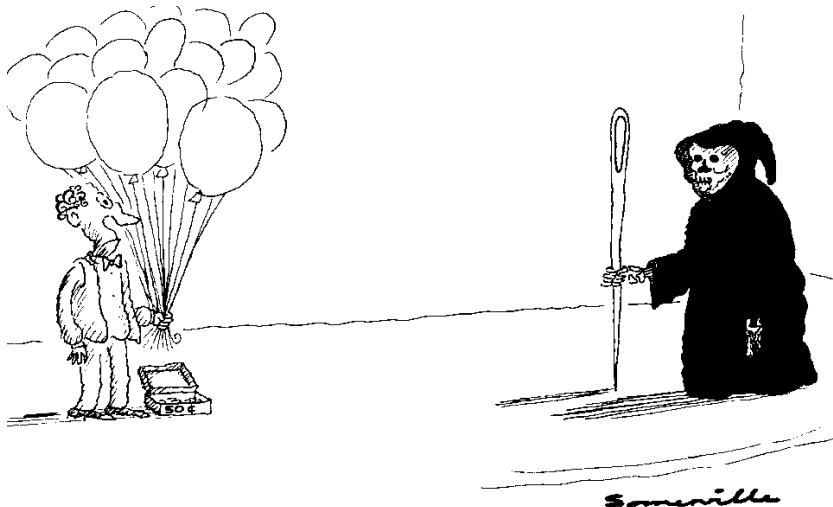

a Pulitzer Prize-winning account by Eileen Welsome—led to a 1995 US presidential investigation and a multimillion-dollar cash settlement for victims.

Program F was not about children's teeth. It grew directly out of litigation against the bomb program, and its main purpose was to furnish scientific ammunition which the government and its nuclear contractors could use to defeat lawsuits for human injury. Program F's director was none other than Dr Harold C. Hodge—who led the Manhattan Project investigation of alleged human injury in the New Jersey fluoride pollution incident.

Program F's purpose is spelled out in a classified 1948 report. It reads: "To supply evidence useful in the litigation arising from an alleged loss of a fruit crop several years ago, a number of problems have been opened. Since excessive blood-fluoride levels were reported in human residents of the same area, our principal effort has been devoted to describing the relationship of blood fluorides to toxic effects."

The litigation referred to and the claims of human injury were of course against the bomb program and its contractors. Thus the purpose of Program F was to obtain evidence useful in litigation against the bomb program. The research was being conducted by the defendants.

The potential conflict of interest is clear. If lower dose ranges were found hazardous by Program F, this might have opened the bomb program and its contractors to public outcry and lawsuits for injury to human health.

Lawyer Jacqueline Kittrell commented further: "This and other documents indicate that the University of Rochester's fluoride research grew out of the New Jersey lawsuits and was performed in anticipation of lawsuits against the bomb program for human injury. Studies undertaken for litigation purposes by the defendants would not be considered scientifically acceptable today because of their inherent bias to prove the chemical safe."

Unfortunately, much of the proof of fluoride's safety rests on the work performed by Program F scientists at the University of Rochester. During the postwar period, that university emerged as the leading academic centre for establishing the safety of fluoride as well as its effectiveness in reducing tooth decay, according to Rochester Dental School spokesperson William H. Bowen, MD. The key figure in this research, Bowen said, was Dr Harold C. Hodge—who also became a leading national proponent of fluoridating public drinking water.

THE A-BOMB AND WATER FLUORIDATION

Program F's interest in water fluoridation was not just "to counteract the local fear of fluoride on the part of residents", as Hodge had earlier written to Colonel Warren. The bomb program required human studies of fluoride's effects, just as it needed human studies of plutonium's effects. Adding fluoride to public water supplies provided one opportunity.

Bomb-program scientists played a prominent, if unpublicised, role in the nation's first-planned water fluoridation experiment in Newburgh, New York. The Newburgh Demonstration Project is considered the most extensive study of the health effects of fluoridation, supplying much of the evidence that low doses are

allegedly safe for children's bones and good for their teeth.

Planning began in 1943 with the appointment of a special New York State Health Department committee to study the advisability of adding fluoride to Newburgh's drinking water. The chairman of the committee was, again, Dr Harold C. Hodge, then chief of fluoride toxicity studies for the Manhattan Project. Subsequent members of the committee included Henry L. Barnett, a captain in the Project's Medical Section, and John W. Fertig, in 1944 with the Office of Scientific Research and Development—the super-secret Pentagon group which sired the Manhattan Project. Their military affiliations were kept secret. Hodge was described as a pharmacologist, Barnett as a paediatrician. Placed in charge of the Newburgh project was David B. Ast, chief dental officer of the New York State Health Department. Ast had participated in a key secret wartime conference on fluoride, held by the Manhattan Project in January 1944, and later worked with Dr Hodge on the Project's investigation of human injury in the New Jersey incident, according to once-secret memos.

The committee recommended that Newburgh be fluoridated. It selected the types of medical studies to be done, and it also "provided expert guidance" for the duration of the experiment.

The key question to be answered was: "Are there any cumulative effects, beneficial or otherwise, on tissues and organs other than the teeth, of long-continued ingestion of such small concentrations?" According to the declassified documents, this was also key information sought by the bomb program. In fact, the program would require "long-continued" exposure of workers and communities to fluoride throughout the Cold War.

In May 1945, Newburgh's water was fluoridated, and over the next 10 years its residents were studied by the New York State Health Department.

In tandem, Program F conducted its own secret studies, focusing on the amounts of fluoride Newburgh citizens retained in their blood and tissues—information called for by the bomb program in connection with litigation. "Possible toxic effects of fluoride were in the forefront of consideration," the advisory committee stated. Health department personnel cooperated, shipping blood and placenta samples to the Program F team at the University of Rochester. The samples were collected by Dr David B. Overton, the department's chief of paediatric studies at Newburgh.

The final report of the Newburgh Demonstration Project, published in 1956 in the *Journal of the American Dental Association*,⁵ concluded that "small concentrations" of fluoride were safe for US citizens. The biological proof, "based on work performed...at the University of Rochester Atomic Energy Project", was delivered by Dr Hodge.

Today, news that scientists from the A-bomb program secretly shaped and guided the Newburgh fluoridation experiment and studied the citizens' blood and tissue samples is greeted with incredulity.

"I'm shocked...beyond words," said present-day Newburgh Mayor Audrey Carey, commenting on these reporters' findings. "It reminds me of the Tuskegee experiment that was done on syphilis patients down in Alabama."

Today, news that scientists from the A-bomb program secretly shaped and guided the Newburgh fluoridation experiment and studied the citizens' blood and tissue samples is greeted with incredulity.

As a child in the early 1950s, Mayor Carey was taken to the old Newburgh firehouse on Broadway which housed the public health clinic. There, doctors from the Newburgh fluoridation project studied her teeth, and a peculiar fusion of two fingerbones on her left hand which she's had since birth. (Carey said that her granddaughter has white dental-fluorosis marks on her front teeth.)

Mayor Carey wants answers from the government about the secret history of fluoride and the Newburgh fluoridation experiment. "I absolutely want to pursue it," she said. "It is appalling to do any kind of experimentation and study without people's knowledge and permission."

When contacted by these reporters, the now 95-year-old David B. Ast, former director of the Newburgh experiment, said he was unaware that Manhattan Project scientists were involved. "If I had known, I would have been certainly investigating why, and what the connection was," he said. Did he know that blood and placenta samples from Newburgh were being sent to bomb-program researchers at the University of Rochester? "I was not aware of it," Ast replied. Did he recall participating in the Manhattan Project's secret wartime conference on fluoride in January 1944, or going to New Jersey with Dr Hodge to investigate human injury in the DuPont case, as secret memos state? He told these reporters he had no recollection of any such events.

Bob Loeb, a spokesperson for the University of Rochester Medical Center, confirmed that blood and tissue samples from Newburgh had been tested by the University's Dr Hodge. On the ethics of secretly studying US citizens to obtain information useful in litigation against the A-bomb program, he said: "That's a question we cannot answer." He referred inquiries to the US Department of Energy (DOE), successor to the Atomic Energy Commission.

Jayne Brady, a spokesperson for the Department of Energy in Washington confirmed that a review of DOE files indicated that a "significant reason" for fluoride experiments conducted at the University of Rochester after the war was "impending litigation between the DuPont company and residents of New Jersey areas". However, she added: "DOE has found no documents to indicate that fluoride research was done to protect the Manhattan Project or its contractors from lawsuits."

On Manhattan Project involvement in Newburgh, Brady stated: "Nothing that we have suggests that the DOE or predecessor agencies—especially the Manhattan Project—authorised fluoride experiments to be performed on children in the 1940s."

When told that these reporters have several documents that directly tie the AEP—the Manhattan Project's successor agency at the University of Rochester—to the Newburgh experiment, DOE spokesperson Brady later conceded her study was confined to "the available universe" of documents.

Two days later, Brady faxed a statement for clarification. "My search only involved the documents that we collected as part of our human radiation experiments project; fluoride was not part of our research effort."

"Most significantly," the statement continued, "relevant documents may be in a classified collection at the DOE Oak Ridge National Laboratory, known as the Records Holding Task Group. This collection consists entirely of classified documents removed from other files for the purpose of classified document account-

ability many years ago [and was] a rich source of documents for the human radiation experiments projects."

SUPPRESSION OF ADVERSE HEALTH FINDINGS

The crucial question arising from the investigation is whether adverse health findings from Newburgh and other bomb-program fluoride studies were suppressed. All AEC-funded studies had to be declassified before publication in civilian medical and dental journals. Where are the original classified versions?

The transcript of one of the major secret scientific conferences of World War II—on "fluoride metabolism"—is missing from the files of the US National Archives and is "probably still classified", according to the librarian. Participants in the January 1944 conference included key figures who promoted the safety of fluoride and water fluoridation to the public after the war: Harold Hodge of the Manhattan Project, David B. Ast of the Newburgh Demonstration Project, and US Public Health Service dentist H. Trendley Dean, popularly known as "the father of fluoridation".

A WWII Manhattan Project classified report (25 July 1944) on water fluoridation is missing from the files of the University of Rochester Atomic Energy Project, the US National Archives, and the Nuclear Repository at the University of Tennessee, Knoxville. The next four numerically consecutive documents are also missing, while the remainder of the "M-1500 series" is present.

"Either those documents are still classified, or they've been 'disappeared' by the government," said Clifford Honicker, Executive Director of the American Environmental Health Studies Project in Knoxville, Tennessee, which provided key evidence in the public exposure and prosecution of US human radiation experiments.

Seven pages have been cut out of a 1947 Rochester bomb project notebook entitled "DuPont Litigation". "Most unusual," commented the medical school's chief archivist,

Chris Hoolihan.

Similarly, Freedom of Information Act (FOIA) requests lodged by these reporters over a year ago with the DOE for hundreds of classified fluoride reports have failed to dislodge any. "We're behind," explained Amy Rothrock, chief FOIA officer at Oak Ridge National Laboratories.

So, has information been suppressed? These reporters made what appears to be the first discovery of the original classified version of a fluoride safety study by bomb program scientists. A censored version of this study was later published in the August 1948 *Journal of the American Dental Association*.⁶ Comparison of the secret version with the published version indicates that the US AEC did censor damaging information on fluoride—to the point of tragicomedy. This was a study of the dental and physical health of workers in a factory producing fluoride for the A-bomb program; it was conducted by a team of dentists from the Manhattan Project.

- The secret version reports that most of the men had no teeth left. The published version reports only that the men had fewer cavities.
- The secret version says the men had to wear rubber boots because the fluoride fumes disintegrated the nails in their shoes.

The secret version reports that most of the men had no teeth left.

The published version reports only that the men had fewer cavities.

Continued on page 85

The Hidden History of Jesus and the Holy Grail

The early Christian Church leaders adopted scriptures and teachings that would deliberately obscure the truth about the royal bloodline of Jesus.

Part 2

From a lecture presented by
Sir Laurence Gardner, Kt St Gm, KCD
Author of *Bloodline of the Holy Grail*
at The Ranch, Yelm, Washington, USA
30 April 1997

Videotape transcribed by Ruth Parnell
Additional editing by Sir Laurence Gardner

It was not until the early seventeenth century that the first acceptable English language Bible translation was made—for the Scots King James VI (Stuart), James I of England. This was the Authorized Version, upon which the majority of subsequent English-language Bibles have been based. But even this was not a direct translation from anything; it was mostly translated from the Greek, partly from the Latin, and to some extent from the works of others who'd made other illegitimate translations before.

In their rendering of the New Testament, King James' translators endeavoured to appease both the Protestants and the Catholics. This was the only way to produce a generally acceptable text, but their attempt to appease was not entirely successful. The Catholics thought the translators were siding with the Protestants and tried to blow up King James in the Houses of Parliament, and the Protestants said the translators were in league with the Catholics.

Anyway, the Bible survived but the translators tried as well for something called "political correctness". We know about it today; it applied then. Good examples of this are found in many instances—one in particular where the direct translation referred to a group of people called "heavenly soldiers". They didn't like this very much, so it's actually crossed out, and underneath it says "heavenly army". But somebody else came along and said, "No, this is still not good enough; it denotes an armed unit here; this is not politically correct," and so it was crossed out *again*, and they resurrected an old word that had not been written in the English language for centuries. They called it "the heavenly *host*". Nobody knows what the heavenly host is. In fact it's quite astounding how many obscure, old and obsolete words were brought back into use to provide political correctness for the King James Bible, but which nobody could understand. At the same time, William Shakespeare was doing likewise in his plays.

If we look at the reference books that existed *prior* to James and Shakespeare and at those that existed just *after* James and Shakespeare, we see that the English-language vocabulary was increased by more than fifty per cent as a result of words invented or brought back from obscurity by the writers of the era. The problem was that nobody, let alone the dictionary compilers, knew what most of these words meant. But they had somehow to be defined, and "heavenly host" emerged, quite ambiguously, as "a heavenly lot of people"!

So although eminently poetic, the language of the Authorized English Bible is quite unlike any language ever spoken by anyone in England or anywhere else. It bears no relation to the Greek or Latin from which it was translated. It was certainly not the language spoken by God, as some priests once told me. But from this approved canonical interpretation, all other English language Bibles have emerged in their various forms. Despite that, for all of its faults, despite its beautiful verse patterns and the new words, it still remains the closest of all English language translations from the original Greek manuscripts. All other versions, the Standard versions, the New versions, the Revised versions, the Modern English versions, have been significantly corrupted and they're quite unsuitable for serious study by anyone because they have their own specific agenda.

We can cite an extreme version of how this works in practice. We can look at a Bible currently issued today in Pacific Papua New Guinea where there are tribes who experience familiarity on a daily basis with no other animal but the pig. In the current edition of their Bible, every animal mentioned in the text, whether originally an ox, lion, ass, sheep or whatever, is now a pig! Even Jesus, the traditional "Lamb of God", in this Bible is "the Pig of God"!

So, to facilitate the best possible trust in the Gospels, we must go back to the original

Greek manuscripts with their often-used Hebrew and Aramaic words and phrases. And in so doing we discover that, just as with the Nativity story, a good deal of relevant content has been misrepresented, misunderstood, mistranslated or simply just lost in the telling. Sometimes this has happened because original words have no direct counterpart in other languages.

We've all been taught that Jesus' father Joseph was a carpenter. "Why not? It says so in the Gospels." But it didn't say that in the original Gospels. By the best translation, it actually said that Joseph was a Master of the Craft. The word "carpenter" was simply a translator's concept of a craftsman. Anyone associated with modern Freemasonry will recognise the term "the Craft". It's got nothing whatever to do with woodwork. The text simply denoted that Joseph was a masterly, learned and scholarly man.

Another example is the concept of the Virgin Birth. Our English-language Gospels tell us that Jesus' mother Mary was a virgin; they *keep* telling us that she was a virgin. Well, let's consider the word "virgin". We understand the word; it tells us that this was a woman with no experience of sexual union. But this was translated not from the Greek initially but from the Latin.

That was easy because the Latin called her *virgo*; Mary was a *virgo*. It didn't mean the same thing at all! *Virgo* in Latin meant nothing more than "a young woman". To have meant the same thing as "virgin" does to us today, the Latin would have been *virgo intacta*, that is to say, "a young woman intact".

Let's look back beyond the Latin text; let's see why they called her *virgo*, a young woman. Maybe they actually got something right which we've got wrong later on. We discover that the word translated to mean *virgo*, a young woman, was the old Hebrew word *almah* which meant "a young woman". It had no sexual connotation whatever. Had Mary actually been physically *virgo intacta*, the Hebrew word used would have been *bethula*, not *almah*.

So, have we been completely misguided by the Gospels? No; we've been misguided by the English language *translations* of the Gospels. We've also been misguided by a Church establishment that has done everything in its power to deny women any normal lifestyle in the Gospel story. The New Testament's key women are virgins or whores or sometimes widows—never everyday girlfriends, wives or mothers, and certainly not ever priestesses or holy sisters.

Notwithstanding that, the Gospels tell us time and time again that Jesus was descended from King David through his father Joseph. Even St Paul tells us this in his Epistle to the Hebrews. But we are taught that Jesus' father was a lowly carpenter and his mother was a virgin—neither of which descriptions can be found in any original text. So it follows that to get the best out of the Gospels we've really got to read them as they were written, not as we decide to interpret them according to modern language.

Precisely when the four main Gospels were written is uncertain. What we do know is that they were first published at various stages in the second half of the first century. They were unanimous initially in telling us that Jesus was a Nazarene. This is actually upheld in the Roman annals; and the first-century chronicles of the Jews and the Bible's Acts of the Apostles confirm that

Jesus' brother James and St Paul were leaders of the sect of the Nazarenes.

This definition of "Nazarene" is very important to the Grail story because it has been so often misrepresented to suggest that Jesus came from the town of Nazareth. For the past 400 years, English language Gospels have perpetuated the error by wrongly translating "Jesus the Nazarene" as "Jesus of Nazareth". There was no connection between Nazareth and the Nazarenes. In fact, the settlement at Nazareth was established in the AD 60s, thirty years or so *after* the Crucifixion. Nobody in Jesus' early life came from Nazareth—it was not there!

The Nazarenes were a liberal, Jewish sect opposed to the strict Hebrew regime of the Pharisees and Sadducees. The Nazarene culture and language were heavily influenced by the philosophers of ancient Greece, and their community supported the concept of equal opportunity for men and women. Documents of the time referred not to Nazareth but to the Nazarene society. Priestesses existed in equal opportunity with priests, but this was so different from what the male-dominated Hebrew society wanted and what the later, male-dominated Roman Church required.

It has to be remembered that Jesus was not a Christian: he was a Nazarene—a radical, westernised Jew. The Christian movement was founded by others in the wake of his own mission. The word "Christian" was first recorded and used in AD 44 in Antioch, Syria.

In the Arab world, the word used today, as then, to describe Jesus and his followers is *Nazara*. This is confirmed in the Muslim Koran: Jesus is *Nazara*; his followers are *Nazara*. The word means "Keepers" or "Guardians". The full definition is *Nazrie ha-Brit*, "Keepers of the

Covenant". In fact, the *Brit* aspect of that is the very root of the country name of Britain. *Brit-ain* means "Covenant-land".

In the time of Jesus the Nazarenes lived in Galilee, and in that mystical place which the Bible calls "the Wilderness". The Wilderness was actually a very defined place. It was essentially the land around the main settlement at Qumran which spread out to Mird and other places. It was where the Dead Sea Scrolls were produced—discovered at Qumran in 1948.

Somewhere after the Crucifixion, Peter and his friend Paul went off to Antioch, then on to Rome, and they began the movement that became Christianity. But as recorded in the other annals, Jesus, his brother James and the majority of the other apostles continued the Nazarene movement and progressed it into Europe. It became the Celtic Church. The Nazarene movement as a Church is documented within the Celtic Church records as being formally implemented as the Church of Jesus in AD 37, four years after the Crucifixion. The Roman Church was formed 300 years later, after Paul and Peter's Christians had been persecuted for three centuries.

Through many centuries the Nazarene-based Celtic Church movement was directly opposed therefore to the Church of Rome. The difference was a simple one: the Nazarene faith was based on the teachings of Jesus himself. The guts of the religion, the moral codes, the behavioural patterns, the social practices, the laws and justices related to Old Testament teaching but with a liberal message of equality in mind—*this* was the religion of Jesus. Roman Christianity is "Churchianity". It was not the message of

So, have we been completely misguided by the Gospels?

No; we've been misguided by the English-language *translations* of the Gospels.

Jesus that was important: this Church turned Jesus into the religion. In short, the Nazarene Church was the true social Church. The Roman Church was the Church of the Emperors and the Popes; this was the Imperial hybrid movement.

Apart from straightforward misunderstandings, misinterpretations and mistranslations, the canonical Gospels suffer from numerous purposeful amendments. Some original entries have been changed or deleted; other entries have been added to suit the Church's vested interest. Back in the fourth century when the texts were translated into Latin from their original Greek and Semitic tongues, the majority of these edits and amendments were made.

Even earlier, about AD 195—one thousand, eight hundred years ago—Bishop Clement of Alexandria made the first known amendment from the Gospel texts. He deleted a substantial section from the Gospel of Mark, written more than a hundred years before that time, and he justified his action in a letter. "For even if they should say something true, one who loves the Truth should not...agree with them... For not all true things are to be said to all men." Interesting. What he meant was that even at that very early stage there was already a discrepancy between what the Gospel writers had written and what the bishops wanted to teach.

Today, this section deleted by St Clement is still missing from the Gospel of Mark. But when Mark is compared with the Gospel that we know today, even *without* that section we find that today's Gospel is a good deal *longer* than the original! One of these additional sections comprises the whole of the Resurrection sequence; this amounts to twelve full verses at the end of Mark, chapter 16.

It's now known that everything told about the events after the Crucifixion was added by Church bishops or their scribes some time in the late fourth century. Although this is confirmed in the Vatican archives, it is difficult for most people to gain access—and even if they do, old Greek is very difficult to understand.

But what exactly was in this section of Mark that Clement saw fit to remove? It was the section that dealt with the raising of Lazarus. In the context of the original Mark text, however, Lazarus was portrayed in a state of excommunication: spiritual death by decree, not physical death. The account even had Lazarus and Jesus calling to each other before the tomb was opened. This defeated the bishops' desire to portray the raising of Lazarus as a spiritual miracle, not as a simple release from excommunication. More importantly, it set the scene for the story of the Crucifixion of Jesus himself, whose own subsequent raising from spiritual death was determined by the same three-day rule that applied to Lazarus.

Jesus was raised (released or resurrected) from death by decree on the statutory third day. In the case of Lazarus, however, Jesus flouted the rules by raising his friend *after* the three-day period of symbolic sickness. At that point, civil death would have become absolute in the eyes of the legal elders. Lazarus would have been wrapped in sacking and buried alive. His crime was that he had led a violent people's-revolt to safeguard the public water supply which had been diverted through a new Roman aqueduct in Jerusalem. But Jesus performed this release while not holding

any priestly entitlement to do so. What happened was that Herod-Antipas of Galilee compelled the High Priest of Jerusalem to relent in favour of Jesus—and this was regarded as an unprecedented miracle!

But there was more to the removed section of Mark, because in telling the story of Lazarus the Mark account made it perfectly clear that Jesus and Mary Magdalene were actually man and wife. The Lazarus story in John contains a rather strange sequence that has Martha coming from the Lazarus house to greet Jesus, whereas her sister, Mary Magdalene, remains inside until summoned by Jesus. But in contrast to this, the original Mark account said that Mary Magdalene actually came out of the house with Martha and was then chastised by the disciples and sent back indoors to await Jesus' instruction. This was a specific procedure of Judaic law, whereby a wife in ritual mourning was not allowed to emerge from the property until instructed by her husband.

There's a good deal of information outside the Bible to confirm that Jesus and Mary Magdalene were man and wife. But is there anything relevant in the Gospels today, anything that the editors missed that tells us the story? Well, there are some specific things and there are some ancillary things.

There are seven lists given in the Gospels of the women who

permanently seemed to follow Jesus around, and these include Jesus' mother; but in six of these seven lists the first name, even ahead of his mother, is Mary Magdalene. When one studies other lists of the period which relate to any form of hierarchical society, one notices that the "first lady" was always the first name listed. The term "First Lady" is used in America today. The first lady was the most senior; she was always named first—and as the Messianic Queen, Mary Magdalene would have been named first, as indeed she was.

But is the marriage defined in the Gospels? Well, it is. Many have suggested that the wedding at Cana was the marriage of Jesus and Mary Magdalene. This was not the wedding ceremony as such, although the marriage is detailed in the Gospels. The marriage is the quite separate anointings at Bethany. In Luke we have a first anointing by Mary of Jesus, two-and-a-half years before the second anointing. It doesn't occur to many people that they are different stories, but they are two-and-a-half years apart.

Readers of the first century would have been fully conversant with the two-part ritual of the sacred marriage of a dynastic heir. Jesus, as we know, was a "Messiah", which means quite simply an "Anointed One". In fact, all anointed senior priests and Davidic kings were Messiahs. Jesus was not unique. Although not an ordained priest, he gained his right to Messiah status by way of descent from King David and the kingly line, but he did not achieve that Messiah status until he was actually physically anointed by Mary Magdalene, in her capacity as a high priestess, shortly before the Crucifixion.

The word "Messiah" comes from the Hebrew verb "to anoint", which itself is derived from the Egyptian word *messeh*, "the holy crocodile". It was with the fat of the *messeh* that the Pharaoh's sister-brides anointed their husbands on marriage. The Egyptian custom sprang from kingly practice in old Mesopotamia.

In the Old Testament's Song of Solomon we hear again of the bridal anointing of the king. It is defined that the oil used in

Apart from straightforward misunderstandings, misinterpretations and mistranslations, the canonical Gospels suffer from numerous purposeful amendments.

Judah was the fragrant ointment spikenard, an expensive root oil from the Himalayas, and we learn that this anointing ritual was performed always while the husband/king sat at the table. In the New Testament, the anointing of Jesus by Mary Magdalene was indeed performed while he sat at the table, and with the bridal anointment of spikenard. Afterwards, Mary wiped his feet with her hair, and on the first occasion of the two-part marriage she wept. All of these things signify the marital anointing of a dynastic heir.

Other anointings of Messiahs, whether on coronation or admission to the senior priesthood, were always conducted by men, by the High Zadok or the High Priest. The oil used was olive oil, mixed with cinnamon and other spices; never, ever spikenard.

Spikenard was the express prerogative of a Messianic bride who had to be a Mary, a sister of a sacred order. Jesus' mother was a Mary; so, too, would his wife have been a Mary, by title at least if not by baptismal name. Some conventual orders still maintain the tradition by adding the title "Mary" to the baptismal names of their nuns: Sister Mary Theresa, Sister Mary Louise.

Messianic marriages were always conducted in two stages. The first stage, the anointing in Luke, was the legal commitment to wedlock. The second stage, the anointing in Matthew, Mark and John, was the cementing of the contract. And in Jesus and Mary's case, the second anointing at Bethany was of express significance. Here the Grail story begins, because, as explained in books of Jewish law at the time and by Flavius Josephus in *The Antiquities of the Jews*, the second part of this marriage ceremony was never conducted until the wife was three months pregnant.

Dynastic heirs such as Jesus were expressly required to perpetuate their lines. Marriage was essential, but the law had to protect them against marriage to women who proved barren or kept miscarrying, and this protection was provided by the three-month-pregnancy rule. Miscarriages would not often happen after that term, and once they got through that period it was considered safe enough to complete the marriage contract. When anointing her husband at this stage, the Messianic bride, in accordance with custom, was said to be anointing him for burial. This is confirmed in the Gospels. The bride would from that day carry a vial of spikenard around her neck, for the rest of her husband's life; she would use it again on his entombment.

It was for this very purpose that Mary Magdalene would have gone to the tomb, as she did on the Sabbath after the Crucifixion. Subsequent to the second Bethany anointing, the Gospels relate that Jesus said: "Wheresoever this Gospel shall be preached throughout the whole world, this also that she hath done shall be spoken of for a memorial of her."

In his famous rendering of the event, the Renaissance artist Fra Angelico actually depicted Jesus placing a crown on the head of Mary Magdalene. But despite the fact that Fra Angelico was a learned 15th-century Dominican friar, did the Christian Church authorities honour Mary Magdalene and speak of this act as a

memorial of her? No; they did not. They completely ignored Jesus' own directive and denounced Mary as a whore.

To the esoteric Church and the Knights Templars, however, Mary Magdalene was always regarded as a saint. She is still revered as such by many today, but the interesting part about this sainthood, when we think about Grail lore, is that Mary is listed as the patron saint of winegrowers, the guardian of the vine—the guardian of the Holy Grail, the guardian of the sacred bloodline.

There is much in the Gospels that we don't presume to be there because we are never encouraged to look beyond the superficial level. We've been aided greatly in this regard in recent years by the Dead Sea Scrolls and by the extraordinary research of Australian theologian Dr Barbara Thiering.

The Dead Sea Scrolls have opened up a whole new awareness of jargon; we have a whole new enlightenment here. They set down the community offices of the Messiah of Israel. They tell us about the council of twelve delegate apostles who were permanently appointed to preside over specific aspects of government and ritual. This leads to a greater awareness of the apostles themselves. We now know not only what their names were—we always knew that—but we can understand who they were, who their families were, what their duties and positions were.

We now understand from studying the Gospels that there is an allegory within them: the use of words that we don't understand today. We now know that baptismal priests were called "fishers"; we know that those who aided them by hauling the baptismal candidates into the boats in large nets were called "fishermen"; and we know that the baptismal candidates themselves were called "fishes". The apostles James and John were both ordained "fishers". The brothers Peter and Andrew were lay "fishermen", and Jesus promised them priesthood within the new ministry, saying "I will make you to become fishers of men".

We now know there was a particular jargon of the Gospel era, a jargon that would have been readily understood by anybody reading the Gospels in the first century and beyond. These jargonistic words have been lost to later interpretation. Today, for example, we call our theatre investors "angels" and our top entertainers "stars", but what would a reader from some distant culture in two thousand years' time make of "The angel went to talk to the stars"? The Gospels are full of these jargonistic words. "The poor", "the lepers", "the multitude", "the blind"—none of these was what we presume it to mean today. Definitions such as "clouds", "sheep", "fishes", "loaves" and a variety of others were all related, just like "stars", to people.

When the Gospels were written in the first century they were issued into a Roman-controlled environment. Their content had to be disguised against Roman scrutiny. The information was often political; it was coded, veiled. Where important sections appeared they were often heralded by the words, "This is for those with ears to hear"—for those who understand the code. It was no different to the coded information passed between members of

**Today, for example,
we call our theatre
investors "angels" and
our top entertainers
"stars", but what would
a reader from some
distant culture in
two thousand years'
time make of
"The angel went to talk
to the stars"?**

oppressed groups throughout history. There was a code found in documentation passed between the later Jews in Germany in the 1930s and 1940s.

Through our knowledge of this scribal cryptology we can now determine dates and locations with very great accuracy. We can uncover many of the hidden meanings in the Gospels to the extent that the miracles themselves take on a whole new context. In doing so, this does not in any way decry the fact that a man like Jesus, and, in fact, specifically Jesus, was obviously a very special person with enormously special powers, but the Gospels laid down certain stories which have since become described as "miracles". These were not put down because they were really miraculous supernatural events; they were put down because in the then-current political arena they were actually quite unprecedented actions which successfully flouted the law.

We now know other things. We now know why the Gospels are often not in agreement with each other. For example, Mark says that Jesus was crucified at the *third* hour, whereas John says he was crucified at the *sixth* hour. This does not, on the face of it, look too important, but, as we shall see, this three-hour time difference was crucial to the events that followed.

Let's look at the water and wine at Cana, following the story through what the Bible actually tells us, as against what we think we know. What was a very straightforward event is now dubbed with supernatural overtones. The Cana wedding, out of four Gospels, is described only in John. If it was so important to the Church as a miracle, why is it not in the other three Gospels? It does not say (as is so often said from pulpits): "They ran out of wine." It doesn't say that. It says: "When they wanted wine, the mother of Jesus said, 'They have no wine.'"

The Gospel tells us that the person in charge was the ruler of the feast. This specifically defines it not as a wedding ceremony as such, but a pre-wedding betrothal feast. The wine taken at betrothal feasts was only available to priests and celibate Jews, not to married men, novices or any others who were regarded as being unsanctified. They were allowed only water—a purification ritual, as stated in John.

When the time came for this ritual, Mary, clearly not happy about the discrimination and directing Jesus' attention to the unsanctified guests, said: "They have no wine." Having not yet been anointed to Messiah status, Jesus responded: "Mine hour is not yet come." At this, Mary forced the issue and Jesus then flouted convention, abandoning water altogether. Wine for everyone! The ruler of the feast made no comment whatsoever about any miracle; he simply expressed his amazement that the wine had turned up at that stage of the proceedings.

It's been suggested often that the wedding at Cana was Jesus' own wedding ceremony because he and his mother displayed a right of command that would not be associated with ordinary guests. However, this feast can be dated to the summer of AD 30, in the month equivalent to June. First weddings were always held in the month of Atonement (September), and betrothal feasts were held three months before that. In this instance, we find that the first marital anointing of Jesus by Mary Magdalene was at the Atonement of AD 30, three months after the Cana ceremony

which appears to have been their own betrothal feast.

The Gospels tell a story that although not always in agreement from Gospel to Gospel is actually followable outside the Bible. The accounts of Jesus' activities right up to the time of the Crucifixion can be found in various records of the era. In the official annals of Imperial Rome, the trial by Pilate and the Crucifixion are mentioned. We can determine precisely from this chronological diary of the Roman governors that the Crucifixion took place at the March Passover of AD 33. The Bethany second marriage anointing was in the week prior to that. We know that at that stage Mary Magdalene had to have been three months pregnant, by law—which means she should have given birth in September of AD 33. That, we'll come back to.

If the Gospels are read as they are written, Jesus appears as a liberating dynast, endeavouring to unite the people of the era against the oppression of the Roman Empire. Judaea at the time was just like France under German occupation in World War II. The authorities were controlled by the military occupational force; resistance movements were common.

Jesus was awaited, expected, and by the end of the story had become an anointed Messiah. In the first century *Antiquities of the Jews*, Jesus is called "a wise man", "a teacher" and "the King". There is nothing there about divinity.

While the Dead Sea Scrolls identify the Messiah of Israel as the Supreme Military Commander of Israel, it is no secret the apostles were armed. From the time of recruitment, Jesus checked that they all had swords. At the very end of the story, Peter drew his sword

against Malchus. Jesus said, "I come not to send peace but a sword."

Many of the high-ranking Jews in Jerusalem were quite content to hold positions of power backed by a foreign military regime. Apart from that, the Hebrew groups themselves were sectarian; they did not want to share their God Jehovah with anybody else, specifically unclean Gentiles. To the Pharisees and Sadducees, the Jews were God's chosen people: He belonged to them, they belonged to Him. But there were other Jews—there were the Nazarenes, there were the Essenes—who were influenced by a more liberal, western doctrine. In the event, Jesus' mission failed; the rift was insurmountable. Gentiles, in modern-day language, are simply the non-Jewish Arab races—and the rift is still there today.

The sentencing of Jesus was by the Roman Governor Pontius Pilate, but Jesus was actually condemned and excommunicated prior to that by the Sanhedrin Council. It was decided to contrive a punishment, whereby Jesus would be sentenced by the Roman Governor who was already trying other prisoners for leading insurrections against himself.

As confirmed by the Supreme Judge and Attorney-General of Israel even today, it was quite illegal for the Sanhedrin Council to sit at night or to sit and operate during the Passover, so the timing was perfect. They had an ideal opportunity, and a reason to say: "Sorry, we can't do this ourselves. You, the Roman Governor, have to do this."

As for Jesus' death on the Cross, it is perfectly plain this was spiritual death, not physical death, as determined by the three-day

While the Dead Sea Scrolls identify the Messiah of Israel as the Supreme Military Commander of Israel, it is no secret the apostles were armed. From the time of recruitment, Jesus checked that they all had swords.

rule that everybody in the first century reading this would have understood. In civil and legal terms, Jesus was already dead when he was placed on the Cross. He was denounced, scourged, prepared for death by decree. Today, we call this "excommunication". For three days Jesus would have been nominally sick, with absolute death coming on the fourth day. On that day he would be entombed, buried alive; but during the first three days he could be raised or resurrected. In fact, he *predicted* that he would.

Raisings and resurrections (apart from the fact that Jesus once flouted the rule, and that was a miracle!) could only be performed by the High Priest or by the Father of the Community. The High Priest at that time was Joseph Caiaphas, the very man who condemned Jesus; therefore the raising had to be performed by the patriarchal Father. There are Gospel accounts of Jesus talking to the Father from the Cross, culminating in "Father, into thy hands I commend my spirit", and at that time we know from the listings that the appointed Father was the Magian apostle Simon Zelotes.

We have been taught that Jesus' physical death was proved by the blood and water that flowed when he was pierced by the spear, but this has been very badly translated. The original word does not translate to "pierced"; it translates to "pricked" or to "scratched". This in turn was mistranslated into the Latin verb "to open", and into the English word "pierced".

They were not primitive times. They were times when there were doctors, medical men; there were even forms of hospital. And we can see that, just like today, the test for reflex action was scratching, prodding or pricking the skin with a sharp instrument.

I have in my possession a letter from a surgeon of the British Medical Council. It says: "Medically, the outflow of water is impossible to explain. Blood flowing from a stab wound is evidence of life, not death. It would take a large, gaping laceration for any drop of blood to flow from a dead body because there is no vascular action."

So let's look further; let's look at what the Gospels actually said. Joseph of Arimathea took down Jesus' body from the Cross. In fact, the word that was translated to the English word "body" was the Greek word *soma*, meaning "live body". The alternative word denoting "dead body" or "corpse" would have been *ptoma*.

Jesus very apparently survived, and this is explicitly maintained in other books. Even the Koran says that Jesus survived the Crucifixion.

During that Friday afternoon when Jesus was on the Cross, there was a three-hour-forward time change. Time was recorded then by sundials and by priests who marked the hours by a sequence of measured prayer sessions. In essence, there were daytime hours and there were night-time hours. Today we have a twenty-four-hour day. In John, Jesus said: "Are there not twelve hours in a day?" Yes, there were twelve hours in a day and there were twelve hours in the night, and daytime started at sunrise. From time to time the beginning of daytime changed; thus the beginning of night-time changed. In March, the beginning of daytime would have been somewhere round about six o'clock in the morning, as we know it.

We know that Joseph of Arimathea negotiated with Pontius Pilate to have Jesus removed from the Cross after a few hours of hanging. The Gospels don't actually agree on the sequence of

events here: some use the time *before* the time change; some use the time *after* the time change. But three hours disappeared from the day, to be replaced with three night-time hours. Daylight hours were substituted by hours of darkness. The land fell into darkness for three hours, we are told in the Gospels. Today we would simply, in a split second, add three night-time hours to the day.

But these three hours were the crux of every single event that followed, because the Hebrew lunarists made their change during the daytime. The solarists, of which the Essenes and the Magi were factions, did not make their change until midnight—which actually means that according to the Gospel that relates to Hebrew time, Jesus was crucified at the third hour; but in the other, solar time he was crucified at the sixth hour.

On that evening the Hebrews began their Sabbath at the old nine o'clock, but the Essenes and Magians still had three hours to go before the Sabbath. It was those three hours that enabled them

to work with, on and for Jesus, during a period of time in which nobody else was allowed to undertake any physical work whatsoever.

And so we come to probably one of the most misunderstood events of the Bible, and from there we'll move on, beyond the Bible period through history, to tell what happened concerning the birth of Jesus and Mary's child in September AD 33. One of the most misunderstood events

in the Bible is the Ascension, and in discussing it we will consider the births of Jesus' three children and their descendants.

Continued in the next issue of NEXUS...

In civil and legal terms, Jesus was already dead when he was placed on the Cross. He was denounced, scourged, prepared for death by decree. Today, we call this "excommunication".

About the Speaker:

Sir Laurence Gardner, Kt St Gm, KCD, is an internationally known sovereign and chivalric genealogist. He holds the position of Grand Prior of the Celtic Church's Sacred Kindred of Saint Columba, and is distinguished as the Chevalier Labhrán de Saint Germain. Sir Laurence is also Presidential Attaché to the European Council of Princes, a constitutional advisory body established in 1946. He is formally attached to the Noble Household Guard of the Royal House of Stewart, founded at St Germain-en-Laye in 1692, and is the Jacobite Historiographer Royal.

Editor's Notes:

- Sir Laurence Gardner will be a guest speaker at the 1998 NEXUS Conference, 25-26 July, in Sydney, Australia.
- Correspondence should be addressed to Sir Laurence Gardner, Kt St Gm, KCD, c/- Element Books, Shaftesbury, Dorset, SP7 8DP, United Kingdom.
- Laurence Gardner's book, *Bloodline of the Holy Grail: The Hidden Lineage of Jesus Revealed*, was published by Element Books in 1996 (ISBN 1-85230-870-2 h/c), and is now available in paperback, distributed by Penguin Books (ISBN 1-86204-152-0). It was reviewed in NEXUS 4/01.
- Copies of Laurence Gardner's video presentation can be obtained from NEXUS Office in the UK; and in the USA, from Ramtha's School of Enlightenment, PO Box 1210, Yelm, WA 98597, ph +1 (360) 458 5201, website, www.ramtha.com. Orders from Australia and NZ should be sent to the USA: AUD\$46.00 inc. p&h, for both tapes (specify PAL/VHS).

MAIGALOMANIA!

THE MULTILATERAL AGREEMENT ON INVESTMENT

If ratified, the Multilateral Agreement on Investment will place yet more power and wealth in the hands of transnational corporations while making them even less accountable for their actions.

Part 1

A Briefing by
Corporate Europe Observatory
(CEO) © February 1998

c/- Prinseneiland 329
1013 LP Amsterdam, The Netherlands
Telephone/Fax: +31 30 2364422
E-mail: ceo@xs4all.nl
Website: www.xs4all.nl/~ceo/

Secrecy, haste and intrigue have characterised the negotiations around the Multilateral Agreement on Investment (MAI), the latest plan of the economic globalisation elite for dismantling barriers to investment all over the world in the quest for a progressively more open, global economy.

All of the regional and global economic liberalisation pacts born in the past decade—the World Trade Organization (WTO), the North American Free Trade Agreement (NAFTA), the European Union (EU), Latin America's Mercosur and so forth—will pale in the face of the mighty MAI.

"Investment is a desirable and desired thing... Nonetheless, governments still sometimes find it threatening, because free direct investment limits administrations' ability to control and shape their countries' economic destiny. This is a small price to pay for allowing private sector decision-makers to generate economic benefits worldwide. But it is a price that some governments in some sectors still find difficult to pay. That is a tragedy."¹ (European Commissioner, Sir Leon Brittan)

"The preponderance of restrictions on foreign investment lie outside the OECD area... Business needs the benefits of an international regime to include the fast-growing countries of Asia, Central and Eastern Europe and Latin America."² (International Chamber of Commerce, on the MAI)

CORPORATE EMPOWERMENT

An analysis of the forces behind any of the recent trade and investment regimes reveals that transnational corporations (TNCs), working both nationally and in international coalitions, are active proponents of the prying-open of markets and the removal of barriers to trade and investment. That is certainly the case in the ongoing OECD negotiations on the MAI [popularly pronounced as "my"].

A total of 477 of the world's 500 largest TNCs are based in OECD (Organization for Economic Cooperation and Development) countries, and most of these are organised in groupings like the International Chamber of Commerce (ICC), the US Council for International Business (USCIB) and the European Round Table of Industrialists (ERT).

All of these corporate lobby groups have been directly or indirectly involved in the shaping of the MAI. The reason for their interest in a global investment treaty, intended as much for Third World countries as for the OECD states negotiating the agreement, can be found in the increasing percentage of corporate investment that flows in a southerly direction.

Furthermore, TNCs are tightly allied with the neoliberal politicians governing most of their home countries, and generally play a considerable role in both national and, increasingly, international policy-making.

The 1994 completion of the Uruguay Round and the creation of the World Trade Organization were a great victory for TNCs which, together with their governments, lobbied for the removal of national barriers to the flow of goods and services.

The next logical corporate challenge has been the creation of a treaty which, by dismantling barriers to investment, would provide investors with a so-called "level playing field" across the globe.

The various provisions of this Multilateral Agreement on Investment would ensure the most ideal investment conditions for transnational corporations—including homogeneous and transparent legal and regulatory frameworks, the standardisation of diverse local and national conditions and, best of all, the right to recourse when corporate profits or reputations are damaged.

THE WINNERS AND LOSERS

The agreement will grant TNCs extensive new powers while at the same time denying governments the right to control foreign direct investment in their countries. The rules and regulations which hinder foreign investment and will be dismantled under the MAI are often those that protect workers and jobs, public welfare, domestic businesses, the environment and culture. By subverting national and local priorities to the needs of foreign investors, the MAI poses a dangerous threat to democratic political processes.

The impacts would be the most devastating on poorer countries which would have no chance to build up a balanced economy or break their reliance upon commodity export and resource extraction in the service of industrialised countries and their corporations. Consequences within OECD countries would be different but also dramatic.

THIRD WORLD UNDER SIEGE

Third World opposition to the MAI and other attempts to impose MAI-style policies has been considerable. Simultaneous to the launching of OECD MAI negotiations, the EU-led attempt at a flying start for a MAI-clone treaty, called MIA (Multilateral Investment Agreement), within the World Trade Organization was obstructed by countries like India and Malaysia. They could not, however, prevent the creation of a WTO working group on investment—in which the EU and others continue to push for the commencement of MIA negotiations.

The OECD countries have adopted a multifaceted strategy to reach their aim of investment deregulation in the South. This strategy includes tempting Third World countries to sign on to the MAI, keeping an investment treaty on the burner in the WTO, and using other international institutions like the United Nations Commission on Trade and Development (UNCTAD) and the International Monetary Fund (IMF) to further their objectives.

The most recent offensive for investment deregulation was announced by EU Commissioner Sir Leon Brittan when, in early February of this year, he informed the world that negotiations on a trans-Atlantic free trade zone involving the EU and the US might be launched in May 1998.³

THE RACE AGAINST TIME

After a smooth first year and a half of negotiations, the MAI entered a far rockier phase in early 1997. Problems arose due to demands by OECD countries for an increasing number of reservations and sectoral carve-outs, and also with the high-speed emergence of anti-MAI campaigns in one OECD country after another.

Although serious preparations for the MAI had already begun in 1991, non-governmental organisations (NGOs) representing environment, development, women and other sectors which were sure to be impacted by the MAI were not consulted until October 1997.

The negotiators are now embroiled in a race against time in order to avoid another postponement of negotiation deadlines—a delay that might mean the kiss of death for the MAI. That would be a happy ending indeed for a treaty that would tie its signatory countries to the unfettered "free" global market economic model for 20 years. There would be every reason to celebrate the failure

of a treaty that would increase competitive pressure on wages and policies, facilitate relocations and ban many of the policies desperately needed to strengthen local economies and reduce general dependency on transnational corporations.

OECD: MORE THAN JUST A THINK-TANK

The Organization for Economic Cooperation and Development is an intergovernmental organisation with 29 member countries. More than simply a regional body, the OECD defines itself as an "homogeneous entity" within which member countries share similar economic and political ideologies.⁴ Members include all EU states plus Australia, Canada, the Czech Republic, Hungary, Iceland, Japan, Mexico, New Zealand, Norway, Poland, South Korea, Switzerland, Turkey and the United States of America.

OECD decision-making happens within a "system of consensus-building through peer pressure".⁵ Essentially, this means that member countries ensure that other members stay in line with current OECD policy and direction. Much of this policy and direction is the product of various committees which seek to "knit a web of compatible policies and practices across countries that are part of an ever more globalised world".

Although often described as an intergovernmental think-tank, the OECD is more than that. Member countries send experts and policy-makers to join specialised groups and committees on

approximately 200 subject areas. Such committee discussions often result in formal treaties and agreements in areas such as international investment, capital movements and environmental policy.

MAKE-UP OF THE MAI

In sum, the MAI would require countries to open their economies wide to any interested investor—and any TNC complaints about unfavourable treatment by the host country would be judged in unaccountable international courts. The

main elements of the agreement are as follows:

- The MAI would encompass an extremely broad range of investments. Not only direct corporate investment but stocks, bonds, loans, debt shares, intellectual property rights, leases, mortgages and concessions on land and natural resources would be covered. The health, education, communications, cultural, banking and construction sectors would all be fair game for foreign investors. In fact, the only exempted sectors would be defence and police.

- The MAI is based on the principles of "national treatment" and "most favoured nation" (MFN). In plain language, this would require governments to treat foreign investors as well as or better than domestic investors and thus would automatically favour transnational investment over that of smaller domestic companies. Restrictions placed by countries on foreign investment in sensitive sectors—for example, publishing in Malaysia, Indonesia and Venezuela; forestry, fishing, mining and agriculture in a number of countries; toxic waste in Colombia and highly polluting industry in Taiwan—would be prohibited.

- The MAI would do away with so-called performance requirements—measures designed to protect workers and communities. For example, government requirements for a minimum number of local people being employed in a foreign firm, the use of a certain percentage of domestic products, technology transfer and so forth

By subverting national and local priorities to the needs of foreign investors, the MAI poses a dangerous threat to democratic political processes.

would become illegal under the agreement.

- By banning restrictions on the excessive flow of capital in and out of countries, the MAI would increase speculative short-term investments of the type that caused the 1994 Mexican peso crisis and recent stock market crashes in South-East Asia.

- Unlike other multilateral treaties, the MAI would include a dispute settlement mechanism to allow investors to sue national and local governments for expropriation. This mechanism, which grants powerful TNCs the right to challenge local and national legislation emerging from democratic political processes, is an extremely dangerous political precedent. A ruling of expropriation, which the MAI defines not only as loss of income but also of reputation, requires states to compensate the investor financially and/or to reform laws. The arbitration panel would consist of a few trade experts working behind closed doors, beyond public scrutiny. The ramifications of this provision upon national environmental, health and safety regulations are enormous, as exhibited by an ongoing case under the NAFTA in which the US Ethyl Corporation is suing the Canadian Government for US\$250 million, claiming lost profits and reputation due to the banning of a toxic gasoline additive.

- The MAI would in effect lock-in signatory countries for a 20-year period. A country could withdraw from the MAI only after five years, and companies investing in that country would be covered under treaty provisions for an additional 15 years.

- The MAI would also include the dangerous provisions of "standstill" and "roll-back". Standstill prohibits signatory countries from introducing new laws or policies which contradict the MAI. This provision would have a crippling effect on national environmental and social policy. Roll-back is the procedure by which countries will be forced to open up protected areas and remove laws considered in violation of the MAI. OECD countries have identified

1,000 pages of exemptions which would eventually have to be rolled back—ranging from Austria's exemption of its chimney-sweeping industry to social services in the United States.

- The provisions of the MAI would contradict several international agreements signed by governments, including the Climate Convention and its Kyoto Protocol and the Convention on Biological Diversity.

- The MAI would be a freestanding international treaty, open to accession by non-OECD countries, which means that countries can sign on a take-it-or-leave-it basis, only allowing time-limited reservations. At least 10 non-OECD countries have expressed interest in joining the MAI from the beginning, including Argentina, Brazil, Chile and most likely Hong Kong, Colombia and the three Baltic States of Estonia, Latvia and Lithuania. Egypt is also expected to join.⁶

EXPLOSIVE GROWTH IN TNC FOREIGN INVESTMENT

Global foreign investment was at an all-time peak in both 1994 and 1995, and the 10 per cent worldwide growth in foreign investment in 1996 was also remarkable. Overall, foreign investment growth rates exceed global GNP (gross national product) growth rates (6.6 per cent per year) as well as increases in international trade levels (4.5 per cent per year).

But even the breathtaking US\$349 billion total for foreign

direct investment in 1996 does not capture the breadth and depth of economic globalisation. In the same year, TNCs invested a staggering US\$1,400 billion in countries in which they were already represented. This development—the increased presence of TNCs in local economies as a strategy to ensure market control—has been labelled "glocalisation".⁷

There are in total some 44,000 TNCs in the world, with 280,000 subsidiaries and an annual turnover of US\$7,000 billion. Two-thirds of world trade results from TNC production networks. The share of world GDP (gross domestic product) controlled by TNCs has grown from 17 per cent in the mid-1960s to 24 per cent in 1984 and almost 33 per cent in 1995.⁸

In a parallel and related process, the largest TNCs are steadily increasing their global market shares. According to UNCTAD's "World Investment Report 1997", the 10 largest TNCs now have an annual turnover of more than US\$1,000 billion. Fifty-one of the world's largest economies are in fact TNCs. Continuous mergers and take-overs have created a situation in which almost every sector of the global economy is controlled by a handful of TNCs; most recently, the service and pharmaceutical sectors. In January 1998, for example, the largest business merger in history took place in a US\$70 billion deal in which Glaxo Wellcome and SmithKline Beecham became the largest pharmaceutical company on Earth.

Unlike other multilateral treaties, the MAI would include a dispute settlement mechanism to allow investors to sue national and local governments for expropriation.

This is an extremely dangerous political precedent.

The European Union, the United States and Japan are responsible for 85 per cent of all outgoing foreign direct investment (FDI) (1996 figure). Apart from the Korean Daewoo Corporation, all of the 100 largest TNCs are based in this wealthy triad. This triad has also received the bulk of FDI—nearly three-quarters in 1996. But the new trend is clear: TNCs based in the triad plan to step up their investments abroad, particularly in the Third World. More than half of all TNCs anticipate that the share of their turnover earned abroad will

exceed 60 per cent before the year 2000. In 1997, only 28 per cent of the TNCs were that globally oriented.

TNCs have already indicated their favourite targets for investment. In 1996, China received one-third of all FDI in the developing world and the remaining Asian countries received approximately the same. In Latin America, Brazil led with US\$9.5 billion FDI in 1996, followed by Mexico and Argentina. Africa (minus South Africa) received only US\$5.3 billion that year, of which the oil-producing countries raked in 70 per cent.

THE REAL IMPACT OF GLOBALISATION

The OECD claims that economic globalisation in general, and increased foreign investment in particular, will improve living standards all over the world. However, the experiences of countries which have removed all barriers to foreign investment by joining free trade agreements are quite different. For example, since Mexico signed the NAFTA, real wages in that country have dropped 45 per cent, two million people have become unemployed, and the percentage of the population considered "extremely poor" has risen from 31 per cent in 1993 to 50 per cent today.⁹ It has been demonstrated that those who suffer most from the conditions created with these free trade agreements and the consequent emergence of free trade zones are women and children.

UNCTAD's "Trade and Development Report 1997" concludes

that globalisation in its current shape is responsible for a dramatic increase in global inequality. In 1965, the average personal income in G7 (Group of Seven) industrialised countries was 20 times that in the seven poorest countries in the world; in 1995, the gap was 39 times as large. Polarisation and income inequalities are also growing: the share of income going to the top 20 per cent of the population has increased almost everywhere since the early 1980s. UNCTAD blames the liberalisation of market forces for these developments and considers the current situation inevitable until regulation of the economy is put back on the agenda.

TNCs AND THE ART OF JOB-KILLING

Although TNCs present themselves as creators of wealth and employment, the figures reveal something different. In fact, one of the main characteristics of a competitive and successful TNC is the "shedding" of jobs. Between 1993 and 1995, global turnover of the top-100 TNCs increased by more than 25 per cent, but during this same period the same companies cut 4 per cent of their global workforce of 5.8 million—over 225,000 people.¹⁰

TNC tendencies towards mergers, relocations, automatization and centralisation of production and distribution are recipes for job losses. A part of the obsolete workforce might be employed by subcontractors, a "trouble-free" source of labour which TNCs increasingly make use of. Subcontractors are often skilfully played off against each other, resulting in lower prices as well as reduced wages and worsened working conditions.

Another unfortunate fact about FDI is that it very often leads to the buying up and restructuring of local companies so that they can produce more with fewer employees. Around two-thirds of all FDI in the period 1986 to 1992 consisted of mergers and take-overs.¹¹

The sad truth about TNCs is that the increased growth, investment, monopolisation and concentration upon which they rely, as well as the resulting job losses and environmental degradation, are a structural characteristic of the current neoliberal economic model. However, the voices calling for a halt to this endless pursuit of deregulation are growing louder and are more often coming from unexpected sources. UNCTAD's "World Investment Report 1997" ends with a warning to world leaders that the activities and the market powers of TNCs can in fact undermine the health of the global economy.

GROUNDWORK ON THE MAI NEGOTIATIONS

Although preparations for the MAI have been underway for close to a decade, official negotiations started only in 1995 and the first draft treaty was not ready until January 1997. Whereas negotiations had until this time been a relatively harmonious process involving negotiators from the most neoliberal branches of national governments and corporate lobby groups, the past year has been full of unexpected pitfalls. The combined impacts of conflicts between OECD countries and increasing environmental and trade union opposition have turned the negotiations into a high-speed race towards the finish line.

Talks about something resembling a MAI within the OECD were launched as long ago as 1988, when its investment committee began working to convert existing non-binding OECD agreements—particularly the rules concerning national treatment for

foreign investors—into binding ones. Negotiations lasted for two years but then came to a halt.

The formal reason for the discontinuation was the United States' refusal to give Canada an exemption on national treatment for culture. The underlying motive, however, was the ambition of some negotiating parties, particularly the US, to start negotiations on a more comprehensive agreement on liberalising investment flows.¹²

The next year, in 1991, the OECD Ministerial Conference ordered a study into the feasibility of a multilateral framework for investment. The work was initially carried out by two OECD working groups: the Committee on International Investment and Multinational Enterprises (CIME) and the Committee on Capital Movements and Invisible Transactions (CMIT).¹³

This work was accelerated in 1994, when five working groups "composed of independent governmental experts were set up to prepare the major elements in the MAI".¹⁴ During this preparatory phase, business interests were systematically consulted. Collaboration existed not only with the OECD's Business and Industry Advisory Council (BIAC), which unites numerous business associations and has formal consultative status at the OECD, but also with individual corporate lobby groups such as the ICC.

At their May 1995 conference, the OECD country ministers decided to initiate negotiations on a MAI, with the goal of completing an agreement by May 1997.

The OECD countries made no secret of their intentions to negotiate a treaty with the "highest standards" of protections and rights for foreign investors, only afterwards inviting non-OECD countries, mainly in the Third World, to join. The process of soliciting non-EU members started soon afterwards, in the first of a series of ongoing negotiations with interested countries.¹⁵

NGO observers following the negotiations between the EU and the ACP (African, Caribbean and Pacific)

countries about a revised Lome Convention¹⁶ report that the EU is pressuring these former European colonies to accept the MAI as part of a new Convention.¹⁷

From the outset, the MAI was also intended to prepare the ground for a global investment treaty within the World Trade Organization.¹⁸

The main building blocks of the MAI as we know it—including its all-encompassing definition of investment and the principles of national treatment, roll-back, standstill and so forth—were in place from the start of the negotiations, thanks to the four-year feasibility study.

Official negotiations kicked off in September 1995 in a negotiating group chaired by Dutchman F. A. Engering, with representatives of all OECD states as well as the European Commission. The WTO was invited as an observer.

Since that time, this negotiating group has met every four to six weeks, and working or drafting groups convene more frequently. Between meetings, delegates circulate texts and positions through electronic mail.¹⁹

COSY CONSULTATIONS WITH BIG BUSINESS

Business has had direct input in the MAI framework throughout the entire negotiation process. Apart from the formal consultations carried out by the negotiating group with both the BIAC and

Although TNCs present themselves as creators of wealth and employment, the figures reveal something different. In fact, one of the main characteristics of a competitive and successful TNC is the "shedding" of jobs.

Trade Union Advisory Committee (TUAC), an "ad hoc group of BIAC experts...meets with and advises OECD negotiators prior to each negotiation session".²⁰ The negotiators have made extensive use of the "expertise" of the ICC, for instance, in shaping the dispute settlement mechanism. In fact, the ICC's own court of arbitration is one of the three possible bodies to which corporations can turn for dispute settlement purposes.²¹

No less important than these direct injections into the OECD process is the lobbying done by industry on the national level. For example, USCIB has "regular meetings with US negotiators immediately before and after each MAI negotiating session".²² Similar close cooperation between industrialists and national negotiators has taken place in many other OECD countries, including Canada and the Netherlands. The pressure by the Dutch negotiators on the US to withdraw its reservation on research and development (R&D) subsidies was a direct result of lobbying from Netherlands-based TNC, Philips. Philips wanted to ensure its access to R&D subsidies in the US.²³

Corporate lobby groups like the ICC and the ERT have used their political access at the highest political levels—including summits of global importance, such as the G7—to stress the need for a speedy completion of the MAI and for keeping the agenda clear of labour and environmental demands.

The basis for the cosy consultations between governments and corporate lobby groups throughout the MAI drafting process is that the business agenda is wholeheartedly embraced by several of the most influential negotiating delegations. The ICC's April 1996 "Multilateral Rules for Investment" report leaves no doubt about the almost complete consensus between the MAI negotiators and industry.²⁴ The rules proposed in the report are basically identical to the first MAI draft that was completed nine months later.

Generally, economic or trade ministry officials represent their countries in the MAI negotiations in the OECD. In the Netherlands, the traditionally close connections between industry and economic and trade ministries have been exploited to their full potential. The Dutch negotiators sided with industry in their mutual aim to get "as many obstacles as possible to foreign investment removed".²⁵ Secretary of State for Economic Affairs Van Dokvan Weelen reported to the Dutch Parliament in November 1995 that national treatment should also apply to "issues like public procurement and the granting of all kinds of subsidies and guarantees".²⁶ In many countries, the MAI went largely unnoticed by other ministries, e.g., those of environment, social affairs and culture, until a very late stage.

"RESERVATIONS" ON BOTH SIDES

The first draft of the MAI saw the light of day in early 1997. Until this time, the agreement had been sailing along quite smoothly, with the general public and even most elected public officials oblivious to its very existence.

But both the complicated reservation process and the discovery of the MAI process by the NGO community have served to slow down and perhaps even fundamentally disrupt the charted course of the planned agreement.

Governments submitted their "reservations" to the MAI in February 1997, and, in addition to the sheer volume of national

exceptions, governments chose to exempt some core, open-ended areas of the agreement. In some countries, the exemption process probably involved government representatives who had previously been uninformed about the MAI and were now reacting with cold feet to the far-reaching provisions of the agreement.

Some of the major core exemptions proposed by member states are:

- The US demanded an exemption for sub-federal law, which would provide states and localities with immunity from the MAI.
- The EU asked for positive discrimination for investment within regional economic integration organisations (REIOs) like itself. The aim of this clause is to ensure that the MAI would not prevent countries from changing their laws to match EU legislation. This could be of crucial importance for Central and Eastern European countries waiting for EU membership as well as for the future possibilities of harmonising EU legislation.
- France and Canada requested that culture be carved out of the agreement entirely.
- The EU made noise about the need to ban secondary boycotts, such as the US Helms-Burton Act which penalises companies doing business with Cuba.
- Many governments discouraged the proposed ban on the use of tax measures which could, for example, favour domestic or smaller enterprises.

The first draft of the MAI saw the light of day in early 1997. Until this time, the agreement had been sailing along quite smoothly, with the general public and even most elected public officials oblivious to its very existence.

To add insult to injury, country-specific exemptions to the MAI now total a hefty 1,000 pages, with some governments exempting page after page of the key sectors of their economies.²⁷

The serious impacts upon the treaty of these far-reaching reservations, such as culture, and the daunting volume of the specific exemptions have served to unsettle the previously trouble-free MAI negotiations.

A decision to postpone the deadline for the negotiations until May 1998 was taken at the May 1997 OECD

Ministerial Conference, with ministers arguing that a "high standard" MAI required more time.

EXPLOSIVE PUBLIC REACTION

The second and simultaneous spanner in the MAI's works was the explosive reaction of the international NGO community after a draft text of the MAI was leaked at the beginning of 1997. Canadian and US NGOs were quick to put the draft text on their websites, and campaigning spread like wildfire to other parts of the world.

NGO strategies have included public education, lobbying of government officials and parliamentarians (many of whom first heard about the MAI from the NGO community), and, in October 1997, the organisation of a global NGO strategy meeting on the MAI and a simultaneous informal consultation with the OECD. The consultation/strategy session brought together representatives of development, environmental and consumer groups from over 70 countries and resulted in a call for a major overhaul of the agreement.²⁸

NGOs and trade unions have successfully injected two new demands into MAI negotiations: the integration of labour and environmental standards in the agreement. For industry, these demands, taken in conjunction with the cumbersome reservation process, are intolerable.

Recently, the OECD's Business and Industry Advisory Council began a new offensive after realising that its dream MAI was on the verge of being derailed. At an official consultation between BIAC and the OECD's MAI negotiating group in January this year, industrialists expressed concerns about the direction the discussions were taking. Herman van Karnebeek, Chairman of BIAC's Committee on Multinational Enterprises (as well as of chemical giant AKZO Nobel and the Dutch branch of the ICC), complained: "We now hear of disturbing signs that many of the elements we were hoping for may not be possible. What then, we are beginning to ask ourselves, is in the MAI for us?"²⁹

Some BIAC members, particularly annoyed at the carve-out of taxation and the introduction of labour and environment standards, went so far as to threaten that business might withdraw its support for a sub-standard MAI, which would make ratification difficult in many countries. OECD negotiators calmed members' fears by asserting that liberalisation remained at the top of their agenda, but that compromises were necessary in order to complete the MAI by April 1998. "Remember, this is only the first step—like the GATT in 1947," BIAC was consoled by an OECD official. "We are entering a process of historic dimensions."³⁰

BIAC: BUSINESS BEHIND THE SCENES

The Business and Industry Advisory Committee (BIAC) is the official voice of business in the OECD's MAI negotiations. Based in Paris and established in 1962 like the OECD itself, BIAC is regularly consulted by the OECD both formally and informally.

BIAC consists of the employers' organisations of OECD member countries as well as industrial lobby groups like UNICE (the Union of Industrial and Employers' Confederations of Europe), Canada's Business Council on National Issues (BNCI), USCIB, the ICC, the World Business Council for Sustainable Development (WBCSD) and others. Some individual corporations including Shell, General Electric, BASF and Kobe Steel are also represented. BIAC is organised into 14 committees which work on issues ranging from trade, education and chemicals to international investment.

BIAC has been an enthusiastic supporter of the MAI from the beginning of the negotiation process and was actively involved in pre-negotiation work between 1991 and 1995. There have been a number of formal consultations between BIAC and the negotiation group, but perhaps more significant has been the work done behind the scenes. For example, an ad hoc group of BIAC representatives meets informally with the OECD negotiators prior to each negotiating session.³¹

TRADE UNION ADVISORY COMMITTEE (TUAC)

Like its corporate counterpart, the Trade Union Advisory Committee (TUAC) has consultative status within the OECD and has a small secretariat in Paris. It represents over 55 trade union organisations in the industrialised world and counts a total membership of 70 million workers.

TUAC sees its role as "ensuring that global markets are balanced by an effective social dimension".³² Accordingly, TUAC has stressed the need for binding social and environmental standards in the MAI since consultations during the feasibility studies

in the early 1990s.³³ Although OECD negotiators have never taken these recommendations seriously, Roy Jones of the TUAC Secretariat points out that the recent difficulties in the negotiations show that TUAC is right: "labour and environment can blow the treaty apart".³⁴

MAI AND THE EUROPEAN UNION

In addition to the 29 OECD countries, the European Commission has been represented as the 30th negotiator throughout the MAI negotiations. Although the legal status of the Commission's role is unclear, the MAI is being treated as a matter of shared responsibility between the European Commission and the member states.³⁵ In contrast, the Commission negotiates on behalf of the 15 member states in the World Trade Organization, a result of paragraph 113 in the Maastricht Treaty which gives the EU competence over a major part of the external trade policies of its member states. Although shared responsibility allows the Commission to play an influential role in the negotiations, it also means that the MAI will have to be ratified by the Council of Ministers.

Overall, the Commission has played an increasingly important role in coordinating EU member-state positions as the MAI negotiations have proceeded. This might be attributed to the ambitious leadership in the negotiations by Sir Leon Brittan, of Directorate

General I (External Economic Relations)—a man well known for his aggressive, competitive approach to trade and investment matters. The EU is simultaneously pushing for a mechanism for investment liberalisation both within the OECD negotiations and the WTO. As Sir Leon Brittan said: "We need to tear down existing obstacles to investment and stop new hurdles being thrown up in its way. Nothing short of a comprehensive set of binding international rules will create the level playing field which is so vital for the European economy."³⁶

And with its far less subtle approach, the IMF continues to use every opportunity to impose MAI-like rules on countries in financial crisis.

MAI AND THE EUROPEAN PARLIAMENT

To date, the European Parliament has been granted no formal role in the MAI negotiations, nor does it have the legal right to ratify or reject the agreement. However, on its own initiative, the Parliament has brought out a resolution on the MAI for discussion in February and most likely a vote in March 1998.

The first draft of the resolution, written by German Green MEP Kreissl-Doerfler, is highly critical of both the MAI and the negotiating process, and stresses "the fact that the negotiations have hitherto been conducted in utmost secrecy, with even the parliaments being excluded".³⁷

The draft resolution states that the MAI "reflects an imbalance between the rights and obligations of investors, guaranteeing the latter full rights and protection, while the signatory states are taking on burdensome obligations which might leave their populations unprotected". The resolution demands that binding social and environmental standards be included in the MAI, as well as a guarantee that the MAI will not lead to competition on rules in order to attract foreign investment.³⁸

In addition, the so-called regional economic integration organisation (REIO) clause is a high priority for the European

Continued on page 86

The Secrets of Dr Rife's Resonant Energy Device

Some of the microbe-killing radio frequencies of Dr Rife's original ray beam device have now been duplicated with encouraging results.

Part 2

by James E. Bare, DC ©1997

8005 Marble Avenue, NE
Albuquerque, NM 87110, USA
Telephone: +1 (505) 268 4272
E-mail: rifetech@rt66.com

EARLY DEVELOPMENTS IN RADIO-FREQUENCY DEVICES

In part one of this article, an overview of the electronic therapeutic device invented by Dr Royal Rife was given, together with an in-depth look at the modern-day counterpart of the original Rife device, the Rife/Bare device. The original Rife device has been a mystery for over 60 years, but now that mystery has essentially been solved.

To begin this account, an examination of a small piece of history is necessary to determine what the actual device was. Pre-dating Rife's electronic instrument was another device, developed in the year 1918 by Albert Abrams, MD.

Dr Abrams developed a treatment device known as the "Tick-Tock" Oscillator (for its metronome-like action). This was a shock-excited, low-power, short-wave-emitting instrument that operated in the 43-megacycle band. Over 2,000 of these instruments were distributed throughout the world. In 1931 he developed an improved instrument, the Oscilloclast, also operating in the 43-MHz band. This was merely a modernised version of the Tick-Tock Oscillator.

The Oscilloclast produced three types of waves: one type was a short wave (as in short-wave radio); the second was an impulse-excited, damped wave of about 90 Hz per minute or 1.5 Hz per second (think of this as a ringing bell); and the third was a kind of alternating magnetic energy. The radio energy emitted by the Oscilloclast was of very low power, being in the milliamperage range and incapable of producing a heating effect. The short-wave radio energy in the Abrams device was generated with a 50 per cent duty cycle; that is, the power is on for as long as it is off. This energy was pulsed at a rate of 90 Hz per minute. One could easily think of this as a continuous wave (CW) transmitter, outputting sequentially spaced dashes generated by closing a telegraph key every 1.5 seconds. In other words, the pulse was 0.75 seconds long and was then off for 0.75 seconds. The 43-MHz carrier wave, which was pulsed 1.5 times per second, was modulated by the ripples in the half-wave 60-Hz AC power from the wall socket; meaning that a 60-cycle tone—again, a 50 per cent duty cycle—was carried on the radio wave. One could hear this 60-cycle tone in a radio receiver tuned to the 43-MHz frequency of the transmitter.

The Oscilloclast also provided a pulsed, alternating magnetic energy through a pair of depolarising electrode plates. The magnetic energy could be measured at about 80 gauss close to the device. The electrodes were placed in close proximity to, if not actually touching, the patient. The depolarising electrodes had a choke coil to prevent the radio waves from entering the circuit. In order to treat a disease, the Oscilloclast operator would vary the output frequency of the short-wave transmitter in 10 steps from about 43.000 MHz to 43.357 MHz. The frequency chosen was of course based on the patient's complaints.

To sum all this up, the Oscilloclast was a low-power radio transmitter with a variable radio frequency output. The device produced a gated train of radio frequency pulses that were modulated with a 60-Hz audio frequency wave, and the patient was connected to alternating magnetic energy depolariser electrodes of about 80 gauss with a 1.5-second cycle.

To some people reading this explanation of the Oscilloclast, it should be apparent that what Dr Abrams invented was a very early version of a nuclear magnetic resonance (NMR) instrument. Modern magnetic resonance imaging (MRI) scanners use a fixed magnetic field with a variable frequency pulsed radio energy to make their pictures of the interior of the body.

Now that we know all that, what does it have to do with the original Rife device? I

believe that the original Rife device is a direct derivative of the Abrams device. There are some slight differences—namely, the power levels are many times greater in the Rife unit—yet the emanated radio wave from the plasma tube is very slight, like in the Abrams device. The Rife unit had a variable pulse rate of from about 1 to 4 Hz per second; it used a much wider variation in the radio frequency band than did the Abrams unit; and Rife used a plasma tube as an antenna. Mortal oscillatory rates (MORs) were given only in radio frequencies, as originally there was no (modulated) audio frequency MOR.

It is my thought that the reason Rife never patented his device was due to its extremely close kinship with the Abrams Oscilloclast and another device of the era, known as a Violet Ray device.

The Violet Ray device was simply a handheld Tesla coil attached to an argon-filled glass tube. The Tesla coil produced damped, shock-excited oscillations in igniting the tube. Due to its construction the Violet Ray, like the Oscilloclast, would modulate 60 Hz AC wall power. Large versions of the Violet Ray device were apparently pioneered by Nikola Tesla as a therapeutic device in the late 19th century.

So how did the original Rife device operate? Nowadays we all think in terms of audio frequency MORs. For example, the known audio MOR of cancer is 2,128 Hz. But Rife gave an MOR of 28,825,455 Hz. In other words, there was no direct modulation of an audio frequency with the original Rife device!

The original Rife device merely used a variable radio frequency with a variable pulse rate. This pulsed radio wave was output to a gas-filled tube. The pulse was generated by controlling the output of the transmitter to the plasma tube. In an available video of Dr Rife using his unit, the pulse of the tube can clearly be seen. This pulse was a complete on/off cycle, and the tube did not stay lit between pulses. Such a shock will produce immense radio-energy harmonics.

How and why the variable audio MORs used today came into

being is still unknown. But certainly, the fact that a 60-Hz modulated wave was important to the Oscilloclast's operation had to play some part in the development of the audio MORs in the Rife device.

ILL-FATED RESEARCH WITH A RIFE-TYPE DEVICE

A recent series of letters from an individual known by his Internet name as "Cisco" has shed even more light on the original Rife instrument. In 1934 two doctors in Denver, Colorado, respectively named Clayton and Cooperson, were working with what is assumed to be a Rife instrument.

Several years ago Cisco was given access to Dr Clayton's seven notebooks. Cisco took notes from these notebooks as they seemed to be important, but no mention of Rife was ever made in the entries. Cisco later found out that Dr Clayton's relative, who owned the notebooks, had thrown them in the trash!

Cisco's story of Dr Clayton is most revealing. Besides the plasma tube, the radio transmitter and the variable pulse rate, Clayton connected his patients to a couple of alternating depolarisers.

The depolariser was designed to deliver an alternating DC electrical current that would change from positive

to negative as the radio-energy-driven output bulb pulsed. The output of the depolariser would appear much as a square wave would look on an oscilloscope; that is, the pulse would be positive for half of the time of a flash cycle and then abruptly become negative for the remaining half of the cycle when the tube wasn't flashing.

The patient would sit in a wooden chair with his feet on a metal plate and would hold two electrodes in his hands. At a later date, a pair of electrodes was added to the back of the chair to get more current into the torso area. The use of a foot plate and handheld electrodes is an application technique typical of modern electric-current Rife-type frequency devices.

Dr Clayton and his partner Dr Cooperson later became caught up in the politics of the situation. They suffered from the economic reality of the Depression, and research slowed. The final straw was that the US Government threatened both doctors with prosecution on sedition charges.

In order to raise funds, the two doctors had become involved with a rather mysterious but wealthy German, and a Swiss financier. They had also had frequent contact with a German microscopist. Problem was, of course, that the good doctors were dealing with people in what had become Nazi Germany. In retrospect, their innocence of the situation was certainly something of their undoing, but this was the Depression and money was scarce.

As an example of how economically stressed things were in this era, one major American newspaper magnate was receiving payments from Nazi Germany to print favourable articles in his newspapers about the Nazi regime.

The original Rife device merely used a variable radio frequency with a variable pulse rate. This pulsed radio wave was output to a gas-filled tube.

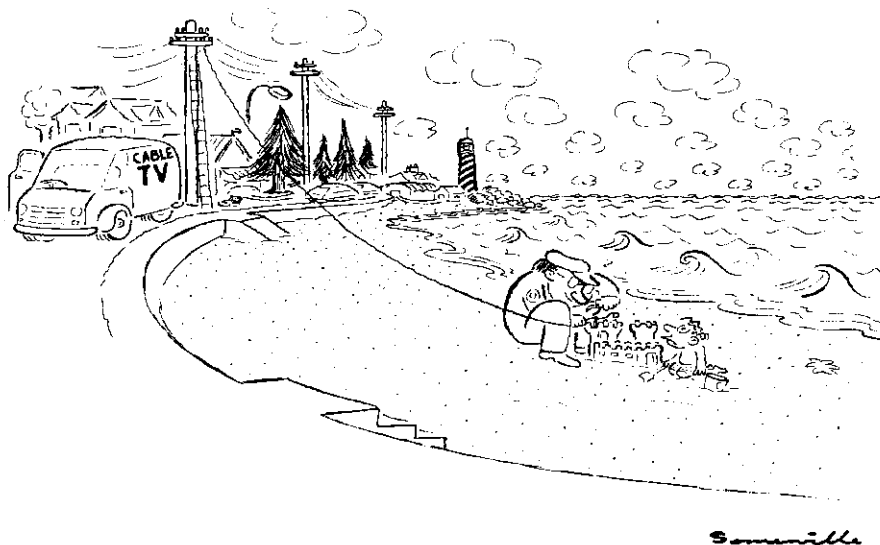

The US Government finally confiscated Clayton's and Cooperson's equipment and lab notes as it considered them a security threat. Cooperson committed what was deemed a suicide in 1940, and Clayton was poisoned shortly thereafter. Clayton's death was initially listed as a suicide, but later lab tests showed the presence of a rather nasty poison cocktail in his system. Did the US Government do this foul deed, or did the Nazi regime? Only history knows the answer.

DETERMINING THE MORTAL OSCILLATORY RATE

One of the most significant facts to come from Dr Clayton's journals is how the microscope that Dr Rife invented was used to determine MORs. By using a pair of counter-rotating prisms under the microscope stage, a projected beam of monochromatic light could be emitted into the specimen on the stage of the microscope. At a certain colour, the cell would re-radiate a different colour. This was done with live cells and could be considered staining with light, or a variant of what is known as "Rheinberg illumination".

In the Rife microscope the cell would be coloured, and the remaining field would be white as in a standard bright-field microscope. When the MOR was reached, the cell in question would lose its colour and become clear as it absorbed the resonant energy and changed or died.

That is the technique Dr Rife used to find his MORs, and certainly it has applicability today with modern microscopes.

For those who would think of replicating Dr Rife's original instrument, some radio frequency (RF) MORs are known. These frequencies are directly from Rife's notebook. In his notebook are two frequencies, and it is believed that the frequencies were combined in either the final output stage of the transmitter or were injected simultaneously into the globe plasma tube. One of the frequencies is given directly, and one of the frequencies is given indirectly as a wavelength of the super-regenerative audion tube.

Wavelength is converted to frequency by this formula: Frequency (Hz) = the speed of light in metres per second divided by the wavelength in metres; i.e., frequency = 3×10^8 metres per second / wavelength.

There is a complication here, known as heterodyning, and if the frequencies are to be combined within the plasma tube then one must account for this possibility. With heterodyning there could be another wave emanating from the tube that is the difference between the two frequencies and not their sum.

Carcinoma: 11,780,000 Hz; wavelength of the super-regenerative audion tube is 17 and 6/10 metres, or 17,045,455 Hz. The MOR is therefore 28,823,455 Hz or 5,265,455 Hz.

Streptococcus: 1,241,000 Hz; wavelength of the super-regenerative audion tube is 142 metres or 2,112,676 Hz. The MOR

is therefore 3,353,676 Hz or 871,676 Hz.

Staphylococcus: 998,740 Hz; wavelength of the super-regenerative audion tube is 540 metres or 555,556 Hz. The MOR is therefore 1,554,296 Hz or 443,184 Hz.

Tuberculosis: 583,000 Hz; wavelength of audion tube is 554 metres or 541,516 Hz. The MOR is therefore 1,124,516 Hz or 41,484 Hz.

RIFE DEVICE REFINEMENTS

My present thought is that an optimised device could be constructed using a variable frequency radio transmitter with modulated square-wave audio MORs and a variable audio pulse rate.

My device, the Rife/Bare unit (I didn't name it this; people using one of my devices did) is much like this. A gated audio pulse can be generated with modern audio frequency oscillators, while the pulse rate of the carrier wave varies automatically with the applied audio frequency. The RF pulse can be adjusted electronically for its "duty cycle". My instrument also has a fixed radio frequency of 27.12 MHz. A variable radio frequency will most certainly create all sorts of radio interference and cause oneself some legal problems if the device is not properly shielded for RF emissions.

I must warn potential constructors of the original Rife unit that the device should not conform tightly to known radio operational aspects. The original Rife device from Clayton's journals was something like my device and was quite temperamental.

For my device to work properly and optimally, the device must be self-resonant. Precise cable lengths, position and types of components, grounding circuits and feedback loops of the radio energy are necessary for my device to work. These variables have been determined for my device, and all one needs to do is to follow the instructions. Finding these variables for a re-creation of the original may be quite problematic.

Clayton's death was initially listed as a suicide, but later lab tests showed the presence of a rather nasty poison cocktail in his system.

Did the US Government do this foul deed, or did the Nazi regime?



Original Rife beam ray unit of about 25 watts power; uses 809 output tube.

FUTURE OUTLOOK

I realise that this information is highly controversial. Over the years, so much has been written about the Rife device that is misleading or erroneous that it has become hard to determine fact from fiction. Re-creating the original Rife device will be quite an undertaking.

The true tragedy of Dr Rife is that his research was lost. We are over 60 years behind where we should be with the development of Rife's instruments.

The worldwide toll in human lives and suffering in the past 60 years is too great to be imagined, too horrifying to be comprehended. The future of my device is secure: far too many copies of my book, telling people how to make the device, are in circulation.¹ Far too many people have a device and also know how to make the device. These same device-savvy people no longer need a book to guide them and are located diffusely in various countries around the world. There is no way to stop what is about to happen.

Since August 1997, the first Rife/Bare devices have been constructed in Russia, China, Indonesia, Saipan and Vietnam. In mid-October 1997, the world's first Rife Technology Symposium was held in Canada, with 148 people attending from a multitude of countries around the world including England, Australia, the Netherlands, Canada and the USA.

It was rather nice to have PhDs, MDs and DCs all working together, but, better yet, it was the *non* health care professionals who made this event happen, and it was from this group that nearly all the device's growth has come. This is the same group whose members ante up a lot of their money every year to fund all sorts of medical research that does them little good. This is also the same group that, as time goes on, will see that some money is redirected to *health care* research (there is a difference!) and the growing worldwide use of the device.

I will not make specific predictions about the future and how the machine is about to change it. The course is set and we are moving towards a new shore, but how we finally get there is a question that destiny must decide.

Endnote

1. Bare, James, DC, *Resonant Frequency Therapy: Building the Rife Beam Ray Device*, James Bare, Albuquerque, NM, USA, 1995-96.

About the Author:

James E. Bare is a Doctor of Chiropractic who has been practising for over 20 years in Albuquerque, New Mexico, USA. An electronics tinkerer since his early teens, he set to work on a prototype Rife instrument after reading Barry Lynes' book on Rife in late 1994. By mid-1995 his prototype unit worked well with pain and muscle relaxation. By late 1995 he added overmodulated pulse to the device, and from then on his Rife/Bare device started producing astounding health effects, though he does not use it to treat patients in his chiropractic practice. Bare works an average of 100 hours per week, with device-related matters occupying two-thirds of his time. He believes he is able to work such long hours because of the vitalising effects of exposure to the device.

RESONANT FREQUENCY THERAPY Building The Rife Beam Ray Device

Construct an operational Plasma Emission Therapy device!

Once considered a lost technology, the Plasma Tube Frequency Device of Dr Royal Rife has surfaced from the depths of forgotten history and returned. My book explains how you can easily construct and operate this modern and updated version of Dr Rife's instrument. The device is made from freely available off-the-shelf components, and operates on 12 volts DC. A list of all components and suppliers may be found in the book. Join over 1,000 other constructors of this instrument who are now operating their own devices.

Book - US\$25.00

Videotape - US\$20.00 (NTSC and PAL-VHS formats only)

100-minute videotape shows effects on protozoal organisms and how to assemble the unit.

Postage: USA and Canada add US\$5.00

Overseas: add US\$10.00

Visa and Mastercard accepted. All money orders should be in US currency. All shipments are sent via airmail. You may fax, mail, or call in your order to our office.

Direct all orders to: **James E. Bare, D.C.**

8005 Marble Ave, NE, Albuquerque, NM 87110, USA

Email: rifetech@rt66.com

Phone: 505-268-4272; Fax: 505-268-4064

The Case for Atlantis in Antarctica

After detailed analysis of ancient maps and Plato's writings, researcher Rand Flem-Ath concludes that Antarctica is the site of the fabled lost continent of Atlantis.

Part 1

by Rand Flem-Ath

Extracted and edited from a transcript of his lecture, "Atlantis and the Earth's Shifting Crust", presented at Return to the Source Symposium, held at the University of Delaware, USA, 28 September 1996

We all know that the greater mass of an iceberg is hidden, unseen beneath the surface of the water. And likewise, underlying the search for Atlantis lie many deep prejudices. Some of these prejudices revolve around time. Our twentieth-century faith in progress propels us towards the future, leaving the past behind at a constantly accelerating rate. But here, at the Return to the Source Symposium, we are invited to face the past. This event is an opportunity to turn to the past for knowledge and perhaps even some wisdom.

I believe that Plato's famous account of Atlantis is a holographic fragment, a sliver of a once common view of the world. In order to reconstruct that world-view we must revise our own assumptions about geography. Words like "Atlantic", "Libya" and "Asia" had a different meaning to the ancient Greeks than they do to us today. When we realise this, Plato's account of Atlantis can be read without distortion and we can follow his clues to their logical conclusion. But in order to understand this Atlantean world-view, we need to reconsider our own presuppositions about geography.

Figure 1 shows a map of the Earth centred on North America, and although you may not have seen this particular projection before, the world is still recognisable; it doesn't challenge any of our current beliefs. North is "up" as it is always traditionally depicted. I should say here that this only a tradition—there is no such thing as "up" when the Earth is seen from outer space. Notice how the "north is up" perspective causes the oceans to appear as distinctive bodies of water. The Pacific and Atlantic seem to be entirely separate oceans. This "north is up" viewpoint also highlights the separateness of the continents.

Now, in figure 2, you see a map of the world showing south in the "up" position. Plato's account of Atlantis places the lost continent in what he calls the "real ocean", and we can see what he meant in this US Navy projection of the world as seen from Antarctica. Notice how all the "oceans" that we know today—the Atlantic, Indian and Pacific—are really one ocean. This is a geographic fact—as is recorded in Plato's account of Atlantis.

Plato expands on this description to say that the Mediterranean Sea is merely a basin of the ocean, separated from it by a narrow channel. From this perspective it is certainly accurate to say that the Mediterranean Sea is really a part of the "World Ocean", separated from it by a narrow entrance at the place we call the Strait of Gibraltar. Seen from Antarctica, the rest of the continents form a ring around the "real ocean". Plato talks about "the whole opposite continent"—a phrase that makes sense once we view the world from Antarctica. This "whole opposite continent" has not been understood before. Most researchers into Atlantis treat it as gibberish or they imagine that it must refer to America.

Plato acquired the record of Atlantis from his ancestor Solon. In Solon's time, the Earth-island was divided politically into Europe, Libya and Asia (see figure 3). "Libya" included all of North Africa. "Asia" was an area which covered what we would call "the Middle East". I will be returning to the size of Libya and Asia in a moment, but I want you to notice that surrounding this Earth-island was a vast ocean that the Greeks called "the Atlantic". This body of water circled the Earth-disc. Most researchers have mistaken "the Atlantic" to be the North Atlantic Ocean, but for the Greeks of Solon's time the Atlantic was a body of water that completely encircled the world. It lay to the west, yes, but it also lay to east, north and south. So in its true historic sense, the Atlantic was a much larger body of water than just the North Atlantic.

At the westerly extreme of the ancient Greek world were the "Pillars of Heracles"—what we know today as the Strait of Gibraltar. It is a narrow entrance which separates the

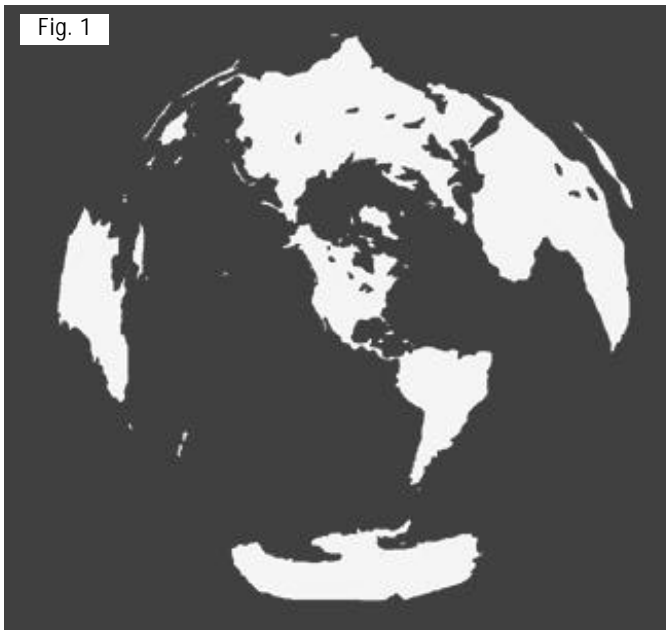

Fig. 1

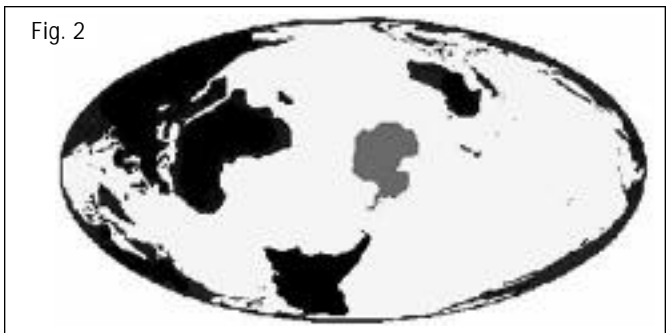

Fig. 2

Mediterranean Sea from the outer ocean. The Pillars of Heracles were the limit of the known world to the Greeks of Solon's time. Land which lay outside this channel was unknown to them.

Plato describes Atlantis as a mountainous, high-altitude island larger than Libya and Asia combined. That would make it slightly larger than the lower forty-eight American states.

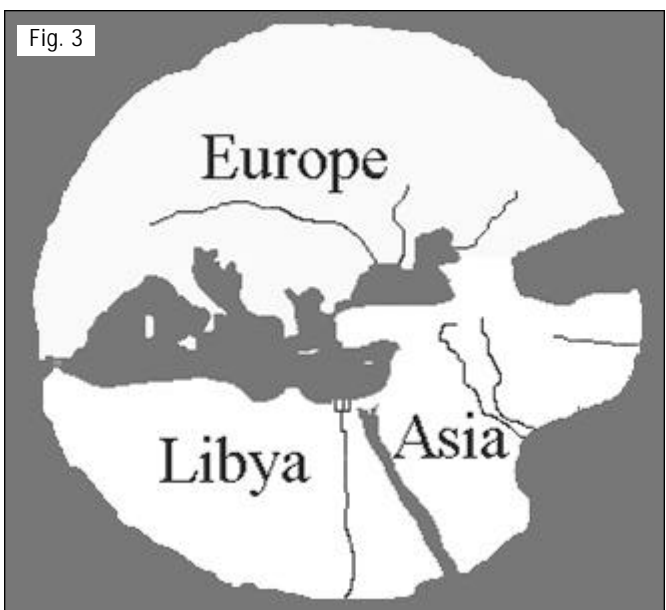

Fig. 3

Antarctica, like Libya and Asia, is slightly larger than the US. I have separated Lesser Antarctica from Greater Antarctica (see figure 4) because I want to treat these areas separately later on.

The mere fact that Plato tells us that the Earth contains a vast island continent the size of Antarctica is amazing in itself. He goes on to give us a most interesting clue. He says that the whole island-continent is high above sea-level. And this is true about...Antarctica! As you can see from figure 5, Antarctica is by far the highest-altitude continent on our planet.

The Egyptian priest spoke to Solon about Atlantis in terms he could understand. He passed on the account as an Atlantean would who was describing his home from the shores of the lost continent before its destruction around 9,600 BC.

In figure 6 we see the world as it would have looked from Atlantis. The ocean level is lower (as it was nearly 12,000 years ago), joining England to Europe and Japan to Asia. Lesser Antarctica is depicted in its former ice-free state. Notice the accompanying islands. Here are Plato's words:

...island outside the channel which your countrymen tell me you call the 'Pillars of Heracles'. This island was larger than



Fig. 4

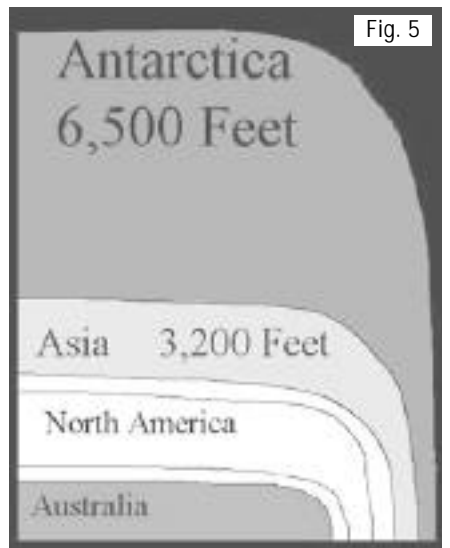
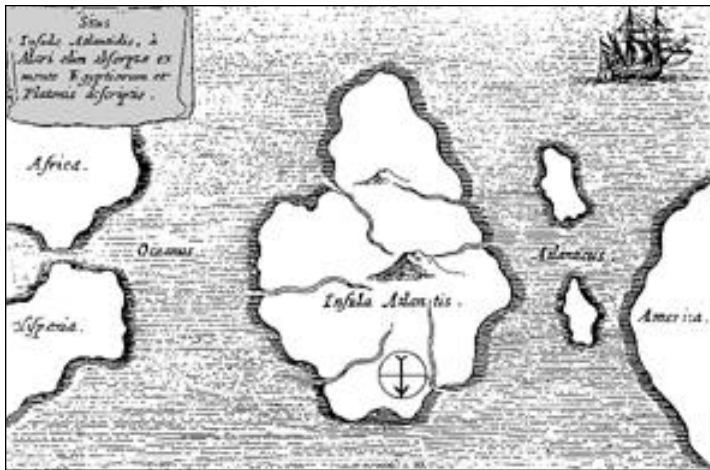

Fig. 5



Fig. 6



the only source that points to Antarctica as the location of Atlantis.

In 1665, the German Jesuit priest Athanasius Kircher published *Mundus Subterraneus*, a massive book which includes a reproduction of an ancient Egyptian map of Atlantis. The map had been stolen from Egypt by the Romans, probably after the fall of Cleopatra.

Now when the map in figure 7 came into Kircher's hands, he didn't possess an accurate globe with which he might compare it. Let's first look at the map as he saw it. The label in Latin translates to "Site of Atlantis, now beneath the sea, according to the beliefs of the Egyptians and the description of Plato".

The Egyptians believed that south, not north, was at the top of the world. This made sense to them because that was the direction from which the Nile flowed. And since the Nile was so important to them, its source had to be at the top of the world. Kircher's map accepts the Egyptian concept that "south is up", as can be seen by his compass which points downwards. To re-establish our familiar "north is up" perspective, we have to turn the map upside down.

Kircher believed that this ancient Egyptian map represented Atlantis as an island in the North Atlantic Ocean between Spain and Africa on the right and America on the left (see figure 8). But what if Kircher got it wrong? What if the limited geographic knowledge that he had at his disposal caused him to locate Atlantis in the wrong place? Let's imagine that we have just excavated this ancient Egyptian map from beneath the paws of the Sphinx. It is our task to discover how it fits into our planet's geography. If we remove Kircher's labels and symbols we can see more clearly what he must have had at hand in 1665.

Here's what Kircher must have been working with (see figure 9). Now, if we search the globe for a place that might fit this configuration, we find a near-perfect match in a place where south would naturally be "up".

Here's Kircher's Egyptian map of Atlantis (see figure 10) compared to a modern geophysical globe showing south in the "up" position. The present shape of ice-free Antarctica as depicted in this modern view is based upon the current ocean level, not that of 9,600 BC. Atlantis did not actually sink beneath the waves: instead, as the old ice-caps melted, the ocean level rose, covering some of the continent's permutations. Further distortions in our modern map, compared to Kircher's, are a

Libya and Asia together, and, from it, seafarers in those times could make their way to the others (islands) and thence to the whole opposite continent which encircles the true outer ocean. (The waters within the channel just mentioned are

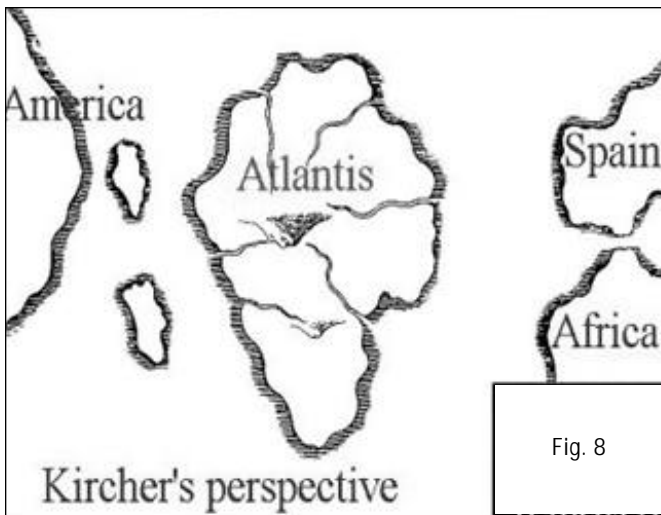

Fig. 8

manifestly a basin with a narrow entrance; what lies beyond it is the real ocean, and it is land enclosing the ocean which should rightly be called a continent.)

Plato's account is not just a figment of his imagination; it is a fragment from a lost world.

Now I've spent a lot of time on Plato because I don't believe his contribution to lost knowledge is fully appreciated, but he is not

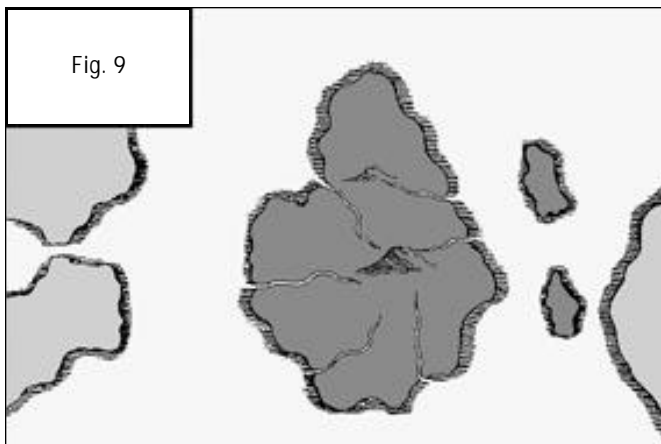

Fig. 9

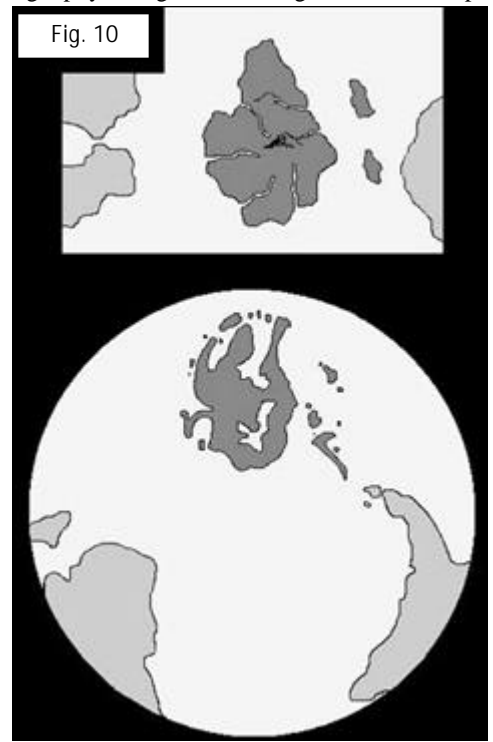

Fig. 10

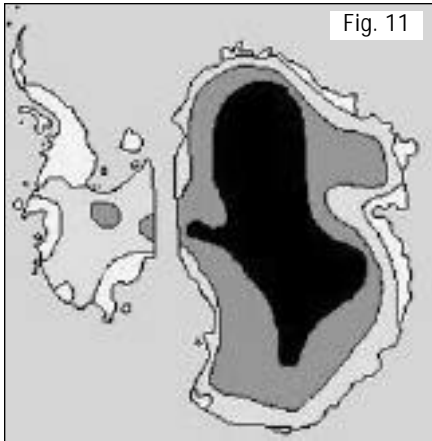

Fig. 11

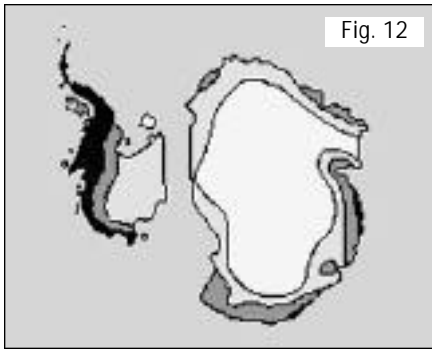

Fig. 12

result of the weight of today's Antarctic ice-sheet. This immense blanket of snow and ice depressed parts of the continent, causing more and more land to fall below ocean level. I believe that the Egyptian map of Atlantis represents in size, shape, scale and position, an ice-free Antarctica.

Now what I've shown you so far is something that I understood for the first time 20 years ago. Plato's account of Atlantis seemed like a crude depiction of the world as seen from Antarctica. I knew I was onto something, but

as I followed the research I encountered the Antarctic ice-cap!

In 1976, the encyclopaedias claimed confidently and absolutely that Antarctica has been under ice for 50 to 60 million years! Now it seemed to me that Plato's account had been amazingly accurate when it came to geography, so I decided to treat the question of the age of the Antarctic ice-sheet as an open rather than closed question. In 1990 I was rewarded when two geologists made a discovery that completely reopened the question of the age of the ice-sheet. Working just 250 miles from the South Pole, the geologists discovered the frozen remains of forest that was later dated to be between two and three million years old.

So it turns out that the encyclopaedias of 1976 were wrong by as much as 58 million years! The absolute, ancient age of the Antarctic ice-cap wasn't so absolute after all.

Most of the ice (nearly two-and-a-half miles thick) lies on what we know as "Greater Antarctica". Darker tones here (see figure 11) represent thicker ice-sheets. On "Lesser Antarctica", the side facing South America and the area corresponding to the island on the Kircher map, the ice-sheet is quite shallow.

I thought perhaps this curious phenomenon could be accounted for by a greater snowfall on Greater Antarctica, but when I turned to the snowfall patterns this is what I found. It's snowing like heck on Lesser Antarctica, the black areas (see figure 12), while over on Greater Antarctica, the area which holds nearly 90 per cent of the world's fresh water, there is virtually no annual snowfall. Greater Antarctica is a polar desert!

There is a dramatic anomaly here. The area of the greatest ice has the least snowfall, while the area of least ice receives the most snowfall. Current snowfall patterns could not produce the ice-sheet that we see today. In this case, the present is certainly not the key to the past. When I looked through the scientific literature trying to find an explanation for this anomaly, I found only silence. There was nothing to be found. Nobody seemed even curious about the fact that the greatest ice-sheet in the world does not have snow falling on it!

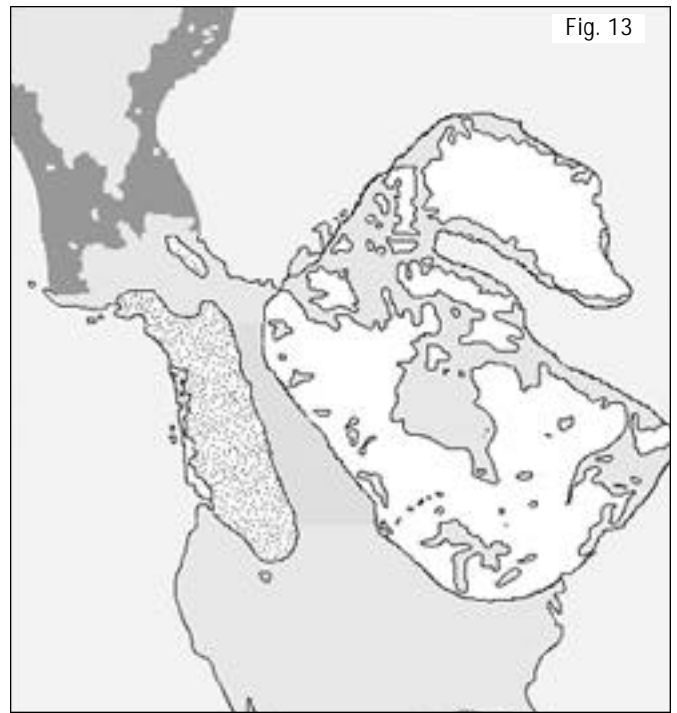

Fig. 13

And when I looked at the northern hemisphere I found a whole host of anomalies. To anyone who has ever visited a museum in North America, this is a familiar map depicting the Ice Age (see figure 13). This is what the continent looked like 12,000 years ago—the time of Atlantis, I might add.

We are told that the native people who first arrived in America came across a land-bridge some 12,000 years ago into a largely ice-free Alaska. From there they made their way through an ice-free corridor that existed between two massive ice-sheets. Notice that the Queen Charlotte Islands were ice-free at this time. This is the homeland of the Haida whose story of a lost city I will be telling later.

There are several problems with the traditional model for the peopling of America. New archaeological sites have been discovered in Chile, Brazil, Pennsylvania and New Mexico which are much older than 10,000 BC. Archaeologists have been slow to accept the implication of these sites: that the people of America have been on this continent long before 10,000 BC. Clearly, the traditional version of how and when people first arrived in America also needs to be re-opened.

Another problem is: why is this ice-free corridor right smack-dab between two massive ice-sheets? And why are the ice-sheets here at all? Why don't they extend to cover Siberia, Beringia and most of Alaska?

I had a lot of questions and I wasn't finding a lot of satisfactory answers in the scientific literature.

Then I read *Maps of the Ancient Sea Kings* by Charles Hapgood and learned that Kircher's map was not alone. There were other ancient maps, including the famous Piri Re'is map, showing Antarctica without ice.

About the Speaker:

Rand Flem-Ath is co-author (with Rose Flem-Ath) of *When The Sky Fell: In Search of Atlantis*, published in 1995 by Stoddart Publishing (Ontario), Weidenfeld & Nicolson (London) and St Martin's Press (New York). (See review in NEXUS 3/01.)

Continued in the next issue of NEXUS...

THE ELECTROLYTIC CARBURETTOR

from Jerry W. Decker of KeelyNet

For years we have heard stories about a demonstration in the Dallas area of a car that ran on water. Never was there any text substantiation or other documents relating details.

Eventually we were sent a short newspaper clipping describing the demonstration. The article indicates a patent was secured for the "something" that made the car run on water.

I finally found a patent issued to Charles H. Garrett on July 2, 1935 and called an "Electrolytic Carburetor". I have been calling it a "Hydrolytic Carburetor" because of what it is combusting, and I am totally amazed at the simplicity of the technology.

Several of our associates have received copies and are quite impressed, and some have gone on to build and test the device. (See KeelyNet website for updates.)

Following is the original article, dated September 8, 1935, that I found on microfilm in the Dallas Library, as well as the text of the Garrett patent.

DALLASITE PATENTS INVENTION WHICH HE CLAIMS SUBSTITUTES WATER FOR GASOLINE AS FUEL

C. H. Garrett, Dallas inventor, gave a private demonstration Saturday of a recently patented contrivance which he said substituted water for gasoline as fuel for internal combustion engines.

He said it broke up the water by electrolysis into its component gases, oxygen and hydrogen, using the highly explosive hydrogen for fuel in the motor cylinder.

The working model operated a four-cylinder engine for several minutes in the demonstration, at varying speeds and with several starts and stops. Garrett said he had operated the engine continuously for more than forty-eight hours.

The inventor said the idea itself was new. He explained that difficulty had been encountered heretofore in attempts to store the dangerously inflammable hydrogen. He claimed to have avoided that trouble by making and exploding the gas in the same process without a storage chamber in which the flames from the motor cylinders might react.

Water, he explained, is broken down into its component gases by passage of an electric current through it from electrodes immersed in the water. Hydrogen collects at the negative pole and oxygen at the positive. The hydrogen, Garrett said, is mixed with air and introduced directly into the cylinders.

The inventor said he had been working on the device for eight years, assisted by his father, Henry Garrett, traffic signal engineer for the city of Dallas, inventor of the traffic signal system, now in use here and holder of several patents on such contrivances.

Garrett said attach -

ment of the electrolytic carburetor and installation of a generator of about double normal capacity to furnish power for the breaking down of the water were the only changes needed to convert a gasoline-burning automobile into a water burner!

He said the electrolysis chamber would have to vary in size with the size of the motor used; one of about a quart capacity being big enough for the ordinary automobile.

He claimed instantaneous starting in any weather, elimination of fire hazards, cooler motor operation and fulfilling of all motor requirements in power and speed.

TEXT OF THE GARRETT PATENT

Patented July 2, 1935 2,006,676

United States Patent Office

Electrolytic Carburetor

Charles H. Garrett, Dallas, Texas

Application July 1, 1932, Serial No. 620,364

This invention relates to carburetors and it has particular reference to an electrolytic carburetor by means of which water may be broken up into its hydrogen and oxygen constituents and the gases so formed suitably mixed with air.

The principal object of the invention is to provide in a device of the character described, a mechanism by means of which water may be readily decomposed into its constituents, and the constituents intimately mixed with each other and with air.

Another object of the invention is to provide means whereby the electrolyte level in the carburetor may be maintained at a more or less constant level regardless of fluctuations in fluid pressure at the fluid inlet of the carburetor.

Another object of the invention is to provide means whereby the relative amount of air mixed with the hydrogen and oxygen may be regulated as desired.

Still another object of the invention is the provision of means to prevent loss of hydrogen and oxygen gases during periods in which these gases are not being drawn from the carburetor.

Still another object of the invention is the provision of means whereby the hydrogen and oxygen resulting from electrolysis may

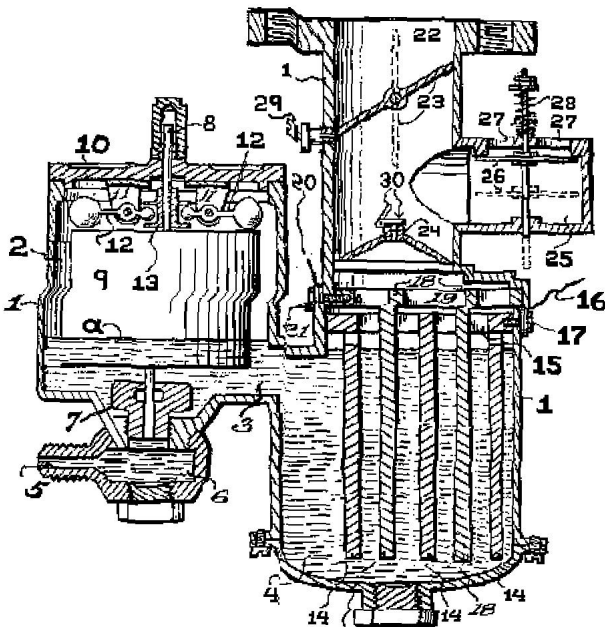
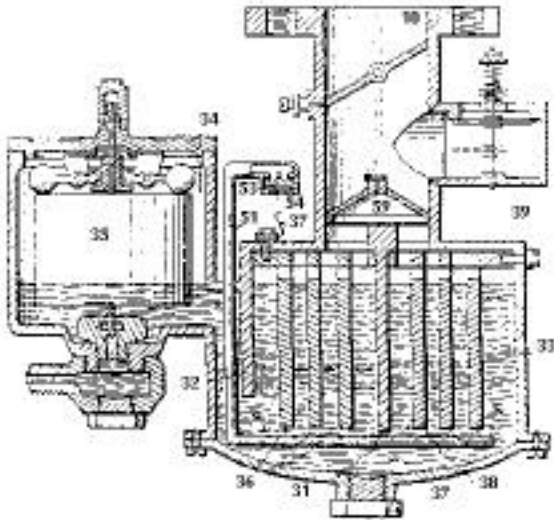

Figure 1: A view in vertical section of one form of carburettor

NEWSCIENCE NEWSCIENCE NEWSCIENCE

Figure 2: View in vertical section of modified form of carburettor



be formed in separate compartments, and a further object of the invention is the provision of means to periodically reverse the direction of current flow and thereby alternate the evolution of the gases in the separate compartments, to be later intermingled.

With the foregoing objects as paramount, the invention has particular reference to its salient features of construction and arrangement of parts, taken in connection with the accompanying drawings...

Continuing more in detail with the drawings, reference is primarily directed to Figure 1, in which the reference numeral 1 designates the carburetor housing which is preferably constructed of bakelite or other suitable insulating material. The housing 1 is so designed as to divide the carburetor into a float chamber 2 and gas generating chamber 4, connected by a fluid passage 3.

Water under pressure is forced into the carburetor through an opening 5 which communicates with the float chamber 2 through the medium of the sediment chamber 6 and the needle valve orifice 7, which is closed by a needle valve 8 when the device is not in operation. A float 9 surrounds the needle valve 8 and is free to move vertically relative thereto. Depending from the cover 10 to the float chamber 2 are two ears 11, located at spaced intervals on opposite sides of the needle valve 8. The members 12 are pivoted to the ears 11, as shown. The weighted outer ends of the members 12 rest on top of the float 9, and their inner ends are received in an annular groove in the collar 13 which is rigidly attached to the needle valve 8.

Within the gas generating chamber 4, a

A gas passageway 22, in which a butterfly valve 23 is located, communicates with the gas generating chamber 4 through an orifice 24. An air inlet chamber 25 has communication with the gas passageway 22 above the orifice 24. A downwardly opening check valve 26 is in control of the openings 27, and is held inoperatively closed by means of light spring 28.

An adjustable auxiliary air valve 29 is provided in the wall of the gas passageway 22, which air valve is closed by the butterfly valve 23 when the butterfly valve is closed, but communicates with the outside air when the butterfly valve is open.

The operation of the device is as follows:

The chambers 2 and 4 are first filled to the level 'a' with a solution of weak sulphuric acid or other electrolyte not changed by the passage of current therethrough, and the opening 5 is connected to a tank of water, not shown.

The wire 16 is next connected to the positive pole of a storage battery

series of spaced, depending plates 14 are suspended from a horizontal member 15 to which a wire 16 has electrical contact through the medium of the bolt 17, which extends inwardly through the housing 1 and is threaded into the horizontal member 15.

A second series of plates 18 is located intermediate the plates 14 and attached to the horizontal member 19, and has electrical contact with the wire 20 through the bolt 21.

or other source of direct current, and the wire 20 to the negative pole. Since the solution within the carburetor is a conductor of electricity, current will flow therethrough and hydrogen will be given off from the negative or cathode plates 18 and oxygen from the positive or anode plates 14.

The butterfly valve 23 is opened and the gas passageway 22 brought into communication with a partial vacuum. Atmospheric pressure acting on the top of the check valve 26 causes it to be forced downwardly, as shown in dotted lines. The hydrogen and oxygen liberated from the water at the plates 18 and 14 are drawn upwardly through the orifice 24 covered by the check valve 30, where they are subsequently mixed with air entering through the openings 27 and through the auxiliary air valve 29.

When it is desired to reduce the flow of hydrogen and oxygen from the plates 18 and 14, the current flowing through the device is reduced, and when the current is interrupted the flow ceases. When the butterfly valve 23 is moved to closed position, the check valve 26 is automatically closed by the spring 28. Any excess gas given off during these operations is stored in the space above the fluid where it is ready for subsequent use.

Figure 3: A diagrammatic view of a pole changer, showing its actuating mechanism

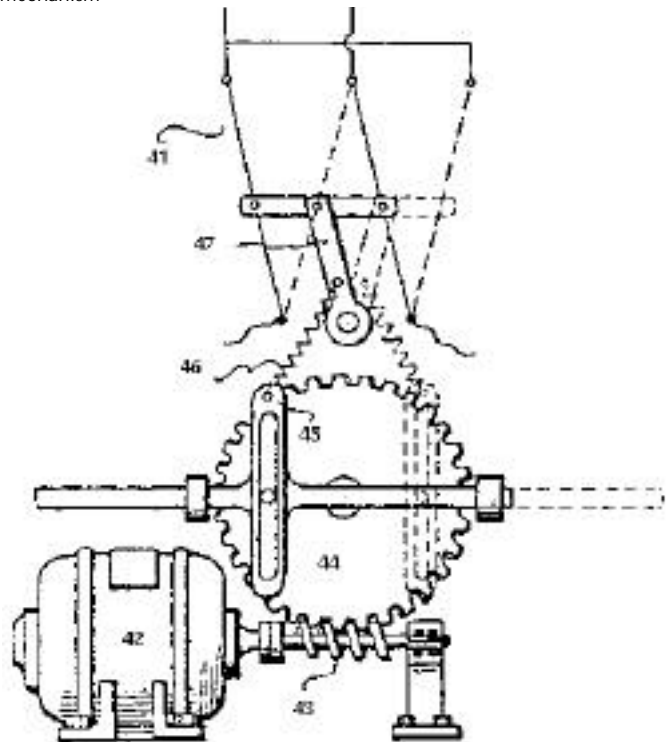

NEWSCIENCE NEWSCIENCE NEWSCIENCE

Water is converted into its gaseous constituents by the device herein described, but the dilute sulphuric acid or other suitable electrolyte in the carburetor remains unchanged, since it is not destroyed by electrolysis, and the parts in contact therewith are made of bakelite and lead or other material not attacked by the electrolyte.

The structure shown in Figure 2 is substantially the same as that shown in Figure 1 with the exception that the modified structure embraces a larger gas generating chamber which is divided by means of an insulating plate 31 and is further provided with a depending baffle plate 32 which separates the gas generating chamber 33 from the float chamber 34, in which the float 35 operates in the same manner as in Figure 1. Moreover, the structure shown in Figure 2 provides a series of spaced depending plates 36 which are electrically connected to the wire 37, and a second series of similar plates 38 which are electrically connected to the wire 39 and are spaced apart from the plates 36 by the insulating plate 31.

Gases generated on the surfaces of the plates 36 and 38 pass upward through the orifice 39a into the gas passageway 40 where they are mixed with air as explained in the description of Figure 1.

A pipe 51 bent as shown in Figure 2 passes downwardly through the housing of the carburetor and has a series of spaced apertures 'a' in its horizontal portion beneath the plates 36 and 38. An upwardly opening check valve 53 is in control of the air inlet 54. When a partial vacuum exists in the chamber 33, air is drawn in through the opening 54 and subsequently passes upwardly through the apertures 'a'. This air tends to remove any bubbles of gas collecting on the plates 36 and 38 and also tends to cool the electrolyte. The check valve 53 automatically closes when a gas pressure exists within the carburetor and thereby prevents the electrolyte from being forced out of the opening 54.

In order to provide for alternate evolution of the gases from the plates 36 and 38, a pole changer 41, shown in Figure 3, is provided, which is actuated periodically by the motor 42 which drives the worm 43 and the gear 44 and causes oscillations of the member 45 which is connected by a spring 46 to the arm 47, thereby causing the pole changer to snap from one position to the other.

In operation, the carburetor shown in Figure 2 is connected as shown in the wiring diagram of Figure 4. A storage bat-

tery 48 or other suitable source of direct current is connected to a variable rheostat 49, switch 50, pole changer 41 and to the carburetor, as shown. Thus the rate of evolution of the gases can be controlled by the setting of the rheostat 49, and the desired alternate evolution of the gases in the compartments of the carburetor is accomplished by means of the periodically operated pole changer 41.

Manifestly, the construction shown is capable of considerable modification, and such modification as is considered within the scope and meaning of the appended claims is also considered within the spirit and intent of the invention.

What is claimed is:

1) An electrolytic carburetor including an anode and a cathode, float-means to control the level of the electrolyte within said carburetor, means to mix the gases resulting from electrolysis with air, and a check valve independent of said float-means to control ingress of air to said carburetor.

2) An electrolytic carburetor including anode and cathode plates, a float-actuated valve in control of the electrolyte level within said carburetor, means to mix the gases resulting from electrolysis with air, a check valve in control of said means, a second check valve independent of said float-actuated valve to prevent loss of gases from said carburetor.

3) An electrolytic carburetor for producing mixtures of hydrogen, oxygen and air, including a series of spaced and electrically connected anode plates partially immersed in the electrolyte within said carburetor, a series of electrically connected cathode plates spaced between said anode plates, a float-operated valve in control of the electrolyte level within said carburetor, an air inlet to said carburetor and a check valve in control of said air inlet.

4) An electrolytic carbure-

tor for generating hydrogen and oxygen gases from water and for mixing said gases with air, including an anode and cathode partially immersed in an electrolyte within said carburetor, float-actuated means to replace the water consumed whereby to maintain a constant fluid level within said device, means for mixing the said gases with air, and a check valve in control of said latter means.

5) An electrolytic carburetor including an anode and a cathode, float-actuated means to control the level of the electrolyte within said carburetor, means to mix the gases resulting from electrolysis with air, a check valve in control of said latter means, and means to periodically reverse the direction of current through said carburetor.

Charles H. Garrett

CAVEATS AND SAFETY WARNINGS

Hydrogen is **EXPLOSIVE** and is **INVISIBLE** when it is burning!

We here at Vanguard Sciences/KeelyNet and our Associates believe in and practise the free and open release of information relating to energy production, health and gravity-control technologies.

If you choose to experiment with this device, we urge you to be extremely careful. We would greatly appreciate your findings or comments and perhaps, with many minds and approaches, this can yet be a viable project.

(Source: Jerry Decker at Vanguard Sciences/KeelyNet, www.keelynet.com; first posted 3 Dec 1993, updated Feb 1998)

Figure 4: A wiring diagram for the modified form of carburettor shown in Figure 2.

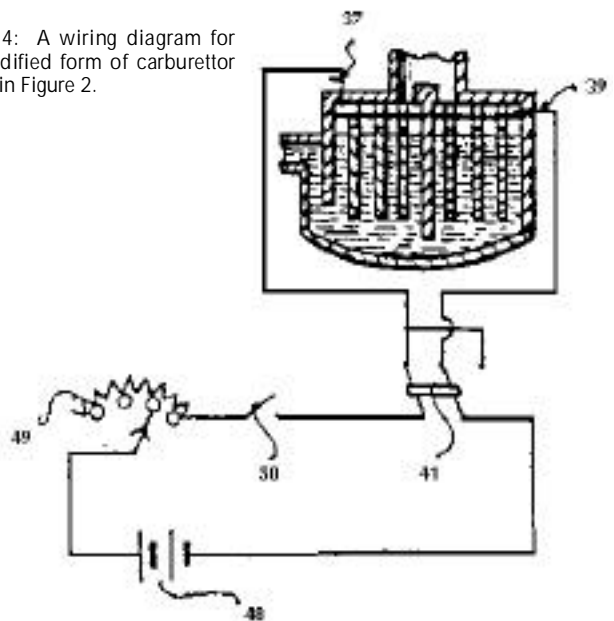

Inside Revelations on the UFO Cover-up

A high-level scientific/medical specialist working with the military/intelligence agencies, Dr Michael Wolf has been privy to secrets about UFOs and ETs, and can now make some of this information public.

by Richard Boylan, PhD, LLC © 1998

2826 O Street, Suite 2
Sacramento, CA 95816, USA
Telephone: +1 (916) 455 0120
E-mail: Rich.Boylan@24stex.com

Dr Michael Wolf is a 56-year-old man pincered between the horns of a quintessential dilemma. His bosses at the National Security Council (NSC) have told him that they want him, precisely as a government scientist with ABOVE TOP SECRET clearance, to generate a controlled leakage of major amounts of secret information. That information is about UFO reality and extraterrestrial contact with humans, including governmental involvement. On the other hand, they have told him not to disclose too many government secrets, nor too many details about his role inside ULTRA-classified projects. (He characterises his current low-profile status as "sequestered".)

To complicate matters further, his bosses have "erased" almost all his records, such as the universities he attended, his degrees and his record of government service as an independent contractor to the Central Intelligence Agency (CIA), the National Security Agency (NSA) and the NSC. Such measures are common for individuals working in Unacknowledged Special Access Programs, where their bosses must maintain "plausible deniability" in case a "sensitive" worker decides to make unauthorised disclosures. Additionally, the national security oath Wolf had to sign required that he could not publish papers in scientific journals on his classified research findings.

As a result, Dr Wolf can hardly prove he exists. But, as a very brave person, Wolf has decided nevertheless to keep on revealing secrets until his superiors tell him to stop. America and the world are indeed fortunate that he has made that decision.

Dr Wolf decided to reveal to the world what he has learned about the visiting extraterrestrial cultures because, as he said, "we have a right to know". He is also motivated by the need to feel that he is making a contribution to humanity for his wife, son and unborn child who were assassinated in a terrorist car-sabotage "accident" meant to kill him as well. He admits that hindsight has caused him to re-evaluate the importance of keeping secret all the things he has worked on.

His efforts to persuade his bosses to let him publish and speak have met with some success. His book, *The Catchers of Heaven*,¹ was approved for publishing, but only after he met their restriction that he write a foreword stating that it was "a work of fiction". The book is filled with insider disclosures and is must-reading for anyone interested in learning more about the extraterrestrial presence. Dr Wolf is currently working on a sequel, *Bright White Light Quartet*, which will provide further information about his personal experience with the extraterrestrials, their communications and their missions.

I have been authorised by Michael Wolf to share publicly, in this article, the disclosures he has made since *Catchers* was published. This report will not duplicate my earlier article on Dr Wolf.² Also, these disclosures come from notes I scribbled furiously as I tried to keep up with Dr Wolf's machine-gun pace of talking. Like many geniuses, he moves from topic to topic rapidly, not leaving the interviewer an opportunity to get certain details. The reader will just need to make do for now with what was captured in my notes, and forgive the sometimes missing details that occur in that kind of communication. Any mistakes are mine.

I can well understand that some of the partial disclosures here leave the reader hungering for more detail. Such is the current state of affairs at this point in the US Administration's guarded-disclosure/plausible-denial strategy, a complex dance of opposites. Yet, in unprecedented volume and depth, secrets are emerging from deep inside the most jealously guarded and denied programs the US Government runs: its UFO programs—presented here, courtesy of Dr Wolf.

But who is this man who discloses such tightly held information? Michael Wolf's

ancestors were Russian Jews who emigrated to the US and adopted the family name of Krivant. Even as a child, Michael was no stranger to the classified world nor to encounters with an extraterrestrial. He would accompany his father to Andrews Air Force Base while he met with the Air Research and Development Council. Indeed, Michael was not the first in his family to experience contact with what he calls "my little Grey navigator, an undisguised blessing". Michael's father had been visited by Grey ETs, too, and had spoken to Michael various times about those "Catchers of Heaven", as he called them. And Michael's future son, Daniel, would also be an experiencer of ET encounters.

By the time he was twelve, Michael was taking characteristic initiative. He founded the Flying Saucer Research Association of New Jersey. At night he tried communicating with his extraterrestrial friends, using light signals. On 24 December 1954, one such effort was observed by George Hunt Williamson (identified by Dr Wolf as having been a CIA operative). Williamson, in his book, *Road in the Sky*, wrote that young Wolf, the year before his *bar mitzvah*, was transmitting messages to space intelligences using modulated light beams. Michael had telepathically requested that the ETs confirm receipt of his mental message by flying over his house in a certain direction. Wolf recalls: "Five minutes later, two flying saucers flew over my house, heading north, as I had requested."

The intelligence community began to keep tabs on Wolf and eventually recruited him. Wolf recounts that the government guided and paid for his impressive education because they saw he had a good relationship with the ETs and because he was the brightest student his teachers had seen.

Dr Michael Wolf served in the Vietnam War era as an Air Force colonel, pilot and flight surgeon, and as an I-Corps intelligence officer for the CIA and NSA. He has earned an MD in neurology, a PhD in theoretical physics, an ScD in computer science, a JD in law, an MS in electromagnetic influences on organisms and a BS in biogenetics.

Basically a Buddhist, Wolf also affirms the core truths in Islam, Christianity, Judaism, Native American spirituality and other

major spiritual traditions. His personal seminal koan: "The truth is a lie which has yet to be revealed."

From 1972 to 1977 Dr Wolf was engaged in covert governmental research into extraterrestrial technology. "I met with extraterrestrial individuals every day in my work, and shared living quarters with them"—while doing research at extremely classified underground government research laboratories. "Zetas work in underground facilities, as requested by the US Government. The ETs are not breaking the US Government-Zeta treaties, but the Government has broken treaties by mistreating ETs and trying to fire on UFOs." Yet there are some extraterrestrials being held captive. "Government scientists discovered that the ETs cannot dematerialise and escape if there is an extremely powerful electromagnetic field surrounding them." (By way of corroboration, I have heard a government contractor describe three-foot-thick walls, with many wires embedded and running through them, at Haystack Air Force Laboratory.)

Dr Wolf commented: "Some in the government want better diplomatic relations [with the ETs], but others in the military want to shoot them down." This is ironic, Wolf said, "because SDI [Star Wars] technology was given to the government by the ETs".

Laboratories where he worked include S-4 (near the northeast corner of the Nevada Test Range) and nearby Area 51 (where he lived for a while), the Foreign Technology Division labs at Wright-Patterson Air Force Base (Dayton, Ohio), and the former Dulce Laboratory (near the New Mexico-Colorado border). Wolf says he is also aware that extraterrestrials work with government scientists at Haystack Air Force Laboratory, deep under Haystack Butte at Edwards Air Force Base, California. And when the subject was brought up of the complex at Indian Springs Auxiliary Air Field adjacent to the Nevada Test Site, Wolf quickly responded: "I can't say anything about that."

Since 1979 Dr Wolf has served as a scientific consultant to Presidents and the National Security Council on extraterrestrial matters. He is also a member of the NSC's unacknowledged UFO information management subcommittee's (MJ-12's) panel of scientists. "The code-names I used there were 'Griffin' and 'Nu Kappa Eta'." MJ-12 made Dr Wolf the Chairman of Alphacom Team, its premier extraterrestrial-matters group which also includes an admiral from naval intelligence.

Wolf observes that the generals he worked with feel impotent in the face of the overwhelming superiority of extraterrestrial technology and mental abilities. Because of those feelings of powerlessness, anathema to military officers, the generals authorised an intense and extensive disinformation campaign (the UFO cover-up) to discourage any attempts by civilians to acquire even the limited understanding of extraterrestrials which the generals had managed to gain.

A far more disturbing revelation from Dr Wolf concerns the existence of a renegade group within the military and intelligence agencies involved in the UFO cover-up. Wolf has labelled this conspiratorial group of plotters "the Cabal". Made up of extremist, fundamentalist, xenophobic, racist and paranoiac officers, the Cabal fears and hates extraterrestrials. And, without any presidential or congressional authorisation, the Cabal has commandeered Star Wars weaponry to shoot down UFOs; it has taken surviving extraterrestrials prisoner and attempted to extract information by force. A high-level military officer, who is considered a "friendly" by the Cabal but who secretly dislikes it, passes on information about Cabal planning and activities to Dr Wolf.

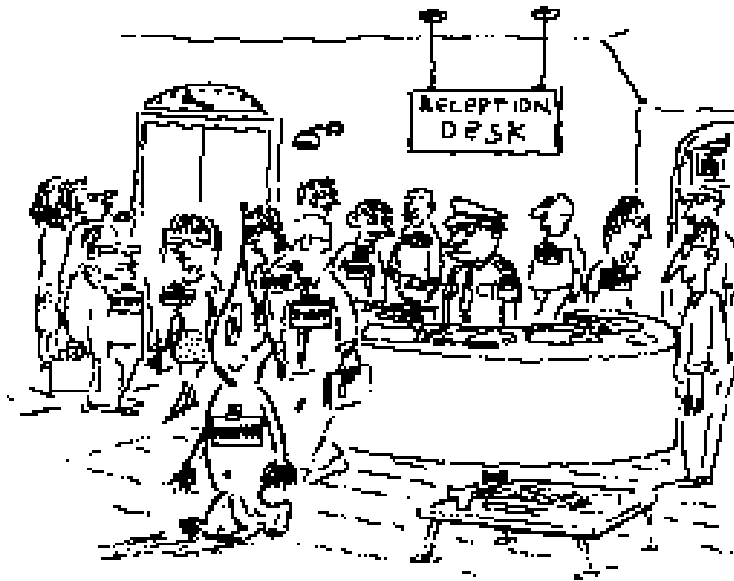

The Cabal "controls" some well-known UFO investigators. Wolf says that the director of one major US civilian UFO organisation "is up to his ass in the Cabal". And he adds that another ufologist in Canada "gets paid for taking swipes at various UFO researchers". That ufologist's high reputation for UFO research is undeserved because he was getting a stream of leaks and tips from a well-placed official inside the intelligence community, thus he knew precisely what UFO data to look and ask for. That ufologist now gets frequently upset because his source "inside" is no longer available, having died recently.

As a presidential consultant, Dr Wolf has visited Mr Clinton in his White House private chambers, and he even dropped the remark that "Mr and Mrs Clinton sleep in the same bed", thus scotching rumours to the contrary. When Mr Clinton was visiting Hartford, Connecticut, for a presidential debate, the presidential candidate took a side trip to consult with Dr Wolf. And to this day, Wolf continues to provide advice to the President by encrypted phone and National Security Council courier. Possessing some of the highest security clearances, this man is in an extremely qualified position to know what the government knows about UFOs and ETs. He says he wants to tell President Clinton everything—"but I can't; my [NSC] bosses won't let me".

Wolf says that "President Clinton does not know much about Area 51; and he does not know about S-4"—the super-secret underground installation 13 miles south of Area 51 at Papoose Lake where Dr Wolf did some of his research. "The President has ABOVE TOP-SECRET and Need To Know clearances, but does not have the UMBRA ULTRA TOP SECRET clearance to have access to upper-level MAJIC [MJ-12] secrets and KEYSTONE [ET research] documents," Wolf adds.

Like many federal bureaucracies, MJ-12 has tripled in size, Wolf reports. "It now numbers 36 members, including [former Secretary of State] Henry Kissinger and [father of the hydrogen bomb] Edward Teller. MJ-12 meets at various confidential locations, including the Battelle Memorial Institute [at Columbus, Ohio]." As an aside, Dr Wolf confirms that it was Dr Edward Teller who recommended physicist Robert Lazar for his position at the secret S-4 government base south of Area 51, where Lazar helped on back-engineering the propulsion systems of extraterrestrial spacecraft.

When I asked who was MJ-1, the head of the MJ-12 subcommittee, Dr Wolf declined to identify that person. He did say: "MJ-1 answers to no one, not even the President." When I offered the surmise that Michael Wolf himself was yet another MJ-12 member, he hurriedly pointed out that he "could not disclose such a thing". And when I proposed that a notable scientist with a government background, residing in Arizona, was yet another MJ-12 member, Wolf responded with an uncharacteristic silence, which I took to mean that he did not contradict that identification.

Michael Wolf has formed acquaintanceships with renowned top scientists working on cutting-edge science. One such scientist is Dr Hal Puthoff, whose research includes zero-point energy which may replace petroleum to provide a clean source of the world's power. Wolf worked on remote-viewing research for the government at the same time that Puthoff was doing so at Stanford Research Institute. Darrell McMillan of the Union of Concerned Scientists is another scientist Wolf says he knows, as is Dr

Stephen Hawking, the British theoretical astrophysicist.

Dr Wolf asked me if I had seen the recent movie, *Peacemaker*. When I replied that I had, he said: "The woman in that movie was based on a real person I worked with—Dr Jessica Stern of the National Security Council."

And, of course, he has met Dr Edward Teller. Wolf characterises Teller as "a nuclear humbug", referring to Teller's deception of making a presentation to President Reagan about an X-ray laser Star Wars weapon being almost operational when in fact the system had never been tested. Indeed, the system was subsequently discarded as impossible by other Lawrence Livermore Laboratory scientists.

Another UFO notable with whom Wolf is familiar is Admiral Bobby Ray Inman, former head of the NSA and currently Chairman of Science Applications International Corporation (SAIC). SAIC was identified by USAF Colonel Steve Wilson as the company which makes antigravity engines for US "copycat UFOs". When I commented to Dr Wolf that USAF Colonel Wilson had identified Inman as also in charge of Decision Science Applications, Inc. (DSAI)—made up of the heads of corporations

involved in classified military weapons development based on ET technology—Wolf said: "Inman doesn't know as much as the UFO community thinks he does. He doesn't know everything that DSAI is up to."

Wolf also verifies that the former head of the Air Force Special Forces' Project *Pounce* (UFO retrievals unit), Colonel Steve Wilson, and Air Force Technical Sergeant/NSA analyst Dan Sherman, assigned to an NSA unit conducting telepathic

communications with the ETs, *are* who they say they are.

The Cabal "controls" some well-known UFO investigators. Wolf says that the director of one major US civilian UFO organisation "is up to his ass in the Cabal".

Dr Wolf provided a revisionist history about the beginning of the modern UFO era. "The first UFO came down in 1941, into the ocean west of San Diego, and was retrieved by the navy." The US Navy has held a leadership position in UFO matters ever since.

A more famous UFO crash followed in 1947, northwest of Roswell, New Mexico, and the craft was retrieved by the Army Air Corps, as reported by Colonel Corso in his book, *The Day After Roswell*.

Dr Wolf confirms the truth of Colonel Corso's disclosures, and notes that LEDs (light-emitting diodes) and superconductivity are among the technologies which came from Roswell. The US was in possession of a Grey alien, dubbed "EBE" (extraterrestrial biological entity), from 1948 until his death in 1953. Government scientists first communicated with him using pictographs. About the alien-threat tone in Corso's book, Wolf comments that "it was co-author William Birnes who did the anti-alien gloss on Corso's manuscript", and that Colonel Corso himself did not view the extraterrestrials as enemy invaders.

Within months of the Roswell UFO crash, the US Army Air Corps became the Air Force; the National Security Act was passed, partly to deal with the extraordinary secrecy the Administration felt UFOs required; and the CIA was created.

Dr Wolf personally pioneered a mental expansion process he calls "the Gateway Treatment" which "allows utilisation of a vastly increased percentage of the brain in order for humans to men-

tally engage the extraterrestrials in full telepathic mental exchange". The Treatment involves "a way of opening the brain up, a way to stimulate the neurons; it allows billions of synapses to form".

Another project Wolf was involved in was subatomic particle physics research. He says his discoveries were "utilised" by his PhD dissertation—advising professor "to develop the neutral particle-beam weapon for the Star Wars program".

Drawing on information from his work in genetics research, Dr Wolf reveals that the entire human genome has been mapped secretly by government scientists. (This contradicts current government press releases which describe the completion date as early in the next century.) He says he has found an extraterrestrial marker gene in some humans' genetic samples, but that other humans do not have these ET marker genes. Further, he says: "I have found non-coding [extraterrestrial] genetic sequence genes in my own genetic material, more than the In-Betweens have." ("In-Betweens" is Wolf's term for humans with hybrid ET-human genetics, due to ET intervention with their parents' reproductive material before they were born.) Wolf also reveals he has been around a research project where government scientists created human-extraterrestrial hybrids, attempting to replicate ET genetic engineering.

He explains that the harvesting of tissue from so-called cattle mutilations "is to prepare organelles to adapt to human bodies, to filter out particulates that are killing us as we pollute our planet". He says, "The 'Betweens' [human-ET hybrids] will help us and will bring the organelles."

The ETs have other concerns, too. They discussed God and death with Wolf. And they pointed out that all worlds are connected: "One Hiroshima atomic bomb can affect millions of cultures in the galaxy." They also told him: "Thought is energy. It doesn't stop at a galactic 'barrier'—it is received on other worlds."

Because of what he has learnt, Wolf now says: "We are at a crossroads. The issue is to give a viable future to our children." He also notes: "Humans are beginning to change, to evolve, and are looking for spiritual roots. There is more to God than people get in church."

A fourth ultra-secret project mentioned in Wolf's book was a Department of Defense project having to do with cloning a human being in order to create the perfect soldier who would obey orders without question. A General Bunting was in charge of that project. The clone turned out to have been born with ethical thinking and the intuitive knowledge that life is sacred. Wolf says that when the clone disobeyed a test order to kill an innocent dog, "the project officer ordered the clone 'terminated'". It was his judgement that "the clone had a soul"; so, instead, he "blew up the building" containing the clone project and surreptitiously allowed the clone to escape.

Naturally, Wolf keeps aware of significant individuals and developments within the civilian UFO-investigation community. One such figure is former Army Command Sergeant-Major Robert Dean who was assigned to NATO Headquarters in the 1960s. There, Dean read NATO's secret Assessment of extraterrestrials. Wolf says that he has "seen that same Assessment".

Dr Wolf reveals that "the NSA and CIA regularly provide the members of MJ-12 with tapes of major meetings of civilian UFO groups"—for example, MUFON conferences.

He also mentions that some of the notable UFO investigators who have talked with him include Robert Bletchman, James Courant, Linda Moulton Howe, William Hamilton, Michael Hesemann and Dr Steven Greer.

Some years ago, documents were leaked purporting to constitute a presidential briefing for President Jimmy Carter on extraterrestrial matters. Dr Wolf affirms that the information contained therein "...is substantially true, but one page was missing from the leaked set. That page describes an individual of joint ET-human heritage who emerged two thousand years ago to try to end human violence." When I proposed that the page was referring to Jesus, Wolf confirmed that identification.

Dr Wolf describes various extraterrestrial races. "One race has orange skin, very large heads and large dark eyes with no irises or whites, and six-fingered hands. During dissection their brains

have been found to have four brain lobes, different optic orbs and nerves, and a sponge-like digestive system. ET brains are more developed and connected, and have no corpus callosum." He also describes a race dubbed "the Semitics", of average height and a generally humanlike appearance except for their very large, hooked nose. "This was the race which landed at Holloman Air Force Base [New Mexico, in the 1960s] and conversed with some generals there." Wolf also describes a very human-appearing race called

"the Nordics". "The Semitics and Nordics come from Altair 4 and 5 and from the Pleiades."

Dr Wolf also notes: "The extraterrestrials eat vegetation and mushrooms and have different requirements. They absorb energy from the air and [certain] particulates. They don't absorb enough water to need to void; they process thoroughly." He says that "cattle mutilations" tissue harvesting is not related to cloning, but rather is done to acquire nutrients for the hybrid foetuses the ETs create, and he notes that embryonic fluid contains an anti-rejection factor. He is also aware that not all cattle tissue harvesting is done by extraterrestrials; some is done by Special Forces teams.

Wolf says that crop circles "were originated by extraterrestrials and then badly copied by the military using Strategic Defense Initiative weapons emitting a laser-pulsed beam". He also notes: "...with crop circles made by ETs, the plants were still alive and grew [after being bent into pictographic patterns]. With SDI-weapon crop circles, the plants die. These SDI weapons are operated from a secret base in the Himalayas."

Concerning extraterrestrial contact, Dr Wolf states that the ET race commonly referred to as the "Zeta Reticulans", or "Greys", has engaged in diplomatic negotiations with the US Government.

When I asked him which extraterrestrial races he worked with in government labs, he pointed out that the two illustrations on the front and back covers of his book, *The Catchers of Heaven*, are actual photographs of extraterrestrials taken by an admiral friend of his. The ET on the front cover is named "K*L*T", which Wolf phoneticises to "Kolta" for convenience, and is the Zeta Grey extraterrestrial with whom Wolf has met most frequently. The ET on the back cover is a human-appearing Pleiadean named "Anon [Prince] Sa Ra".

Drawing on information from his work in genetics research, Dr Wolf reveals that the entire human genome has been mapped secretly by government scientists.

In the course of his close association with extraterrestrials in scientific laboratories, Dr Wolf was given a piece of extraterrestrial metal. This metal looks like melted silicon and has peculiar energy properties. It is 99.99 per cent silicon, with 0.01 per cent non-Earth isotopes. He says that when he placed the metal in water and drank the water, it provided healthful benefits.

Wolf is convinced that it was psychotronic directed-energy devices that were used by rogue elements within the UFO cover-up organisation against certain UFO researchers pushing very strongly to end the UFO cover-up. These researchers include: the Director of the Committee for the Study of Extraterrestrial Intelligence (CSETI), Steven Greer, MD, and his principal assistant, Shari Adamiak; Congressman Steve Schiff who demanded UFO documents from the Air Force; and USAF Colonel Steve Wilson who revealed his heading Project *Pounce*, the UFO retrieval unit. Already, Colonel Wilson and Shari Adamiak have died of their cancers and Congressman Schiff has had to terminate his political career. And now Dr Wolf has received a medical report which suggests a possibility that he may have cancer. It is not yet clear whether he still has access to a certain extraterrestrial honeylike substance that he took several years ago for his metastasised colon cancer, thus bringing it into remission.

Concerning the famous 1947 Roswell UFO crash, Wolf states that "it was actually two UFOs which collided in mid-air" during an intense electrical storm. "One contained Orange ETs, and the other, Greys." One craft crash-landed near Corona, northwest of Roswell; the other crashed onto the Plains of San Agustin, over a hundred miles to the west. Army intelligence units soon secured both sites and removed the craft and their mostly dead ET crews.

Another later ET-military encounter recounted by Dr Wolf is similarly grim. "An extraterrestrial on the ground had travelled from Fort Dix, New Jersey, to nearby McGuire Air Force Base where he died on the tarmac."

Michael Wolf worked in several projects where he made discoveries which, in hindsight, he now regrets being involved with. He particularly had misgivings after he saw what applications these discoveries were put to. He says he now has "immense qualms about those misapplications"; he repudiates them and is repentant for them.

When Dr Wolf was engaged in government-sponsored studies for his MD degree at McGill University, he carried out research on neurotransmitters and their role in mental functioning and control. Among the secret projects Dr Wolf worked on was "remote viewing"—a military-intelligence term for "applied clairvoyance". He says: "Ninety-nine per cent of telepathy and remote-viewing research is classified."

Wolf says he went far beyond the crude Army Intelligence psi experiments of General Bert Stubblebine, Lt Colonel John Alexander and Major Ed Dames: he developed memory extraction and memory "capping" (suppression) techniques. Some of his findings "were later incorporated into the infamous *MK-Ultra*

mind-control projects of the CIA, and used on captured KGB agents" to extract information. He also worked in research on dolphins—"a highly-intelligent alien life-form on this planet".

While Dr Wolf was studying at MIT for his PhD in physics, he "discovered a new theory of wave-particle duality which led to the development of the neutral particle-beam Star Wars weapon".

Because of these classified projects, Wolf's NSC bosses forbade him to identify his dissertation-advising professor, and MIT and McGill are forbidden to acknowledge that he studied there.

Having access to NSA and CIA information, Dr Wolf also reveals some secrets in which he was not involved. One, among the ugliest aspects of the Vietnam War, was the US's Project *Arc Light*—"the bombing of already-shot-down B-52s with 'Hellfire' incendiary bombs, totally incinerating any survivor crewmen, in order to destroy the secret documents carried on the B-52s". President Bill Clinton told Michael Wolf that he had learned about Project *Arc Light* while a student in England and that it had deepened his opposition to the Vietnam War.

Wolf also learned that the assassination of President Kennedy involved multiple parties and interests. "Many Cuban expatriates hated Kennedy for the Bay of Pigs invasion's failure. The Mafia

hated JFK because of his brother, Attorney-General Robert Kennedy's relentless prosecutions of high-level mobsters. Hardliners in the CIA hated Kennedy because he wanted to pull the US out of an escalating war in Vietnam and because he wanted the CIA to disclose UFO information."

Wolf discloses that famed scientist "Albert Einstein had contact with extraterrestrial intelligence", and that a more recent understanding of zero-point energy "has to do with a white hole/black hole scenario". He says the ETs told him that the void is filled with energy to be tapped. Further, he states that experiments by the US Government using exotic technology "ripped holes in time".

Wolf worked briefly on assignment to the Mossad, Israel's intelligence organisation. "The Mossad has very good relationships with the extraterrestrials," he comments.

Dr Strecker's published research report, identifying HIV/AIDS as caused by a manmade virus, is correct according to Dr Wolf. Furthermore, the government has learned that viruses are crystalline in structure and that the correct frequency can destroy them.

Wolf reports that "President Clinton has had a briefing on the *Aurora* [SR-33A] space plane" which operates out of Area 51. The *Aurora* "runs on liquid methane and has antigravity on board"—information identical to what retired Air Force Colonel Donald Ware passed on to this writer from a three-star general. Wolf said that the *Aurora* goes the *Stealth* planes one better. "It carries an electromagnetic pulse weapons system on board which can knock out tracking radar." He also discloses: "It can go to the Moon!". And he adds a tantalising hint that "the US has 'something' on Mars" besides the *Rover*.

Wolf reveals that the US Government is working on prototypes of extraterrestrial antigravity discs. He says that the extraterrestrials traverse the galaxy by manipulating space and time to pull

In the course of his close association with extraterrestrials in scientific laboratories, Dr Wolf was given a piece of extraterrestrial metal.

This metal looks like melted silicon and has peculiar energy properties. It is 99.99 per cent silicon, with 0.01 per cent non-Earth isotopes.

their destination towards them. "Time is reduced to zero, and acceleration is increased to infinity." He also says that the military is experimenting on having pilots use their mind to guide an advanced plane. Some government scientists have found that "some UFOs are living conveyances and can divide and re-form". Those "living conveyances" are apparently also responsive to thought commands.

Wolf discloses an incident that occurred on the Caribbean island of Puerto Rico during the Bush Administration. "A UFO piloted by extraterrestrials, with F-16 fighter escort overhead, landed in a Puerto Rican city in 1990. The purpose of this exercise was to test the public reaction of a select portion of the American people." (Puerto Rico is US territory.) The mayor of the city contacted President Bush, excitedly told the President that "extraterrestrials got out of the ship and walked around", and asked Bush what he should say to his citizens. Bush referred the inquiry to Dr Wolf at MJ-12 to formulate a response for the mayor.

Concerning the US Government's slow pace of disclosure about UFO reality, Wolf comments: "The government is doing a balancing act because if free [zero-point] energy and all the ET technology came out all at once it'd hurt the stockholders [in obsolescent industries]. The multinational corporations don't want to lose their power." The last time Dr Wolf heard, the timetable from the government for frank disclosure of UFO reality is somewhere in the period of 2001 to 2005.

For all his education and unique career, Dr Michael Wolf is a generally modest man. He lives alone in a simple urban apartment and still grieves over the tragic deaths of his wife and son Daniel, lost years ago. Facing twin terminal illnesses of spinal

degeneration and a wasting disease, he is dedicated now to trying to help create a better world for the children. "The children are the future," he says, and to this end he has directed that all royalties from his books go to the Daniel Wolf Memorial Foundation For Children, Inc., a non-profit 501(c)(3) organisation.

Dr Wolf looks forward to when the secrecy about extraterrestrial contact with Earth is stripped away, so that we, our children and grandchildren can move forward to the next phase of our history, now cosmic in scale.

Endnotes

1. Wolf, Michael, *The Catchers of Heaven: A Trilogy*, Dorrance Publishing Co., Inc., Pittsburgh, Pennsylvania, USA, 1996, ISBN 0-8059-3907-5. (See review in NEXUS 4/06.)
2. Boylan, Richard, "Officials within UFO Secrecy Management Group Reveals Insider Secrets", *Contact Forum*, vol. 5, no. 5, September-October 1997.

About the Author:

Richard J. Boylan, PhD, LLC, is a behavioural scientist, clinical hypnotherapist, consultant and researcher who recently retired from his 25-year practice as a psychotherapist and clinical psychologist. He presented papers on his research at the 1992 MIT Abduction Study Conference and at the 1995 Cosmic Cultures International Conference in Washington, DC.

Dr Boylan is the author of over 30 articles and four books, *Extraterrestrial Contact and Human Responses* (1992), *Close Extraterrestrial Encounters* (1994), *Labored Journey to the Stars* (1996) and *Project Epiphany* (1997).

Editor's Note:

Dr Wolf does not give out his contact details, but readers may write to him through his publisher, Dorrance Publishing Company, Inc., 643 Smithfield Street, Pittsburgh, PA 15222, USA; ph (412) 288 4543, 1-800 788 7654, fax (412) 288 1786.



SECRET TUNNELS OF THE GIZA PLATEAU

An Interview with Boris Said
by Kenneth and Dee Burke
of Leading Edge Newspaper

Boris Said took part in writing and producing the Emmy Award-winning NBC-TV feature documentary, *The Mystery of the Sphinx*, hosted by Charlton Heston.

The documentary focused on the

research of John Anthony West, which suggests that the "water weathering" on the Sphinx indicates it is much older than previously believed.

Boris also produced a documentary, *Secret Chamber*, about the alleged room under the Sphinx, identified during research for *Mystery of the Sphinx*.

Before becoming a documentary filmmaker, Boris was a champion auto-racer and the US bobsled team driver in three Olympic Games.

some well-meaning and some not-so-well-meaning people who are trying to get to the bottom of the Atlantis legend.

Specifically, my ex-partner John Anthony West, as well as Robert Bauval and Graham Hancock who have both written wonderful books, basically succeeded in alienating most of the management of the Giza Plateau—Dr Zahi Hawass and his associates in the Egyptian Antiquities Organization. These three researchers have got themselves locked off the plateau. There has been a lot of acrimony, accusation and name-calling. The bottom line is that they have pretty much been locked out of any kind of investigation.

What developed out of that was a conspiracy theory—which my good friend Richard Hoagland added to—with this discovery of an illicit tunnel in the [Great] Pyramid. The tunnel is allegedly heading for a room at the end of an air shaft—which was discovered by a German robotic camera, operated by Rudolf Gantenbrink who was also ultimately asked to leave the plateau.

I have been filming over there since 1991. I have never been denied access to anything, so if there is a secret tunnel in the chambers above the King's Chamber, then why would they have given me, on two occasions, permission to take a television crew up there? We have had cameras all



Leading Edge Newspaper (LE):

Our readership will be interested in the kind of presentation of your material that you are planning to give at the February [1998] Global Sciences Congress in Florida, USA.

Boris Said (BS):

What I plan on doing at the Global Sciences Congress is to debunk some of the mystique that has been built up around Egypt and the Giza Plateau by

THE TWILIGHT ZONE

over the Pyramid, and we have never been denied access or given only restricted access. But my feeling is, if you look at the plateau honestly and objectively, there are some amazing things going on.

I don't believe that there are conspiracies. There is, however, a lot of spirited competition to see who gets to announce what, and I believe that my friend, Dr Zahi Hawass, is at the forefront. He is the person who announces all the discoveries and all of the finds. He does not like the idea that foreign investigators come to Egypt to 'exploit' the treasures of Egypt. I think he sees Hancock, Bauval and John Anthony West as exploiters. I don't share that view, but I try to stay out of the line of fire, primarily because they have not precluded me from doing anything over there.

LE: So your focus in Egypt is what? We know that you were involved in producing the NBC-TV special, *Mystery of the Sphinx*, with John Anthony West.

BS: Yes, and since then I have put out a video with pieces of the mystery of the Sphinx and pieces of some other work that we did. I was over there for two years working in conjunction with a group called the Joseph Schor Foundation. It was about the search for Atlantis.

There are a lot of published reports as to what the real purpose of the expedition

was, but we were trying to find access to a room, which we believe we have identified, under the front paw of the Sphinx. That room was identified by the exploration of geophysicist/seismologist Dr Thomas Dobecki in 1991, and it was later confirmed by ground-penetrating radar in 1996.

The Egyptians have been very resistant to our suggestions that we (1) drill a hole down into the room, and (2) excavate a tunnel at the back of the Sphinx, which we

"We have also discovered a tunnel at the bottom of a well, about 120 feet down, and it is about halfway up to the Great Pyramid. We are trying to find a way to get permission to open that tunnel..."

think leads to that room. For whatever reasons, they have denied us permission to do the excavations. The bottom line is that it is their country and it is their monument. It is hard to be miffed about that. If a group of Nigerians set up shop on your front lawn and said, "We have absolute proof that Atlantis is here, under your grandfather's

grave, and we are going to dig it up," there would be trouble.

We have also discovered a tunnel at the bottom of a well, about 120 feet down, and it is about halfway up to the Great Pyramid. We are trying to find a way to get permission to open that tunnel, because we think it might lead to the Sphinx as well. That would bear out the Rosicrucian theory that the three pyramids are connected to a temple-like structure which is then connected to the Sphinx. All of this has been documented in legends, stories and the Rosicrucian records.

The problem has been getting the Egyptian Government to allow us to continue our exploration. They have a rule that says if you want to do exploration in Egypt you have to have an academic background, and an institution of higher learning has to apply for the permit.

That usually also means considerable financing, and the financing usually comes from someone like Dr Joseph Schor, someone who has an enormous personal interest in the project. I worked with him for two years. We came to a parting of the ways when he wanted to sell the show [*Secret Chamber*] to the Fox network, and Fox wanted absolute control of the subject matter. I objected to that because I thought the subject matter should speak for itself.

So I am now on my own. I have another sponsor, who has asked that his name not be revealed for the time being.

I have just returned from Egypt, where I was in the wake of the Luxor disaster. The Egyptian Government is now obviously desperate for good publicity, and I feel the climate might now be more conducive to my doing a television film.

What I have offered, relative to the room under the paw of the Sphinx, is for them to drill the holes and run cameras down into them—similar to the way they discovered the solar boats—and that we supply the engineering background and the funds. In return for this, we would have the exclusive right to televise.

The Egyptians' concern is: what if the Sphinx is damaged in the process? That is certainly a legitimate concern, and we are trying to get some engineering opinions so that we can guarantee them that it will not be damaged in the process. I have every hope that they are finally going to let us in there this Spring.

Myths & Facts



LE: So you recently came back from Egypt, and you met with the appropriate people?

BS: Yes. I met with several Egyptians who are representing me and helping me to put a project together which would be an Egyptian search for Egyptian history. If it turns out to be Atlantis, then that's great. I am a film-maker. I try to divorce myself from the thousand-and-one agendas that seem to find their way over to the plateau.

The other side of it is that in the eight years I spent there, I have discovered something on my own by bringing a couple of ex-NASA scientists over there. We found that there is a pattern of sonic resonance inside the King's Chamber of the Great Pyramid.

We suspect that this sonic resonance is enhanced by the entire structure and by the materials used in the structure. If that is true, then that would be evidence that there was a scientific logic employed in the building of the Pyramid which predates our knowledge of this sort by seven or eight thousand years. In other words, if the Pyramid was built as a giant resonance box, and if the choice of materials and the dimensions were carefully studied and the effects had a purpose, that would offer a lot more proof of the existence of an advanced civilisation. That would be better proof than some tablet that says "Made in Atlantis by the Atlanteans".

My feeling is that while we are seeking to get into the Hall of Records room under the Sphinx's paw, which is what the American television networks will buy and which will create the kind of funding that we need, I can sneak into the show some appropriate scientific facts about this sonic resonance which is as indicative of the existence of a highly advanced culture as tablets in the Hall of Records would be.

My talk at the Global Sciences Congress will be an effort to point out that evidence of this culture might not have been hidden or buried; maybe it is there and we just haven't recognised it. It is only recently that we have acquired the sensitive equipment that we need to record some of the sounds, because some of them are below the range of human hearing.

LE: Tell us about the tunnelling in the Great Pyramid that is the basis of a recent article in the publication *Atlantis Rising*. You are reported to have filmed the tunnel area.

BS: Above the King's Chamber there are five chambers. Four of the chambers are a little bit bigger than the King's Chamber; they are longer and wider. They are about 3½ feet high, so you can't stand up in them. The fifth chamber has a peaked ceiling. The chambers are all covered with graffiti, and the graffiti dates back to 1815. The top chamber was discovered in 1837. They are quite difficult to get to, and you have to know a little about rock-climbing to get to them.

A few years ago [1993], Rudolf Gantenbrink passed a robotic camera up one of the air shafts; I believe it was the one in the Queen's Chamber. At the end of this chamber, the camera came to what was described as "a door with bronze hinges".

There is a theory by Richard Hoagland and others that there is a room on the other side of this little door. What Hoagland is claiming is that the Egyptians have been tunnelling to reach that room.

When we were going up to investigate those chambers, there was in fact a new tunnel which was being excavated which is parallel to the long dimension of the first of the four chambers above the King's Chamber. The dirt and stone from this tunnel were being stored one floor above. Richard saw something sinister in that; I didn't. I think that by storing the rocks one chamber up, they didn't have to dispose of it.

If they had lowered the rock, they would have had to take it all the way down the

steps and all the way out of the Pyramid or else it would have interfered with the tourist flow.

They are now obviously doing more work, because there is now a 220-voltage power cord going up there and it's warm to the touch, which means it is being used for something. Are they honour-bound to tell us? No, I don't think so. It's their country.

Frankly, I think they are going to embark on a policy of bombarding the news with new discoveries because, otherwise, who would go to Egypt now? That slaughter at Luxor was colossal. It was ugly and it was scary. There are no tourists in Egypt now. There were 10 guests at Mena House and 11 at the Nile Hilton when I was there. So I think we are going to see a lot of information coming out now.

LE: Your position is that they can be tunnelling in secret, and they don't have to report it. They don't owe anyone an explanation. Is it common knowledge in the countryside that they are doing this, digging and exploring?

BS: You can make a whole big case out of it. They are tunnelling all over the plateau. They are doing it to the extent that they have the money to do it. It's common knowledge. Zahi Hawass has never said to me, in the eight years I've known him: "You can't go in there and film that, Boris." On two separate occasions I was given permission to drag a six-man crew up there. I haven't been the victim of any plots.

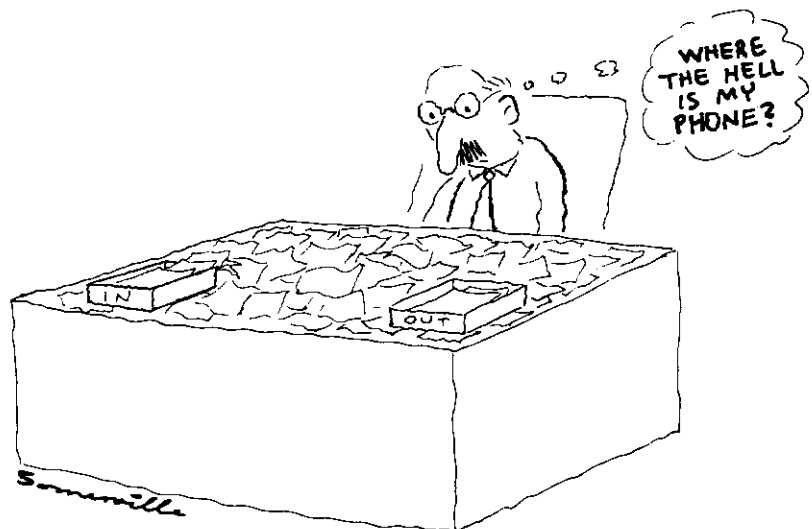

BERMUDA RECTANGLE

THE TWILIGHT ZONE

LE: If they can uncover additional treasures, that will attract even more tourists. If they can uncover a Hall of Records and can figure out a way to safely open these things to the public, wouldn't they do that?

BS: I think so, and I think they are coming to it. There was a lot of question about who does the opening, who gets the credit, who gives the permission. There is a tremendous pecking order over there. That's been what has stood in our way all along.

The other thing we must understand is that they have a US\$3 billion tourist industry, and that is, I think, their primary source of dollars. Right now they are in grave danger of losing the whole thing, and that would be a national disaster.

LE: So where do things stand now as far as your proposals are concerned?

BS: I put together a group of very influential Egyptians who are interested in salvaging their reputation and the tourist industry, and they were very solicitous and very polite. We worked out a formula for proceeding. I offered them the financing in return for the film rights and asked them if they would nominate their own committee. I offered them an international engineering firm which is based in Cairo, and I have every hope that they are going to say yes. I am really quite optimistic about it. I would hope it happens in March of 1998. Hopefully it will repair some of the damage that has been done.

Robert Bauval has the attitude that because he is an engineer they owe him some kind of candour. Candour is not a word in the Egyptian language.

The whole idea of my lecture at the Global Sciences Congress will be about the simplicity of getting things done in Egypt if you're straightforward. I just want to tell about my adventures for eight years. I have discovered some amazing, incredible things.

The most important thing that was revealed in our 1993 film, *The Mystery of the Sphinx*, was pretty conclusive proof that the Sphinx is much older than anybody thought it was. I think they proved that it was damaged by water flowing down off the plateau, and that the downflow of water was at least 9,000 years ago. So that's pretty conclusive to me as a layperson.

Also, Dr Dobecki, with his seismograph, established pretty clearly that there is a very suspicious rectangular void under the left front paw of the Sphinx, right where Edgar Cayce said it would be. Now do I know whether it's there? No. The only way to know it is there is to dig down and find out.

One of the other things that Dobecki found was a series of tunnels and voids in front of the Valley Temple, and that has since been successfully subjected to the shovel test.

The most significant thing was what an engineer named Tom Danley discovered. Tom used to work with Intersonics

Corporation; he was the one in the *Mystery of the Sphinx* who did the levitation experiments with sound.

Tom measured the Pyramid, measured the five rooms above the King's Chamber, put some huge amplifiers and woofers in the King's Chamber, created sound, measured vibratory responses in the five rooms, and created a theory. His theory is that the dimensions of the Pyramid, the materials with which the Pyramid was made and the box inside the King's Chamber all served to enhance and amplify whatever sounds were made inside the King's Chamber.

He also believes that when the wind blew across the air shafts, especially when the Pyramids were smooth in the early days, it was like blowing across the neck of a Coke bottle: it created a harmonic vibration in the chamber that was below the range of human hearing, below 16 Hz.

Tom described a certain pattern to those resonances, and the pattern or the sequence of notes described an F-sharp chord. F-sharp, according to ancient Egyptian texts, was the harmonic of the planet and, coincidentally, it is what many Native American shamans tune their sacred flutes to. So here you have 2½ million blocks piled up in Egypt, and halfway around the world you have a guy whittling on the branch of a cherry tree—and they come up with the same F-sharp resonance. Coincidence? I think not.

My feeling is that we are on track for something there, and I hope to get a chance to do some measurements at Palenque and at other sites in Mexico. We are hoping that there will be some sort of correlation between the vibrations in these pyramids, and I think that is just phenomenally interesting.

LE: So you are willing to offer support, including financial support, to the Egyptians, and what you want is to film whatever is found.

BS: Yes, that's what I want! That's what I do!

Editor's Note:

This interview first appeared in the Jan/Feb 1998 edition of *Leading Edge Newspaper*, PO Box 510, Waynesville, NC 28786, USA, phone (704) 456 3664, fax (704) 456 7565, website, leadingedge-news.com. (Subscription cost for six bi-monthly issues: USD\$12 in USA, USD\$24 elsewhere.)

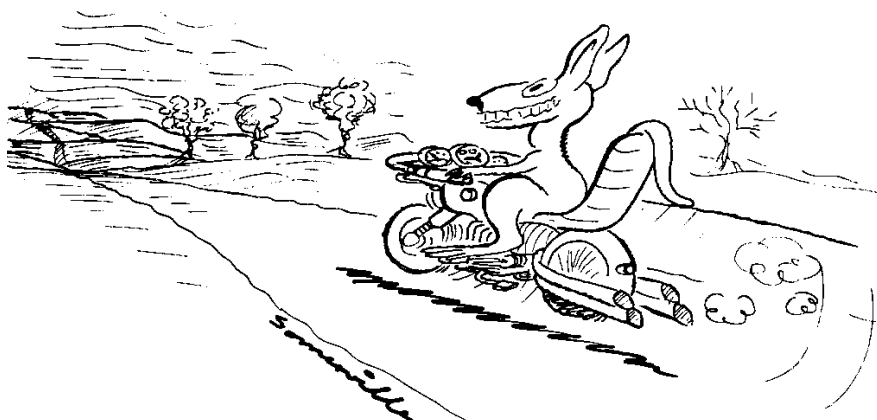

A VROOM WITH A ROO

Close Encounters with Mysterious 'Men in Black'

In 1953, American UFO research pioneer Al Bender was visited by three aliens, dressed in black, who transported him to their Antarctic base but warned him against making any of their revelations public.

Part 2

by Albert K. Bender © 1963

Extracted from his classic book
Flying Saucers and the Three Men
Published in 1963 by
Neville Spearman Limited
London, UK

We informed state and foreign representatives not to accept any further memberships because changes were in the making. They were to wait for the October [1953] issue of *Space Review* which would give more details. Our biggest job would be a clerical one, that of going through membership records and determining the amount of money to be refunded after the next issue came out. We must determine if the treasurer had enough money in the bank to make all of the refunds. We wanted to be financially square with all subscriber-members since they had remitted the money in good faith. Thus, the wheels began to turn to stop all further investigations and to close the IFSB [International Flying Saucer Bureau].

In August 1953 I was to have the pleasure of again visiting the people from another world—an experience that would be even more revealing than the last one. I had no way of knowing exactly if and when I might receive another visit, but just for experimentation I often removed the metal from the strongbox, turned on the radio and repeated the word. Nothing happened, however, so I gathered it just wasn't time for a visitation.

On a hot evening in August I was in my room busily editing copy for the October issue of *Space Review* when I thought I heard a board squeak in the attic just outside my door. I got up and went to the door to see if my stepfather might be walking about in the attic, looking for something. No light came from under the door, so I figured I had imagined the noise—until once again the odour of sulphur reached my nostrils. The odour was faint until I sat; as I did so, it became stronger. Kneeling to the floor I discovered it was even stronger there, so I supposed it had the characteristic of creeping along the floor, then rising until it reached the nostrils. Because it had always accompanied a visit from these strange beings, I could expect them shortly. I puzzled myself with the question of the odour. I had never asked about it, but would make a point to do so the first opportunity I had.

I didn't know whether I should open the door and look out into the attic or wait and see if someone was already in the room with me. As the odour grew stronger, however, I finally opened the latch. As I did so, my heart almost stopped beating! When I opened the door, there stood the same figure who had sat next to me in the theatre, followed me on the street and had paid me a visit in my room. He motioned for me to go back into the room as his eyes focused upon mine with that same luminescence. I thought he was alone, but found I was mistaken when I saw two others directly behind him. All three came into the room and closed the door.

A chill came over me as these three figures occupied the very room in which I had experienced the almost unbelievable transport of my body from one spot to another. What could they want by actually appearing in this manner and taking a chance of being seen by some other person? I backed away from them toward my bed. One came forward while the others stood in the background, looking about the room. This was my first opportunity to see them at such close range.

Their clothing was made of a black material which reminded me of cloth used in the attire of clergymen. It was well-pressed and appeared almost new. All the other apparel such as ties, shirts, stockings and shoes was also black. They wore hats, of Homburg style, also black. Their faces were unpleasant to look at. Their eyes shone like tiny flashlight bulbs and the teeth were pearly white, set in a very dark complexion. I could not see their hands; they were covered by black gloves. A bluish radiance enveloped their entire bodies, and I wondered if this was giving off the sulphuric odour.

Again I was frightened. I waited for some move on their part, for I didn't know if I was to be treated kindly or with aggression. The figure closest to me soon settled the matter as

he spoke to me in the usual manner, without moving his lips.

"We have come to take you to a most important meeting, and such is the distance that all of us must accompany you. You are to see our base of operations here on your planet. Please take your small metal disk with you."

I went to the strongbox where I kept the piece of metal, took it out and held it tightly in the palm of my hand. Then, turning to the figures, I waited further developments. They approached me and formed a circle about me, and for the first time these people from another world actually touched me. They placed their hands on my shoulders, and as they did so I felt as if I had been touched by a piece of dry ice. My whole body suddenly went numb as if I had received a giant dose of novocaine.

That was the last I remembered until I opened my eyes and found myself in a large cavern of some sort. The immense size astounded me, for I had never seen or heard of a cavern such as this one. I was not even certain I was still on Earth. After the fantastic events of the past months, I would not have been surprised had I found myself on the Moon!

My three companions were still beside me as I noticed we stood on a platform made of a bright shiny metal, reminding me of stainless steel, and a bright beam of light shone on us from an object in front of us but not far away. I wondered why so much light also came from above, and looking up discovered the reason. The entire ceiling was made of ice, and light from the surface was shining through it, illuminating the cavern. It appeared as if some superhuman being had carved this enormous cavern as a human would form a hollow spot in the snow with a hot iron. A tremendous amount of heat surely had been used to create such a hide-out.

I had a remarkable feeling that I was still on Earth, but at a remote spot where man would likely never set foot for many years. My escorts noticed my keen interest in my surroundings

and pointed to a metal path directly ahead of me, indicating I should take it. I walked on, and as I did the beam of light followed us. The path continued straight for some distance, then made a sharp turn to the right; and there, nestled in a larger portion of the cavern, loomed a huge cigar-shaped object resembling one of our rockets, though as big or bigger than one of our ocean liners. I couldn't see the other end of it from my vantage point, but noted it was constructed of similar shiny metal and contained porthole-type openings in its side.

The path led directly to a panel in the side of the enormous object. As I reached the panel, the beam of light which had accompanied us focused on a small bubble on the panel. At once it slid back, making a shrill, piercing noise. I entered, followed by the three escorts. As we did so, the panel closed behind us with the same noise. I could not hope to imagine what would happen to me, why I had been brought here and whom I was to meet.

We were in a long corridor with panels at various points along the walls. Above all the panels were small, glowing bubbles, some of the same colour, others varying in hue. My escorts halted at one panel and one of them removed a small cylindrical object, similar to a flashlight, from his clothing, and shone it on a small hole in the panel. The door slid open at once. They beckoned me to step inside, and I found myself in a room resembling a laboratory in a chemical plant.

The lab was equipped with complicated machinery, all of which seemed to be made from the same shiny metal. At many locations in the long lines of tubes and coils, globular glass containers interrupted the flow of a travelling liquid which was clear like water. It was evidently heated by some means, for it was bubbling away into vapour. My impression was that of witnessing some distilling operation of gargantuan scale. At one end of the lab stood a huge instrument complex of gauges, lights and meters. Someone sat at the panel, working levers and pushing buttons. As we approached, my three escorts stopped and the panel operator turned to them and spoke, still without lip movement. Although I had been able to understand all which had been said previously, I could not grasp their communication. I knew, however, they were conversing.

The operator retained his natural, monster-like appearance, as I had seen on the screen in the room with the glass dome. He was no taller than my escorts, but quite ugly. His outline was bulky and almost oblong. But his eyes conveyed that same glow, and when he looked at me I could feel them burning into my very soul. I then sensed he was speaking to me.

"Welcome to our base of operations here on your planet of Earth. You have travelled many miles to reach this spot, but the time has been only seconds, whereas you would require many days to reach this same area by your conventional means of transportation.

"You are at a spot on your planet known as Antarctica. We have chosen this area because it is uninhabited and there is no one here to disturb us in our task. We have made this base by tunnelling into your ice-covered surface and burying ourselves, with only a small opening through which our smaller craft may enter and depart. The intense cold here does not disturb us, for we are not affected by your range of temperature. Our bodies acclimate themselves readily to such ranges. The surface of our home planet is barren and the cold even more intense than here in your southern polar region.

"All our cities are constructed underground. We have crater-like openings on the surface, through which we are able to elevate spacecraft stations for take-offs and landings. When these stations are not in use they descend into the craters, and the landing

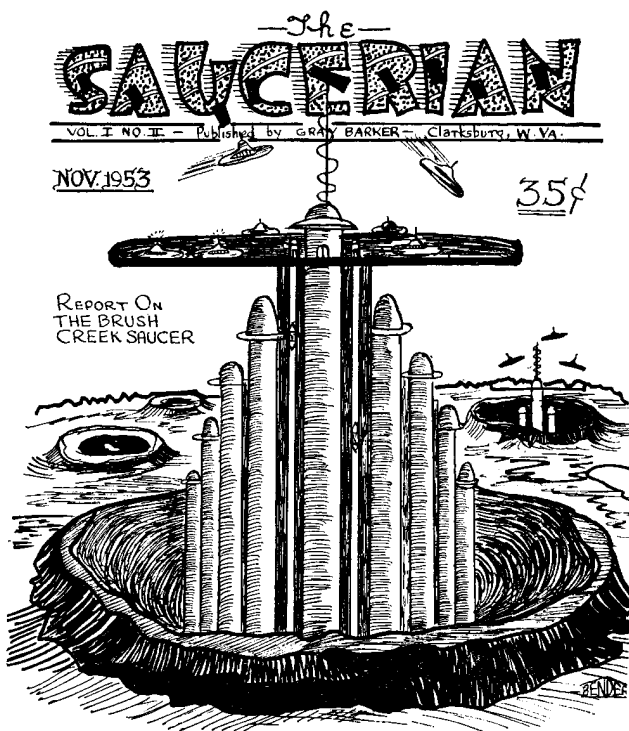

The cover of an early issue of *The Saucerian*, designed by Albert K. Bender (now deceased)

fields serve as a cover for the openings, with only communications towers visible.

"I have been instructed to show you just what we are doing with your sea water which we are taking from the surface of your planet. First we will show you how this water reaches us, so we must go to an adjoining room. Your escorts will take you on this tour and then will return you to this room, where I will explain the breakdown of the water."

With that he dismissed us. My escorts led me to another wall panel and, again using the 'flashlight', caused it to slide open. We stepped through into a long, narrow tunnel that looked like a New York subway, though on a much smaller scale. We approached a small mobile unit containing seats. It was supported by a single rail and evidently was used for transportation throughout the large enclosure which I believed to be a spacecraft. At their motion I climbed into one of the seats, and they also seated themselves. No sooner were we seated than the unit sped down the track with a humming noise. A light shone from its front and illuminated the passageway. I noted many lights along the route we were speedily traversing, and gathered these were stations along this monorail set-up.

We came to a sudden halt and stepped onto a platform facing another panel. The escort with his door-opening device again flashed it, and we entered a large circular room that was buzzing with activity. The wall was covered by instrument boards before which seated operators manipulated levers and buttons. Lights flashed here and there. Fenced off by metal railing was a large circular opening in the floor. We walked to the railing, and I estimated the opening to be about sixty feet across, if not more. Looking down I saw an elevator-like device ascending. It reached the floor level, and without halting moved toward the ceiling. As it rose, a panel in the ceiling opened. A large cylinder, evidently working from below, supported the platform, which halted when it had protruded through the ceiling.

A large screen then lighted on a nearby instrument board, and a bright dot appeared. The dot moved from one side of the screen to a point near the centre, reminding me of a radar screen. The dot then glowed red and died out. From above came a vibration, as if something had struck the roof lightly. The platform then descended, and I could hardly believe my eyes when I saw what it supported as it reached floor level.

Here was my first view of a real flying saucer, and I was only a few feet from it! What a beautiful machine to look at: completely round, with a section of portholes, and a single metal rod protruding from the top of the craft. It was constructed of the same shiny metal. I couldn't detect any door or panel from which occupants could emerge, but later would be enlightened on that point.

The saucer descended through the opening in the floor until it was out of sight. My three escorts then took me to a round pillar, about nine feet in diameter, in one section of the room. He opened a panel which closed after we stepped inside the pillar. I noted we were in an elevator, as one of the men pressed a wall button and the floor began to descend.

When we stopped, the panel again opened and we stepped out into a long tunnel of such size I could hardly believe I was still inside the large craft. The saucer which had just descended on the large elevator was now just in front of us. A long tube had emerged from under the craft and was discharging what appeared to be water into a funnel-like device that sucked the liquid inward with great rapidity. As the eyes of one of my escorts glowed into mine, he conveyed the message that this was sea water from the surface of the Earth.

After the saucer had discharged its load, it moved along a track to a siding similar to a railroad yard, for many such tracks traversed this tunnel, and I had rubbed my eyes when I caught sight of so many saucers, all sitting on sidings with platforms for the occupants to use when entering and departing. In Earth terminology, I suppose this would be called an enormous saucer garage. The smell of sulphur lingered all about, and I wondered if this odour had anything to do with the fuel being employed.

**"You are at a spot
on your planet
known as
Antarctica.
We have chosen
this area because
it is uninhabited
and there is no one
here to disturb us
in our task."**

We retraced our route and again I found myself in the laboratory from which we had begun our tour. The 'monster' I had previously met in the lab confronted us, and for the first time since they brought me to this strange place, all three escorts departed. The 'monster' took me to the instrument panel and pointed to a small gauge containing figures of odd appearance. From beneath the gauge a pipe extended to the walls and into the system of coils and tubes.

This, I was told, was the point where the sea water entered the lab from large tanks below. It was sent through the tubes and coils where it was processed to obtain the product they needed. I learned not one single thing about how the process worked or the nature of the final product they extracted. I hoped I might see the finished product, and was delighted when I learned I would now have such an opportunity.

He took me to an adjoining room where a huge machine occupied its centre. It contained many meters, gauges, buttons, dials and the like. The

machine emitted a strange noise as three operators, similar in appearance to my guide, adjusted knobs and operated switches. From the far end of this machine, a small conveyer in a glass tube carried tiny blocks of compressed material, which reminded me of bouillon cubes, through the wall. I was allowed little time in this room, and no offer was made to show me anything further about the processing. I assume that great secrecy surrounded the final disposition of the processed material, and sensed this was a forbidden area of discussion.

Once again I was taken back to the lab, where my three original escorts waited for me. From their actions I gathered my tour was not over. Again we took a ride on the monorail system, this time stopping at a different station but again stepping into an elevator. We emerged into a brilliantly lighted, semicircular room containing a row of chairs. The floor intrigued me for it reminded me of tile, but each block was made of the shiny metal, with a hammered design—a masterpiece of workmanship like nothing I had ever seen.

A large panel faced the row of chairs, and over it a large bubble glowed a deep red as we seated ourselves directly before it. One escort arose, went to a panel of buttons at one side of the panel and pressed one of them. With a hum, the panel slid open. He motioned to us and we arose and followed him through the door, down a long hallway to yet another panel. We stopped for a few seconds, whereupon a red light glowed above the panel, and the same escort again pressed a button and the panel opened.

I found myself in another semicircular room, though larger than the first. The walls were covered with glass screens of milky-white appearance similar to television picture tubes. The screens were divided by metal frameworks. In the centre of the room stood a circular dais on which I noted a slanted instrument panel, containing many buttons and knobs, mounted on a metal pedestal. In front of the panel was a seat for an operator not yet present. We walked to the centre of the room, stepped up onto the dais, and sat in a half-circle of seats before the panel.

Immediately the room began to grow dark, and from a sliding panel facing us on the opposite wall stepped a figure glimmering in a blue haze. He was dressed in a uniform of golden colour. His silvery white hair contrasted with the skin of light brown colour. He appeared as if he might have a very heavy suntan. As he drew closer, my attention focused on his face of handsome features. It was almost Earthlike, contrasted to the ugliness I had observed in the others. He was of muscular build and about nine feet tall. I gathered this was the "exalted one" about which I had been informed, and that this bisexual entity was in charge of the base and probably the entire planetary operation.

The three men rose as he approached, and I did likewise. They bowed as he stepped upon the dais. Each of my escorts then took a piece of metal, like mine, which I then discovered they were holding tightly in their hands, and in turn walked to the exalted one and pressed it to his forehead. I presumed I should do the same, and followed suit. When I touched his forehead with the metal I felt a tingling shock go through my arm and into the temples of my head. The exalted one sat at the operator's position in front of the instrument panel and we also seated ourselves.

He turned and looked directly into my eyes, and I noticed that his eyes also glowed. Like those of the others, his eyes seemed to penetrate deep within me. Then he spoke to me without lip movement.

"I bid you a cordial welcome to our base of operations on your planet, and it is with deepest esteem that I permit you to be our honoured guest because you have given so much of your time to establishing friendly relationships with visitors from space. We knew of your activities long before you tried vainly to contact us with your experiment. Prior to our personal contact with you, we had you watched. We were merely testing your sincerity.

"Having proven to us that you were a trustworthy person who had much willpower, you, above anyone else, were chosen to visit with us and learn of our purpose here on your planet. You have already learned many things about us. You have listened courteously without troubling us with many questions, but I am certain you have many you would like to ask us, so we are now prepared to permit you to ask any questions you desire; but we must be free to decline to answer any we feel is out of order. May we now hear your questions?"

Here indeed was the moment I had awaited; an invitation to satisfy my curiosity upon so many points and to hear the answers direct from the 'head man' of the saucer people on Earth. Giving the matter quick but considerable thought, I decided I must ask questions of importance for I didn't know how much time would be allotted for the interrogation.

My first question came out without great hesitation.

"How long have you been on our planet?"

He answered unhesitatingly, "Since the year 1945 in your length of time."

I continued. "What is your main purpose in coming to our planet?"

"To obtain water from your vast bodies of sea."

"For what purpose are you using this sea water?"

"We cannot answer that, but we have shown you what we do with it once we obtain it."

"Do you intend to stay on our planet long?"

"Perhaps a period of fifteen of your planet years."

"Do you make trips back and forth to your planet while you are here on Earth?"

He did not answer "Yes", but replied, "We have been changing our crews every two years."

"I was told that you return some of the waste material from the sea water to the sea from which it came, but watching your process I did not see how this was done."

"The waste is returned in the small craft that bring in the fresh supply. It is actually strewn while the craft is in flight."

"Do you intend to cause any harm to our people while you are here?"

"We have found it necessary to frighten many, but we also have had to resort to graver action in some cases

which involved deaths among your fellow Earthmen. We have carried off many of your people to our own planet for means of experimentation and also to place some of them on exhibit for our own people to see. We have specimens of peoples from many planets, but some of them do not live. These we preserve. Such has been the case of your Earth people; they have not survived."

"Do you intend to take me to your planet at any time?"

"We would not take you to our planet unless you became an obstacle in our path; then we might find such action necessary."

"Have I been an obstacle to you so far?"

"You have not done anything to harm us, but you have delved deep into the minds of our people by your determined initiative."

"Why have you chosen me above some of our most brilliant men on our Earth?"

"Any person of high intellect or position in your society would not be satisfied with what we had shown or explained to him at this point. He would be inclined to keep the secret only until he was out of sight and then would have everyone out searching for us."

"May I ask you some questions that have been puzzling me for many years, to which there is, of course, no true answer here on Earth as yet? Our scientists only surmise and guess as to these things and do not know for sure."

"You may ask any questions you like, but, I repeat, I will not answer if I feel I should not do so. Let us have some of these questions."

"The big question I wish to ask first of all: How far does space

Here indeed was the moment I had awaited; an invitation to satisfy my curiosity upon so many points and to hear the answers direct from the 'head man' of the saucer people on Earth.

extend? This is our biggest mystery."

"You have chosen a very important question, and I feel you are clever for doing so. Space or the great void has no end as far as we have been able to explore. As we explained previously, there is a large main body from which all the planets and their suns are formed by means of being cast off into this vast void we call space. This main body seems to grow in size and never diminishes, despite the fact that it discards new bodies constantly. It is so hot a mass you could not go near it, even in terms of billions of your light years. All the bodies cast off are hot, burning balls of fire, and as they reach the cooler parts of space they explode and form smaller bodies that circle them. These smaller bodies become planets as they cool off, but the cooling-off period consumes many, many years. We have sent out spacecraft to explore the regions beyond the circling bodies where there is an area that is deep black and in which you are unable to see anything. This vast black area is waiting for bodies to fill it. We have lost many of our exploring craft that went too far into the deep black and never returned. I think it would be clearer if we showed a picture to you on one of our screens. If you will look upon this frame of light you will receive a better idea of what we have tried to explain."

The dais revolved until we faced a lighted screen. On it appeared a three-dimensional sky map, showing the large central body glowing a fiery red, twirling about and sending off balls of fire which seemed to take paths around it. Many small solar systems revolved around the central body—so many that it was impossible to determine some of them from others. Each body was a small speck of dust, and I suspected that many of them were thousands of times larger than Earth.

Circling the edge of the screen was a deep, inky black from which not a speck of light shone. This was the outer void which had no end, the region from which their people had not returned. This magnificent view vanished and I resumed my questions.

"Since you have explored so much of space and the bodies that are now about us, I would like to know if there is life on any of our other planets in our own solar system."

"It was mentioned to you previously that at one time people existed on the planet you call the Red Planet, or Mars. They were destroyed by people from a passing planet similar to ours. They were exploited and ravaged by these visitors. The other planet nearest you, called Venus, is covered in shroud because it is going through a prehistoric stage similar to the one your planet experienced so many years ago. Life is just developing there. Whether it will be like that of your Earth we do not know, but it has similar characteristics to life in your early evolution."

"Are there any signs on Mars that life did exist there?"

"Yes, there are ruined cities which were masterpieces of architecture, and the remains of a vast system of waterways that were used mainly for travel. When destroyed, the people there did not employ air travel; neither had they developed a technology to equal your present state of progress."

"Many of these things you have told me are similar to what some of our astronomers and scientists have surmised. Are they correct in most of their assumptions?"

"You have many wise men and women on your planet, and they could go to great lengths with their intelligence if they would

make use of it in a peaceful way, without trying to destroy each other with horrible weapons."

"Are there any other inhabited planets in our system?"

"You are the sole planet with human life in your solar system."

"Could a person from Earth survive on any of the other planets in our solar system?"

"No, not without special equipment."

"Do you think we will ever reach our Moon or Mars or Venus?"

"Yes, you will reach your Moon, but it holds great disappointments for members of your races."

"Is the Moon rich in minerals that we might use here on Earth?"

"Yes, it is very rich, and I might add that, unknown to many of your people, there is moisture in many of the craters of the Moon."

"What caused these craters?"

"Most of them were caused by a cooling-down process when the Moon was thrown from the Earth itself; but some of them were caused by large meteors which hit the face of the Moon when another solar system was thrown from the central body at about the same time your system was born."

"Do you believe in God?"

"That is a creation of your people on Earth. You have strange races and colours in your people, and many languages are spoken, but it seems that all your peoples have had the desire to worship something during their evolution. They, growing like small children, wanted to have an anthropomorphised idea to cling to. Their belief was so great that in some cases miracles seem to have been created. These were written down for others to read, but these stories were told over and over until they are now considered to

be true."

"What about Jesus Christ here on Earth?"

"A great believer in the God, with miraculous attributes of great exaggeration. He could not save himself from death, and even his own race did not believe in him, yet they worshipped the same God."

"Do you not have a god on your own planet, and do you worship anything?"

"We do not worship anything, but we all know that the great central body created all of us and cast us off into space to form a life or to remain a barren piece of matter floating about."

"What about Jesus Christ ascending into heaven, since they could not find his body?"

"We have studied all these things of your planet and have often thought how primitive your people appear to be. They are easily convinced of anything. They can be led by anyone who can turn their loves or hatreds in directions so desired by leaders. Yours are a vulnerable people: as long as somebody leads them, they feel safe. On our planet, every person is independent and his own leader. Some may be superior in intellect, but they are merely respected and do not become leaders. In the case of your religious leader, Jesus Christ, the wisest man of all was not the religious leader himself, but the person who devised the idea to hide away or destroy his body so that for centuries afterward people would benefit from the celebration of the birth and death of this prophet. It is best to leave many things unsaid in the area of your religions, for it is a topic which causes great upheaval on your planet."

"Yours are a vulnerable people: as long as somebody leads them, they feel safe. On our planet, every person is independent and his own leader. Some may be superior in intellect, but they are merely respected and do not become leaders."

"Is there a life after death?"

"On our planet there is no life once the body is destroyed, but we are fortunate in having a life-span five times your own. Some live even longer, but they are the gifted ones. We have no disease on our planet, but the thing which causes many to die is the great blackness that covers our planet when we pass a certain cluster of celestial bodies on our trip around the great central body. This has been our reason for living underground and sealing all surface openings against penetration of a strong gas which troubles us at such times."

"How do you account for the apparitions and ghosts that people claim to see?"

"It will surprise you to learn that beneath the surface of your planet, far down in cavernous cities, live creatures that are able to make themselves invisible when they come to the surface. They roam the surface of your planet quite frequently and like to cause fright to cover their stealing of certain things which they take back with them."

"What would you say is the cause of the dreaded disease of cancer we have on Earth?"

"The advent of your gasoline-propelled vehicles is a main factor."

"Will there ever be a cure?"

"Yes, your learned men will develop a cure."

"Could you show me some scenes of life on your planet?"

"I had hoped you would express curiosity about this, but I first wanted you to feel free to ask about your own."

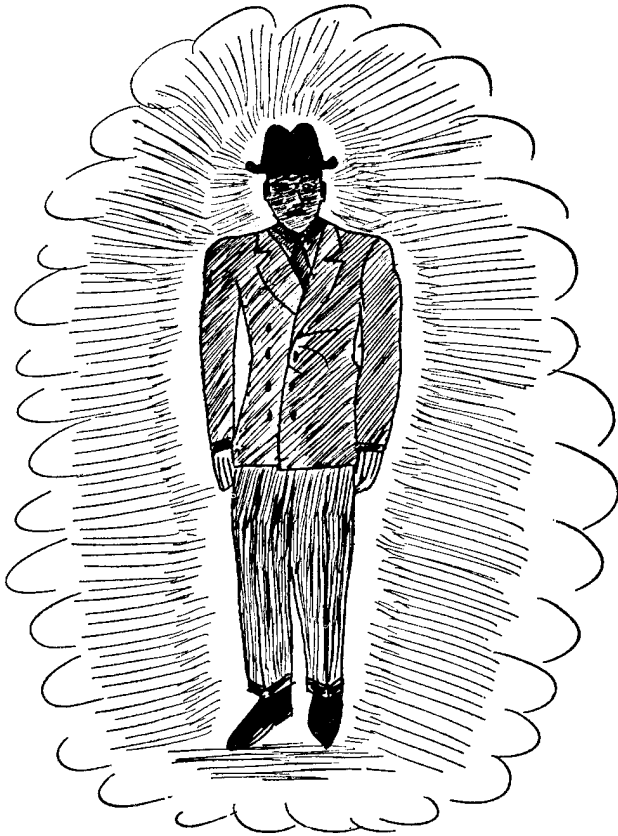

The author's rough sketch of one of the three men. The eyes glowed like two flashlight bulbs.

At this point the lights dimmed and the dais revolved, as screens about the walls lighted with scenes of life on the planet of these strange visitors. The exalted one pressed buttons and pulled levers on the instrument panel as he explained the scenes, or "frames" as he termed them.

"In the first frame you will see a view of the surface of our planet, in one particular area. If you watch closely, you will see how the elevated landing fields come up from below with the massive towers and elevator shafts. Many of our cities are not connected by underground passageways, and therefore major travel is carried out on the surface by the small craft."

As he explained each frame, he kept his eyes focused upon me. My head continued to throb and my eyes burned, though I was so fascinated by the experience I almost forgot the discomfort. Soon a second frame appeared. This showed an underground city. It was magnificent, lighted like daylight by some unknown source. Buildings were connect-

ed by transparent tubular roadways, supported only by the buildings they connected. Small vehicles moved in both directions in the centre portions of these tubes and people walked on both sides.

The next frame depicted a building resembling a vault or tomb. An inside view showed walls containing drawers or trays. In opened trays appeared objects which looked like ostrich eggs. These, I was told, were the future generations of the planet, hatched by controlled system whenever the blackness approached and caused many deaths. I learned, too, they were also hatched to replace any persons dying of accident.

Another frame exhibited a large underground firing range where several people practised the use of a peculiar firearm. It was a silver, tubelike device with several buttons on the handle. As the men pressed the buttons, large fireballs shot out the end and burned through huge sheets of metal placed some distance away. I was told this was one of their weapons. But of the firing, this impressed me most: after the fireball pierced the thick metal, it would make a loop and slowly return through the air until it once again entered the 'gun' from which it had been fired! The ball returned in a kind of slow motion. This evidently recharged the tubes, for, once the ball had returned, it was fired again.

I asked further questions.

"Is this your most powerful weapon?"

"No, it is not. We have a weapon that is even too horrible to show to you."

"Could you tell me a little of its nature?"

"It is a ray with a long range which burns up everything in its path."

"Have you ever used this weapon in a warlike manner?"

"Only to ward off invaders that try to do us harm."

"What is the food on your planet? Do you have plants and animals?"

"We live mainly on a fungus kind of growth similar to your mushrooms. We grow many varieties, of different food values. We also consume many types of shell-covered water creatures. Large plants which grow near our bodies of water bear delicious fruit. From this we make many of our food products."

"If you have water on your planet, why is it necessary for you to take water from our seas?"

"It will surprise you to learn that beneath the surface of your planet, far down in cavernous cities, live creatures that are able to make themselves invisible when they come to the surface."

"The water of our planet contains no impurities. We have no water similar to your sea water which is so rich in many things."

"Would it be possible for me to write about my experiences so that others on Earth can learn of your existence?"

"We do not want you to tell anything to anybody about what has happened to you. You must keep all of this a complete secret. To date you have done well, though your reasons for secrecy have been motivated by factors other than fear of consequences from us. As long as you possess the small piece of metal, you will be under our power."

"Why does my head hurt so severely when I am in the presence of you or those who have visited me at home?"

"We are able to penetrate your skull and gain complete control of your body."

"Is there any possible way by which you can convince me that this is not just a dream? Can you, let us say, perform some kind of manoeuvre or make an appearance near my home which not only will make me realise that you actually exist, but will also demonstrate your reality to others who are sceptical about the existence of the flying saucers?"

"We can create an event that will prove this to you, but we do not wish you to tell others of its actual genesis. In a few days we will send one of our small craft into your area, where it will eject a fireball which will penetrate something of little value. We will not harm anyone, although it could cause a great deal of excitement in your community."

"Will this occur near my home?"

"It will be near enough for you to hear about it and see the results."

Suddenly the exalted one rose, and I knew that the interview had ended. He bade me farewell, and then each of the three escorts approached him and pressed their metal discs to his fore-

head. They said I should do likewise. The exalted one then left the room in the same manner as he had entered.

The three men guided me back to the monorail car and we retraced our route back to the small metal ramp where we had first entered the spaceship. Although I am certain the temperature must have been extremely low, I did not feel any change of temperature. I did find myself clutching the piece of metal more tightly, and as I released the pressure lightly I immediately felt cold. The metal may have been a factor in keeping me immune to the low temperature—I never did think to ask questions about this.

As I descended a flight of metal steps onto the floor of the cavern, my three escorts suddenly halted me and again formed a circle around me. They held the pieces of metal to my head and I again lost consciousness.

When I regained my senses I was standing alone in the centre of my den. The headache remained and my eyes burned and felt swollen. I sat down on the bed and rubbed my eyes and head. Again I wondered if I were going out of my mind. Had I suffered some kind of fit? Had I dreamed this and the other realistic experiences? I began to think it might be logical and wise to see a doctor.

Suddenly I realised I no longer held the piece of metal, and my fears grew. Acting on impulse, I ran to the strongbox and opened it. There, at the bottom of the box, shining as before, lay the metal disc! I picked it up, and as I did so the pain over my eyes grew intense. As I replaced it in the box, the pain went away. I locked the box again and went to my bed to lie down. As I did so I looked at the clock and noted it was 4.00 am. I had been gone about six hours! Only a few hours remained before I must go to work, so I lay down and fell almost instantly asleep.



REVIEWS

BOOKS

Reviewed by Ruth Parnell

CANNIBALS, COWS & THE CJD CATASTROPHE

by Jennifer Cooke

Publisher: Random House, Aust, 1998

ISBN: 0-09-183691-3 (398pp h/c)

Price: AUD\$24.95; NZD\$27.95

Distributor: Aust/NZ—Random House.

In late November 1991 in Australia's Federal Parliament came the first public announcement of deaths from Creutzfeldt-Jakob disease (CJD) attributable to human pituitary hormone (hPG) injections used in women's fertility and children's growth programs. Public outrage followed when it was realised that the warning signs were there in the mid-1980s; that unethical and unsafe practices were the norm in the extraction of pituitary glands from cadavers; that blood bank supplies were probably already contaminated with CJD; and that the debilitating disease could take hold well over a decade after cessation of the hormone injections.

One journalist to reveal the cover-up and the human cost was Jennifer Cooke, a senior medical writer with the *Sydney Morning Herald*, who went on to spend much of the next five years researching the CJD crisis in Australia and around the world. She had planned to focus her book on the CJD/hPG tragedy, but when the deaths of 10 young Britons from a new variant strain of CJD were linked with the BSE (mad cow disease) epidemic in March 1996, Cooke was compelled to expand the scope to cover the links between various spongiform "prion" diseases: CJD, kuru (found in some Papua New Guinean highland tribes who practised

cannibalism), BSE and scrapie.

Her chilling, detective-style account, *Cannibals, Cows & the CJD Catastrophe*, includes interviews with key scientists, the heart-wrenching experiences of many victims and their families, and the ongoing litigation in Australia, UK and Europe. Her warnings about a time bomb waiting to go off have serious implications for us all.

HITLER AND HIS SECRET PARTNERS: Contributions, Loot and Rewards

by James Pool

Publisher: Pocket Books, USA, 1997

ISBN: 0-671-76081-5 (425pp h/c),

Price: AUD\$34.95; NZD\$39.95;

STG£18.99; NFL\$52.90; USD\$24.00;

CAN\$32.00

Distributors: Aust/UK/USA/Canada—Simon & Schuster; NZ—Macmillan, ph (09) 415 6677; Europe—NEXUS Office.

Since the fall of the Iron Curtain, much new information has emerged about the rise and fall of Hitler, the Nazis and the Third Reich. This book, *Hitler and His Secret Partners*, is another interesting exposé of what went on behind the scenes of the regime. Author James Pool argues that it was greed as much as lust for power that was at the heart of the Third Reich (though, surely, greed and lust for power are fundamental to any regime!).

Hitler's partners were the secret government of his day: the industrialists, bankers and military, all working together to fund the expansionist dream which World War I failed to materialise. While the occult motivations behind Hitler and the Third Reich are not part of Pool's domain, there are revelations enough about how Hitler's supporters

were rewarded for their funding of the regime in the lead-up to and throughout World War II. Central to his argument is that the Jewish Holocaust was largely motivated by profit and the opportunity to seize Jewish property.

Hitler and His Secret Partners covers the 1933 to 1945 period, but, to get a firmer grasp on the big picture according to Pool, the reader should refer to his earlier work, *Who Financed Hitler*, which considers the lead-up period of 1919 to 1933 and goes into more detail on Hitler's foreign financiers. In this volume, the foreign influences emerge more as (questionable) moral supporters than financial saviours.

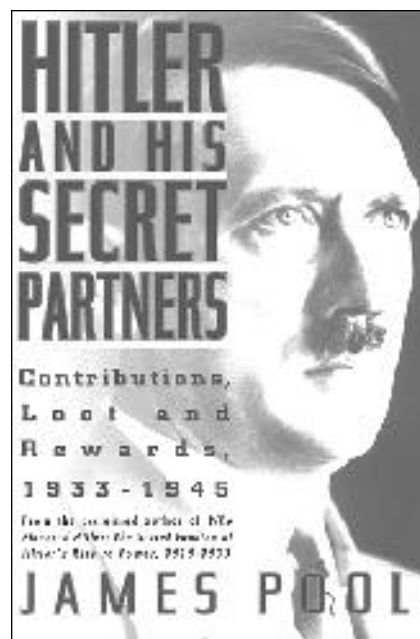

REVIEWS



BOOKS

FOOD PETS DIE FOR

by Ann N. Martin

Publisher: NewSage Press, USA, 1997

ISBN: 0-939165-31-7 (144pp s/c)

Price: AUD\$26.00; STG£11.00;

NFLf28,90; USD\$12.95

Distributors: **Aust**—Cameron Books, ph (02) 4758 7676; **UK/Eur**—NEXUS offices;

USA—NewSage Press, PO Box 607, Troutdale, OR 97060-0607, ph (503) 695 2211; Publishers Group West, ph 1800 788 3123, fax (510) 568 1834.

Most commercially produced pet food is garbage, according to concerned pet-owner Ann Martin. In the seven years since her two dogs became ill after eating contaminated dry dog-food, Martin has devoted her life to investigating and publicising exactly what goes into those cans and bags of pet food, but she has had to endure running battles with the largely unregulated, multibillion-dollar pet-food industry. Her book, *Food Pets Die For*, exposes the shocking reality of pet-food production in North America, although the situation is similar throughout the world.

As Martin progressed on her research trail, she became increasingly disgusted at the lack of regulations to prevent companion animals being rendered and ending up in pet food. She was horrified to learn that commercial pet food is full of hazardous substances: drugs, hormones, heavy metals, pesticides, plastics, pathogens, rancid fat, and even the euthanising agent pentobarbital whose presence in food is undetectable. (See her article in NEXUS 4/01.)

Martin warns that it is only a matter of

time before the BSE crisis hits the North American farming sector, then the pet-food industry and, ultimately, human consumers of farm animals fed with infected stockfeed.

Martin encourages pet owners to be more aware of what they feed their pets, but if they *must* buy commercial pet foods they should at least be able to translate the labels. Her findings here are an eye-opener, but she goes further by offering alternative dietary advice as well as pages of nutritious recipes and helpful hints for healthy pets.

LOST SCIENCE

by Gerry Vassilatos

Publisher: Borderland Sciences Research Foundation, USA, 1997

ISBN: 0-945685-25-4 (347pp s/c)

Price: AUD\$29.00; NZD\$39.00;

STG£14.50; NFLf37,90; USD\$16.95 +p/h

Available: **Aust/NZ/UK/Eur**—NEXUS offices; **USA**—Adventures Unlimited, ph (815) 253 6390, fax (815) 253 6300.

Frontier science researcher Gerry Vassilatos has been contributing for years to the Borderland Sciences Research Foundation (BSRF) and its journal, uncovering the forgotten and/or suppressed scientists/inventors whose ideas and inventions represent a sci-tech paradigm shift that may yet become a reality. Now, a selection of in-depth biographies of such luminaries has been compiled for *Lost Science*, the first volume in a new BSRF series.

Vassilatos starts off in the early 19th century with Baron Karl von Reichenbach who discovered luminous "od" energy and pioneered aura research. He then considers the mid- and late-19th century breakthroughs of Antonio Meucci in physiophony (hearing through the body) and telephony, and of

Nathan Stubblefield with his devices powered by Earth energy from the ground.

Next, and moving into the 20th century, is Dr Nikola Tesla's research into broadcast power; Dr Royal R. Rife's Universal Microscope and cancer-killing beam ray unit (and AMA/FDA suppression tactics); T. Henry Moray's cosmic ray receiver; Thomas T. Brown's gravitational warp research; Dr Vladimir Gavreau's discovery of deadly infrasound; and, up into the 1950s, Philo T. Farnsworth's controlled fusion devices.

Vassilatos expands each chapter with historical and anecdotal detail to help the reader better appreciate the context of the inventors and inventions. A final treat is his inspiring last chapter on mind, fire and thermodynamics, written in praise of Nature.





REVIEWS

BOOKS

EATING WITH CONSCIENCE

by Dr Michael W. Fox

Publisher: NewSage Press, USA, 1997

ISBN: 0-939165-30-9 (192pp s/c)

Price: AUD\$30.00; STG£13.50;

NFLf32.90; USD\$14.95

Distributors: **Aust**—Cameron Books, ph

(02) 4758 7676; **UK/Eur**—NEXUS offices;

USA—NewSage Press, ph (503) 695 2211,

fax (503) 695 5406; Publishers Group

West, fax (510) 658 1834.

By unthinkingly consuming the food products of agribusiness we place not only our health and the environment in jeopardy, but we defile the sacred bonds that link the human, animal, plant and mineral kingdoms. But by making better-informed consumption decisions we could yet reverse this trend towards "agricide".

So urges author/columnist Dr Michael Fox, a UK-trained veterinarian who has been an animal welfare activist and bioethicist for the Humane Society of the US since 1976. In his new book, *Eating with Conscience*, he considers the ethical and environmental implications of intensive factory farming and aquaculture; the rotten roots of agribusiness and the trend towards corporate serfdom on the land; the dangers of eating genetically engineered or contaminated food; and the changes we can make for a greener, safer, more humane world.

Dr Fox particularly cautions the US to take effective preventive measures to avert a mad cow disease epidemic that would have devastating consequences for beast and man alike. With 130,000 cattle, 7,000 calves, 360,000 pigs and 24 million chickens killed

in the US every day to support meat-based diets, and with the meat authorities' difficulty in policing contaminated offal being fed to these animals, it may not be too long before the first BSE/CJD outbreak emerges in the United States.

Eating with Conscience is an impassioned plea, backed up with lots of quotable facts and figures plus resource info. It may even turn die-hard meat-eaters into vegetarians.

THE WATER WIZARD

by Viktor Schaubberger (translated and edited by Callum Coats)

Publisher: Gateway Books, UK, 1998

ISBN: 1-85860-049-9 (224pp s/c)

Price: AUD\$39.00; NZD\$48.95;

STG£13.50; NFLf43.90; USD\$17.95

Distributors: **Aust**—Banyan Tree Books,

ph (08) 8363 4244; **Aust/NZ/UK/Eur**—

NEXUS offices; **USA**—Access Publishers

Network, ph 1800 345 0096.

Austrian theorist and engineering genius Viktor Schaubberger (1885–1958) spent a lifetime observing and intuiting the processes of Nature, water in particular. So much so, he earned the nickname "the Water Wizard"—an apt title for this book.

This is the first of four volumes in the milestone Eco-Technology series, encapsulating for the first time in English the letters, papers, articles and debates of Viktor Schaubberger. (Forthcoming volumes will cover trees, soil and fertility.) The material has been painstakingly collated, translated and edited by Callum Coats who has spent many years studying Schaubberger's theories and inventions and has had access to family archives courtesy of Viktor's son Walter. Coats is also the author of *Living Energies*, the definitive account of Schaubberger's life

and achievements, published in 1996 (see articles in NEXUS 3/03 to 3/05).

Viktor Schaubberger well understood the importance of water as a life-giver, but he equally understood how water can become diseased and devoid of life-enhancing energy when treated incorrectly or ignorantly. What he criticised vehemently in his day about poor water-management practices is applicable even more so today.

Water quality control workers, for instance, need to be aware that recycled water is lifeless and unfit for human consumption unless it has been reinvigorated—using simple energy-restoring technologies. In fact, anyone who has anything to do with water, whether catching, storing, drinking or disposing of it, should be encouraged to study and apply Schaubberger's principles and practices.

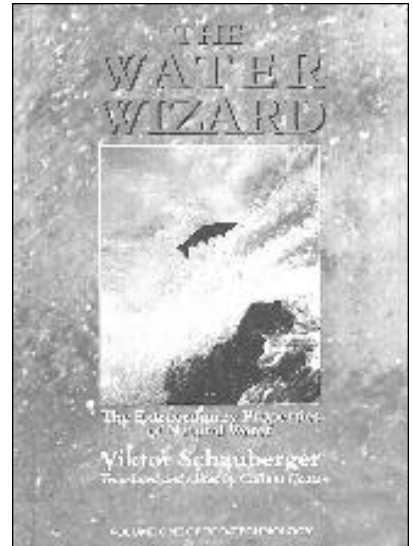

REVIEWS



BOOKS

VOYAGES INTO THE UNKNOWN

by Bruce Moen

Publisher: Hampton Roads, USA, 1997

ISBN: 1-57174-068-6 (241pp s/c)

Price: AUD\$25.95; NZD\$29.95;

STG£13.50; NFLf28.90; USD\$12.95

Distributors: **Aust**—Gemcraft Books, ph (03) 9888 0111; **NZ**—Peaceful Living, ph (07) 571 8105; **UK/Eur**—NEXUS offices; **USA**—Hampton Roads Publishing Co., 134 Burgess Lane, Charlottesville, VA 22902, ph 1800 766 8009.

Curiosity about what exists beyond the known drew Bruce Moen into exploring the reality of human existence beyond death. His experience in helping 'retrieve' individuals killed during the Oklahoma City explosion gave him the impetus to write this book. His account of that event makes up the mind-blowing first chapter of *Voyages into the Unknown*.

For years Moen had been conducting his own investigations into extraordinary human experience. He'd been enthralled by Castaneda's altered realities; but it wasn't until he came across Robert Monroe's books and learned specific consciousness-expanding techniques like "Gateway Voyage" at The Monroe Institute that he was able to develop and refine his technique.

Applying the "Lifeline" technique, Moen undertook journeys of "Service Here" and "Service There" to help people prepare for the afterlife, as well as to assist recently deceased individuals find their way to "Focus 27"—an imagine-it-as-you-will

'clearing house' for souls finding their bearings and preparing for their next incarnation.

Voyages into the Unknown is a record not only of Bruce Moen's forays into the afterlife, but of his finding fragments of himself from past lives and regaining an appreciation of the totality of his consciousness, applicable in his present life.

And there's more to come after this first book in his "Exploring the Afterlife" series. Anyone who's curious about what's beyond our 'mundane' world will gain something from Moen's revelations and guidance.

GENETIC ENGINEERING: DREAM OR NIGHTMARE? The Brave New World of Bad Science and Big Business

by Mae-Wan Ho

Publisher: Gateway Books, UK, 1998

ISBN: 1-85860-051-0 (s/c) (304pp)

Price: AUD\$37.00; NZD\$44.95;

STG£11.00; NFLf39.90; USD\$15.95

Distributors: **Aust**—Banyan Tree Book Distributors, ph (08) 8363 4244; **Aust/NZ/UK/Eur**—NEXUS offices; **USA**—Access Publishers Network, ph 1800 345 0096.

Far from being able to end world hunger and eradicate disease, genetic engineering could ultimately destroy the human race and life as we know it on this planet, says UK-based biologist and activist Dr Mae-Wan Ho in her latest book, *Genetic Engineering: Dream or Nightmare?*.

The forecast "brave new world" is now a reality, she argues. Science and big business have formed an unprecedented "unholy alliance", where scientific integrity is compromised because of commercial imperatives, where the public good is pitted against commercial profit, where genetic biodiversity, food security and animal welfare are discarded, and where society's moral values and collective consciousness are corrupted by mis/disinformation.

While not wanting to blame individual geneticists for creating a monster, Dr Ho points out that much of what's done in biotechnology is bad science, where inadequate research is quickly applied without any thought of the inherent flaws in the technology or the inevitable hazards.

The fact that genes are "fluid" and can easily cross over to unrelated species by infection or be taken up in the environment is reason for an urgent moratorium to be called on all genetic engineering applications, Mae-Wan Ho stresses.

Dr Ho's holistic approach to biology rejects the reductionist, neo-Darwinist scientific worldview that is leading us to catastrophe. She warns that unless we become better informed and motivated, we'll never be able to deactivate the gene genie in time.





REVIEWS

BOOKS

THE SPACING OF PLANETS: The Solution to a 400-Year Mystery by Alexander Alan Scarborough

Publisher: Ander Publications, 1996
ISBN: 0-930258-03-7 (126pp l/f s/c)
Price: AUD\$20.00; USD\$19.95 + \$2.00 p&h in USA; Aust/NZ add USD\$5.00 p&h; elsewhere, add USD\$4.00

Distributor: **Aust**—Cameron Books, ph (02) 4758 7676; **USA**—Ander Publications, 202 View Pointe Lane, LaGrange, GA 30241-9103, ph (706) 884 3239.

Considering the human obsession with how we got here, any new thesis that expands our understanding is a welcome addition to the body of knowledge. Such is the case with Alexander Scarborough's thesis, *The Spacing of Planets*, on the origin and evolution of our solar system.

Scarborough presents a cogent argument for a fourth law of planetary motion, taking up where Kepler left off 400 years ago in trying to explain the geometric relationship between the orbits of the six planets known in his time. Using Kepler's three laws as well as Bode's law of geometric spacing, Scarborough reasons that the planets were originally spaced in accordance with the golden mean ratio of *phi*. Moreover, he has determined that any deviations from this spacing ratio are calculable using Kepler's third law related to planetary velocity.

He goes on to describe how planets evolve through five common stages. The smaller the sphere, the more rapid its evolution from nuclear energy mass (Sun), to gaseous (Jupiter, Saturn), to transitional (Uranus,

Neptune), to rocky (Earth, Venus, Mars), to inactive (Mercury, Pluto). These same evolutionary processes are also active within each planet, he says. The Earth's core is constantly engaged in "internal nucleosynthesis" which has created atmospheres, lands, oceans, life-forms and fuels. Indeed, he explains the development of hydrocarbon fuels (gas, oil, coal) as a function of these internal nuclear processes, not as the product of fossilised plant life.

Wherever *phi* is revealed, so too is a grand cosmic design—and Scarborough can even be forgiven for being so certain of the significance and scope of his thesis.

SUMMER WITH THE LEPRECHAUNS by Tanis Helliwell

Publisher: Blue Dolphin, USA, 1997
ISBN: 1-57733-001-3 (201pp s/c)
Price: AUD\$26.95; NZD\$33.95; NFLf28,90; USD\$13.00

Distributors: **Australia**—Specialist Publications, ph (02) 9736 2191; **NZ**—Peaceful Living, ph (07) 571 8105; **Eur**—NEXUS Office; **USA**—Blue Dolphin Publishing, ph (916) 265 6925.

Ten years ago Tanis Helliwell, a Canadian organisational consultant and teacher of inner mysteries, decided to spend the summer in a cottage in the west of Ireland, the land of her heritage, to find enlightenment. What happened was quite different from what she expected of her peaceful retreat, for soon after arriving at the cottage she was confronted by a leprechaun and his family that suddenly materialised in front of her.

The meeting was the first of many, for the leprechaun befriended Helliwell and shared insights about the elemental races (fairies, devas, pixies, elves, gnomes, leprechauns) that exist on this planet and are intrinsically involved in maintaining various subtle aspects of Nature's living systems.

This particular leprechaun claimed to have been studying humans for the last 100 years with a view to bridging the gap between the human and the elemental worlds. He said that both kingdoms are destined to become co-creators, assisting the evolution of each other as well as the healing of the planet. "If humans could see lighter vibrations and the life-force in all living things," the leprechaun said, "they wouldn't be harming the world the way they have been."

Whether *Summer with the Leprechauns*, Helliwell's record of her experiences, is read as a 'true' story or not, its messages have profound implications for the future of humanity and all living things. But apart from all the insights, this is also an enjoyable tale full of humour and local Irish colour that's hard to put down.

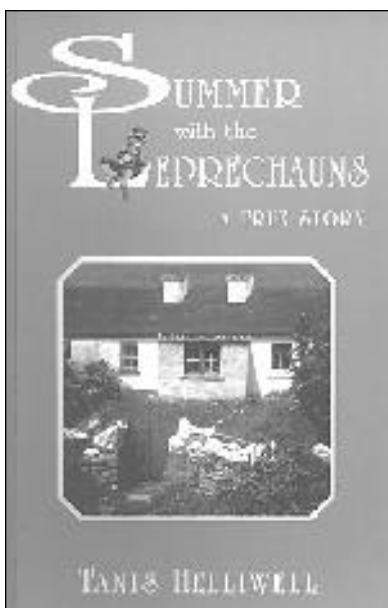

REVIEWS



BOOKS

ANCIENT MICRONESIA & THE LOST CITY OF NAN MADOL

by David Hatcher Childress

Publisher: Adventures Unlimited, 1998

ISBN: 0-932813-49-6 (200pp s/c)

Price: AUD\$28.00; NZD\$34.90;

STG£14.50; NFLf37.90; USD\$16.95 +p/h

Distributors: **Aust/NZ/UK/Eur**— NEXUS offices; **USA**—Adventures Unlimited, PO Box 74, Kempton, IL 60946, ph (815) 253 6390, fax (815) 253 6300.

The islands of Micronesia, situated in the western Pacific Ocean, are studded with ancient megalithic ruins, some built on a massive scale. But as author/adventurer David Hatcher Childress writes, the origin of these structures is uncertain.

In *Ancient Micronesia*, the latest in his "Lost Cities of the Pacific" series, Childress draws on his own travels to the region as well as evidence garnered by European explorers, archaeologists and anthropologists in the last few centuries.

On the island of Pohnpei, Childress visits the most imposing megalithic structure of all: the lost city of Nan Madol, whose central area comprises up to 100 artificial islets built with magnetic, crystalline basalt logs, each weighing up to 20 tons. Some of the structures contain 50-ton blocks and have 30-foot-high walls. But how were they put into place? According to local legend, the basalt logs were magically levitated into position by the islanders' ancestors.

But who were these ancient engineers and from where did they come? Some archaeologists date the ruins at up to 2,000 years old,

but it's been suggested that the structures were built by a megalithic culture that existed throughout the Pacific, well before the migrations of the islander races.

Childress's quest also takes in the menhirs of Palau, the Latte Stones of Guam, the canal city of Insaru on Kosrae, the large stone money discs on Yap and the roads on Malden Island. His glimpses into Micronesian culture, language, writing and myths are richly supported with maps, illustrations, archival b&w and recent colour photos.

PERPETUAL MOTION: An Ancient Mystery Solved? An Investigation into the Legend of Bessler's Wheel

by John Collins

Publisher: Permo Publications, UK, 1997

ISBN: 0-9531615-0-1 (240pp s/c)

Price: AUD\$40.00; STG£11.95;

USD\$21.99; CAN\$29.99

Distrib: **Aust**—Cameron Books, ph (02)

4758 7676, fax (02) 4758 9047; **UK**—

Counter Culture, ph/fax 01823 698895;

USA—New Leaf, ph (770) 948 7845.

The idea of perpetual motion is ancient, but debate heated up in the 18th century when the gulf widened between the orthodox, who considered perpetual motion impossible, and the inventors, who believed it achievable. That gulf persists to this day.

But whether or not perpetual motion was or is achievable depends to a large extent on its definition, according to author John Collins who has spent many years researching the life and work of the German inventor Johann Bessler (1680?–1745), better known by his coded name, "Orffyreus".

In 1712 Orffyreus demonstrated his first *perpetuum mobile* machine, a device consisting of a spoked wheel with horizontal axle, supported by two vertical beams, but he enclosed it so no one could see the internal workings. It appears, though, that few people were ever given that privilege, so exactly how it worked to achieve 26 rpm, lift loads and run for eight weeks at a time requires some reading between the lines.

After exhaustive translation and analysis of whatever documents, letters and newspaper accounts were available, Collins concludes in his book that Orffyreus was not a fraud—as his detractors had suggested for decades. It was just that by using metal weights within the structure he was also utilising gravity; therefore, by strict definition, his machine did not display true perpetual motion. Still, Collins believes that Bessler's Wheel is ready to be rediscovered, and he gives many suggestions as to how it could be built. Whoever can utilise this design will be well on the way to solving the problem of low-cost energy extraction.

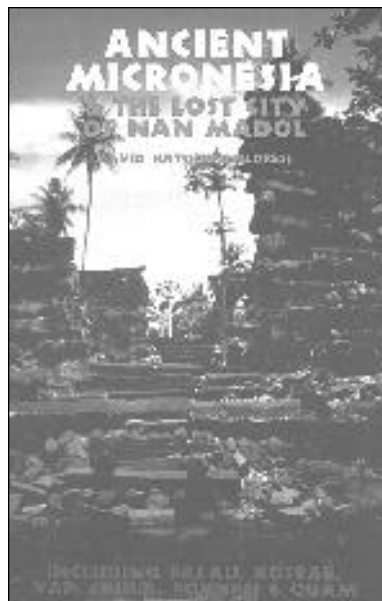



REVIEWS

THE MAGIC SQUARE OF THREE CRYSTAL THE OSCILLATIONS OF THE MAGIC SQUARE FOUR Part 1 & Part 2

by Arto Juhani Heino

Publisher: Ion Art, Australia, 1997
ISBN: 1-876406-00-3 (82pp); 1-876406-02-X (82pp); 1-876406-01-1 (72pp)
Price: AUD\$35.00 each (colour); AUD\$18.00 ea. (b&w) + p&h \$3.50 (each) or \$10.00 (set) in Aust; foreign p&h add AUD\$12.00 (each) or AUD\$25.00 (set)
Distributor: **Australia**—Ion Art, 84 Hemphill Avenue, Mount Pritchard, NSW 2170, ph/fax (02) 9823 5849; Sydney Esoteric Bookshop, ph (02) 9212 2225.

In this series of three manuscripts, author Arto Heino identifies a new "*phi* class" of engineering that combines art, mathematics, science and music, and draws on the work of Kepler, Tesla, Cathie, Searl and others.

Heino demonstrates a system that mimics Nature in the graphic form of magic squares that contain a *phi* ratio geometry. Such forms, he says, have mechanisms which follow the least-action principle, defining new sets of ordering while allowing freedom in design engineering. (Preliminary knowledge of magic squares and sacred geometry is essential for understanding his thesis.)

To give some idea of the scope, the first manuscript, *The Magic Square of Three Crystal*, considers the *phi* ratio, the golden triangle, Fibonacci numbers, musical intervals, bifurcation growth models, resonant geometry, Tesla coils, the ether and more.

The other two manuscripts comprise *The Oscillations of the Magic Square of Four*. Part 1 considers induction, spin, angular momentum, elemental crystals as well as schematics for an Adams motor stator, a sec-

ond Tesla coil, a vortex drive, a magnetron and a Wimshurst electrostatic generator.

Part two expands on the square-of-four groups and includes star pentagonals and planetary ratios as well as schematics for a mercury delay line, a magnetic roller motor, DC and AC motors and more.

For all their beautiful simplicity, these are challenging concepts, and Heino's intuitive, often poetic approach can be difficult to follow. Yet serious free-energy and antigravity researchers should be aware of the benefits to be gained by applying resonant geometry and square harmonics to their innovations.

BOMBS, BLISS & BABA: The Spiritual Autobiography Behind the Hilton Bombing Frame-Up

by Paul Narada Alister

Publisher: Better World Books, 1997
ISBN: 0-646-34789-6 (253pp s/c)
Price: AUD\$22.00 + \$4.00 p&h; foreign airmail, add 50% to p&h charges
Distributor: **Australia**—Better World Books, PO Box 177, Maleny Qld 4552, ph (07) 5494 2887, fax (07) 5494 3559.

When Paul Narada Alister joined the Ananda Marga religious sect in the early 1970s, he was expecting to devote his life to spiritual practice and community service. He certainly never expected that within a few years, by mid-June 1978, he, along with two fellow Margiis, would be in jail for conspiracy to murder and for alleged links to the tragic yet infamous Hilton Hotel bombing in Sydney in February that year.

The case of Paul Alister, Ross Dunn and Tim Anderson became a *cause célèbre*, for it was obvious they'd been framed and "ver-balled". Sentenced to 16 years and an extra 16 years each for attempted murder, the trio was eventually pardoned and released in May 1985 after much public pressure and a judicial inquiry (though in October 1990 Anderson was convicted over the Hilton bombing and then pardoned in June 1991).

Alister has finally written his own story, *Bombs, Bliss and Baba*, and it concerns much more than the Hilton bombing frame-up. He calls it a "spiritual autobiography", for it is a life story that is ultimately uplifting. His time in prison forced him deeper into his spiritual quest, into devotion to God and his Indian guru, Baba. But instead of being bitter, he sees the whole experience as a blessing that has brought empowerment, happiness and wisdom—exemplified in his continuing dedication to service within the Ananda Marga framework.

It would be ironic if the boys at ASIO and NSW Police Special Branch read Alister's book and gained some positive, spiritual insights. Perhaps they may yet reveal the whole truth about the Hilton bombing.

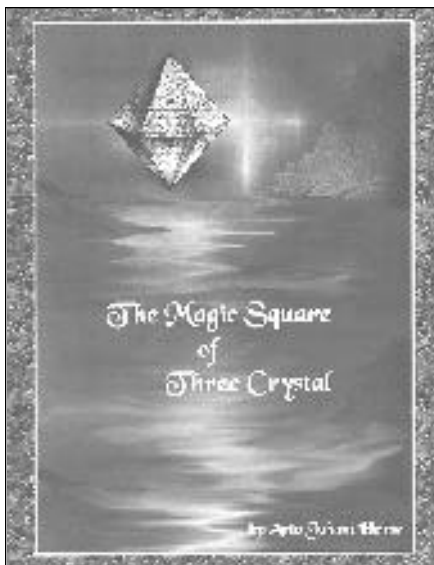

REVIEWS



BOOKS

BLACK HELICOPTERS II: THE ENDGAME STRATEGY

by Jim Keith

Publisher: IllumiNet Press, USA, 1997
ISBN: 1-881532-14-3 (205pp s/c)
Price: AUD\$30.00; NZD\$32.90;
STG£12.50; NFLf35.90; USD\$14.95 +p/h
Distributors: **Aust**—Cameron Books, ph
(02) 4758 7676; **NZ/UK/Eur**— NEXUS
offices; **USA**—Adventures Unlimited, PO
Box 74, Kempton, IL 60946, ph (815) 253
6390, fax (815) 253 6300.

Something is amiss when so many sightings of unmarked black helicopters throughout the US get nary a mention in the mainstream media. And if they do, it's likely they'll be dismissed as figments of deluded imaginations rather than be treated seriously, as investigator Jim Keith found out in his own dealings with NBC TV.

Since publication in 1994 of Keith's earlier book, *Black Helicopters over America* (see review in NEXUS 2/25), sightings reports have only increased. But black choppers aren't the only out-of-place military hardware turning up on American soil: reports continue to stream in about foreign troop movements, convoys of white, UN-marked armoured vehicles and Russian-built biochemical warfare tanks, coded road signs, and the establishment of large-scale detention centres. In this sequel, Keith provides a chronology of a sampling of these reports, and concludes that a New World Order "endgame" is being implemented.

Moreover, assaults on the citizenry are still being reported—not just counter-terrorism rehearsals and low-level buzzing, but black 'copters spraying townships and farms with toxic biological agents, and being seen at the site of cattle mutilations and in the company of UFOs. Local authorities will only admit



that they are not permitted to comment, and refer the inquisitive to the Dept of Defense.

Much of Keith's source material comes from the so-called patriot movement as well as confidential military contacts, and while he paints a bleak picture of an America that has been sold out, it's unclear in the end whether it's the NWO global elite or a Russian-Chinese Communist resurgence that he sees as the major threat to freedom.

PRODUCT

Reviewed by Duncan Roads

MINDLAB ORION

From Lifetools

Price: AUD\$495.00; STG£249.00; + del.
Distributors: **Aust**—Lifetools Australia, 5/1
Walton Crescent, Abbotsford, NSW 2046,
ph (02) 9712 0480; **UK**—Lifetools Ltd, 14-
16 Beswick St, Macclesfield SK11 8JF, ph
01625 502602, fax 0625 500979.

Now this is a fun device! It is not often I get the chance to 'road-test' brain-mind machines, so it is great to see how much they progress each time I do try one out. This one is the MindLab Orion and it comes in a box with a set of good headphones, a visor with built-in LEDs, a compact control device and a neat carrying-case. It's certainly good value for money. It comes with heaps of CDs and tapes as extras, many of them on language-learning, and there's plenty of instructional reading material to help you get the most of out the device.

The four user-modes of the Orion almost make it four machines in one:

Mode 1 – Audio Strobe: This is a patented technology which adds precisely synchronised patterns of light to music. Thus when you play Audio Strobe-encoded CDs, the coded signals will control the lights.

Mode 2 – Manual Mode: Use this mode to explore and discover which sound/light pulse rates produce the most interesting patterns, or, better still, to monitor their effects on your headspace. You can vary the sound/light pulse rates from left to right, as well as alternate the decimal points on the LEDs. Very versatile!

Mode 3 – ColourPulse: This transforms the beat of your favourite music CDs or tapes into patterns of pulsing light. It even works with spoken-word tapes and CDs.

Mode 4 – MicroPulse: In this setting, the built-in microphone picks up sounds around you and passes them through the ColourPulse circuitry, thus transforming external sounds into pulsing light.

Above all, this is a very compact device that can be used for entertainment, education (e.g., language learning), relaxation or invigoration, or for exploring states of awareness.



REVIEWS

AUDIO

Reviewed by Richard Giles

SIMPLE MAGIC

by Dee Rogers

Produced for Four Winds Music, Chatswood, Australia, 1997 (63mins)
Distributors: **Australia**—Four Winds Music, ph (02) 9486 3054; **Europe**—BSC Music, Germany, ph +49 08178 1246.

Another in the excellent series by Dee Rogers. On this album, *Simple Magic*, she has created an atmosphere with her smooth and simple keyboard style that transports the listener to a safe and tranquil environment. Imagine yourself strolling through fields of flowers surrounded by trees and rolling hills. Wonderful harmony for a quiet evening by the fire, for use in healing sessions and for general relaxation. There's indeed a simple magic in Dee's fingers.

ESSENCE

by Peter Kater

Produced for EarthSea Music, VA, USA, 1997 (75mins)
Distributor: **USA**—EarthSea Records, ph (540) 351 6191 or 1-888-48EARTH.

Peter Kater has an enviable record in the music industry, having produced dozens of albums in jazz, new age and ambient fields. In 1997 he established his own company, EarthSea Records to promote "extraordinary contemporary and indigenous music from around the world".

Essence is the first album in his EarthSea Healing Series, and the music serves to awaken healing, emotional honesty and self-nurturing in the listener. It features the evocative voice of Chris White, with violin, cello, piano and flute. Kater's music is intense, intimate and luscious.

O'R MABINOGI: Legends of the Celts by Ceredwen

Produced for Real Music, Sausalito, CA, USA, 1997 (58mins)
Distributors: **Australia**—New World Productions, ph (07) 3367 0788; **USA**—Real Music, ph (415) 331 8275.

Interest in everything Celtic has taken a firm hold on our culture. This beautiful album from Ceredwen, named after the Celtic goddess of inspiration, takes the listener on a journey through the legends of the Celts, retelling the great stories (*Mabinogi*) of the gods, kings and queens, of love and mystery, of the fairy underworld and Annwn, the Otherworld.

Ceredwen (Renée Gray and Andrew Fryer) has produced an enchanting album full of the magic of the Celts.

DAKAR HEART

by Jimi Mbaye

Produced for Shanachie Entertainment, USA, 1997 (54mins)

Distributors: **Aust**—MRA Entertainment, ph (07) 3849 6020; **USA**—Shanachie Entertainment, ph (973) 579 7763.

Youssou Ndur's band, Super Etoile, has some wonderfully talented African musicians—among them, lead guitarist Jimi Mbaye who has collaborated with Ndur on numbers of albums and projects over the years. Now, Mbaye has struck out with a solo album, *Dakar Heart*, taking the unique and warmhearted style he's brought to the Senegalese sound that Ndur has spread globally and putting it into his own compositions. His sound is elegant, simple and imaginative, in the style of *l'Afrique profonde* that he and Ndur promote.

The HOLY SPIRIT & The HOLY GRAIL by Adrian Wagner

Produced by Adrian Wagner, UK, 1997
Price: AUD\$32.00, STG£12.95 (CD) (59mins)

Distributor: **UK**—The Media Suite, +44 01239 710594, fax 01239 711343, e-mail enquiries@mediaquest.co.uk.

Adrian Wagner (the great, great grandson of composer Richard Wagner) wrote the music for *The Holy Spirit and The Holy Grail* after years of research into the Grail tradition. Coincidentally, as soon as Wagner read Sir Laurence Gardner's 1996 book, *Bloodline of the Holy Grail*, he was contacted by Gardner and then sent him a copy of his album. As soon as Sir Laurence heard it, he knew this was the music for his book.

Wagner's album is a mystical, inspirational trip into the intriguing realms of the Grail mystery and captures the depth of humanity's search for meaning. And it just may help change your perspective on history, as Gardner's book has done for so many. (See article this issue and in NEXUS 5/02.)

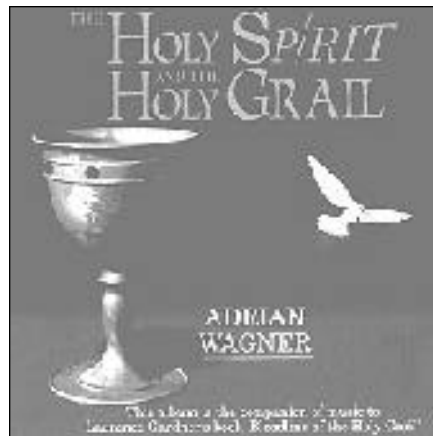

Continued from page 18

The published version does not mention this.

- The secret version says the fluoride may have acted similarly on the men's teeth, contributing to their toothlessness. The published version omits this statement and concludes that "the men were unusually healthy, judged from both a medical and dental point of view".

After comparing the secret and published versions of the censored study, toxicologist Phyllis Mullenix commented: "This makes me ashamed to be a scientist." Of other Cold War-era fluoride safety studies, she asked: "Were they all done like this?"

Asked for comment on the early links of the Manhattan Project to water fluoridation, Dr Harold Slavkin, Director of the National Institute for Dental Research—the US agency which today funds fluoride research—said: "I wasn't aware of any input from the Atomic Energy Commission." Nevertheless, he insisted that fluoride's efficacy and safety in the prevention of dental cavities over the last 50 years is well proved. "The motivation of a scientist is often different from the out-

come," he reflected. "I do not hold a prejudice about where the knowledge comes from."

Endnotes

1. Dale, Peter P., and McCauley, H. B, "Dental Conditions in Workers Chronically Exposed to Dilute and Anhydrous Hydrofluoric Acid", *Journal of the American Dental Association*, vol. 37, no. 2, August 1948, pp. 131-140. Note that Dale and McCauley were both Manhattan Project and, later, Program F personnel; they also authored the secret Manhattan Project paper.
2. Mullenix, Phyllis et al., "Neurotoxicity of Sodium Fluoride in Rats", *Neurotoxicology and Teratology*, vol. 17, no. 2, 1995, pp. 169-177.
3. Lamont, Lansing, *Day of Trinity*, Atheneum, New York City, 1965.
4. Chomsky, Noam, *The Cold War and the University*, New Press, New York City, 1997 (distributed by W.W. Norton & Co. Inc., NYC).
5. Hodge, H. C., "Fluoride metabolism: its significance in water fluoridation", in "Newburgh-Kingston caries-fluorine study: final report", *Journal of the American Dental Association*, vol. 52, March 1956.
6. Dale and McCauley, *ibid*.

About the Authors:

Joel Griffiths is a medical writer based in New York City. He is the author of a book on radiation hazards that included one of the first revelations of human radiation experiments, and has contributed numerous articles to med-

ical journals and popular publications.

Chris Bryson, who holds a Master's degree in journalism, is an independent reporter for BBC Radio, ABC-TV and public television in New York City, and writes for a variety of publications.

The authors wish to thank Clifford Honicker, Executive Director of the American Environmental Health Studies Project, Knoxville, TN, for his indispensable archival research.

Resources:

Copies of 155 pages of supporting documents, including all the declassified papers referred to in this article, can be obtained from the following contacts for a small fee to cover copying and postage:

- **Australia:** *Australian Fluoridation News*, GPO Box 935G, Melbourne, Victoria 3001, phone (03) 9592 5088, fax (03) 9592 4544.
- **New Zealand:** New Zealand Pure Water Association, 278 Dickson Road, Papamoa, Bay of Plenty, phone (07) 542 0499.
- **UK:** National Pure Water Association of the UK, 12 Dennington Lane, Crigglestone, Wakefield, WF4 3ET, phone 01924 254433, fax 01924 242380.
- **USA:** *Waste Not* newsletter, 82 Judson Street, Canton, NY 13617, phone (315) 379 9200, fax (315) 379 0448, e-mail wastenot@northnet.org.

Continued from page 34

Parliament which fears that the enlargement of the EU to Central and Eastern Europe—which will involve changes in legislation and future social and environmental policies at the EU level—are threatened by the MAI. These fears are mostly based on the most favoured nation and standstill clauses in the MAI.

The Parliament's draft resolution on the MAI ends by calling on "the parliaments and the governments of the member states not to sign the MAI until a thorough analysis, accessible to the public, has been carried out of the impact of this agreement on legislation within the EU". The European Commission, however, is under no obligation to fulfil this request. The European Parliament has demanded the right to ratify the agreement, but it remains unclear whether or not the Council of Ministers will heed this request.

THE INTERNATIONAL PUSH FOR INVESTMENT DEREGULATION

As has already been indicated throughout this briefing, the MAI is not the only ambitious attempt to deregulate investment

rules. Since 1995, governments all over the world have made some 600 changes in national investment legislation, 95 per cent of which have resulted in greater liberalisation. Over the past five years, the number of bilateral investment treaties has tripled to reach a current grand total of 1,330 agreements involving 162 countries.³⁹ The following is an overview of the multifaceted push for investment deregulation that has been launched by OECD countries.

Over and above the MAI, the EU, the United States and Japan dream of a global investment treaty within the WTO. Attempts to initiate negotiations on such a treaty—stimulated by the euphoria that followed the GATT signing—took place in 1995 and 1996.

Fierce Third World resistance to the so-called MIA (Multilateral Investment Agreement) resulted in a compromise: the creation of a WTO working group on investment—within which the struggle continues.

UNCTAD, another increasingly outspoken proponent of deregulation, plays a crucial role in moving Third World countries towards more neoliberal positions on investment, for instance by providing con-

sensus-building conferences.

And with its far less subtle approach, the IMF continues to use every opportunity to impose MAI-like rules on countries in financial crisis.

Activities on another front are likely to be stepped up in the coming months—a trans-Atlantic free trade zone, including full-scale investment deregulation, between the EU and the US. Preparations have been underway for several years between the US Government, the European Commission and corporate leaders in the Trans-Atlantic Business Dialogue (TABD). In early February, EU Commission Vice-President Brittan announced that the aim is to start negotiations at the EU-US Summit in May 1998—another path leading to the same goal, and with the same fundamental lack of public consultation let alone a public mandate.⁴⁰

MAI OR MIA: A TWO-TRACK INVESTMENT STRATEGY

The year 1995 was big for investment negotiations. Not only did MAI negotiations officially begin, but the OECD ministerial meeting in June of that year also agreed to push simultaneously for an MIA

within the WTO.⁴¹ Although there was general consensus on the desirability of a two-track strategy, the European Union was probably the strongest proponent of taking the fast-track approach with the WTO treaty.⁴² As European Commissioner Sir Leon Brittan put it: "I believe that developing countries have never been as receptive as they are today to the message that foreign direct investment is not a threat but a positive tool for economic growth... At a time when over half of new investment flows go to the developing world, this is a global issue that OECD countries cannot resolve alone... We must get the issue into WTO..."⁴³

The original idea was to launch negotiations on an MIA at the December 1996 WTO ministerial conference in Singapore. The proposal for an MIA outlined in a 1995 European Commission paper, "A Level Playing Field for Direct Investment Worldwide", closely resembled the MAI.⁴⁴ This MIA would grant foreign investors the rights of entry, establishment and national treatment in all sectors in all WTO member countries, would guarantee unrestricted capital and profit flows, and would require restructuring of tax and company laws.

What makes an investment treaty within the WTO attractive to Northern governments is that it would allow access to the WTO's dispute settlement mechanism—and especially to its cross-retaliation provisions which are a very powerful juridical instrument involving trade sanctions against non-compliant countries. Influential corporate lobby groups, in particular the European Round Table of Industrialists, have pressured for such a "GATT for investment" since the early 1990s.⁴⁵

To be continued next issue...

Endnotes

1. European Commission Press Release, "Commission Launches Discussion Paper on Worldwide Investment Rules", IP/95/52, 19 January 1995.
2. ICC report, "Multilateral Rules for Investment", 30 April 1996.
3. *Financial Times*, London, 2 February 1998.
4. OECD website, <http://www.oecd.org/>
5. Ibid.
6. Interview with Jan Huner, deputy of Mr Engering, head of the MAI negotiations, 28 January 1998. Huner did not mention Slovakia, which has previously often been mentioned as a candidate.
7. For an extensive overview of "glocalisation" and other new corporate market strategies, see the article, "Who Competes? Changing Landscapes of Corporate Control", by Nicholas Hildyard, Colin Hines and Tim Lang in *The Ecologist*, vol. 26, no. 4, July-August 1996.

8. Based on UNCTAD figures; see *Third World Resurgence*, no. 79, p. 18.
9. Testimony by Lori Wallach, public citizen, before the US Congress International Trade Commission, 15 May 1997.
10. UNCTAD, "World Investment Report 1997".
11. Dr P. Schuurman and Dr J. P. Huner, "International Investments", discussion paper for the Directorate General for Foreign Economic Relations, The Hague, February 1996.
12. Interview with Jan Huner, OECD, 28 January 1998.
13. William H. Witherell, Director for Financial, Fiscal and Enterprise Affairs at the OECD, in "The OECD Multilateral Agreement on Investment", *Transnational Corporations*, vol. 4, no. 2, August 1995, p. 8.
14. Idem. "These groups dealt, respectively, with liberalisation obligations under existing OECD instruments, liberalisation obligations in new areas, investment protection, dispute settlement and the involvement of non-members and institutional matters."
15. Witherell, *ibid.*, p. 12. The bulk of these consultations were with the members of the OECD's advisory group on investment, which includes the Central and Eastern European countries, and in "policy dialogue workshops" with South-East Asian and Latin American countries.
16. Under the 1975 Lome Convention, the 70 ACP countries were allowed duty-free exports into the EU as a form of aid. The Lome Convention is being renegotiated.
17. This was reported to have happened at, for instance, the meeting between EU and ACP countries in Kampala, Uganda, in October 1997. Roberto Bissio in *Third World Network Features*, 1680/97, p. 3.
18. The Dutch OECD negotiators wrote in their first report to the Dutch Parliament: "...the function of the treaty that will be agreed upon in the OECD framework is precisely to give the other WTO countries an idea of

MAI GALOMANIA! The Multilateral Agreement on Investment

Continued from page 87

what kind of elements a multilateral policy framework contains. The MAI therefore fulfils a catalysing role in the further development of policy consensus in this field." See Secretary of State for Economic Affairs Van Dok-van Weelen's first report on the MAI to the Dutch Parliament, "De onderhandelingen binnen de OESO inzake een Multilateraal Akkoord over investeringen", 2 November 1995.

19. Frans Engering, "The Multilateral Investment Agreement", in *Transnational Corporations*, vol. 5, no. 3, December 1996.

20. USCIB Investment Committee, USCIB website.

21. Cases would be facilitated by the International Chamber of Commerce's Court of Arbitration, the World Bank's International Center for the Settlement of Investment Disputes (ICSID) or the UNCITRAL rules (UNCITRAL is a UN agency which has developed rules for arbitration in international commercial disputes).

22. USCIB website.

23. Confidential official source.

24. ICC Commission on International Trade and Investment Policy, Document n.103/179 Rev., 30 April 1996.

25. Report to the Dutch Parliament by Secretary of State for Economic Affairs Van Dok-van Weelen, 2 November 1995, p. 4 (our translation) (see endnote 18).

26. Idem.

27. This is according to Dutch negotiator Marinus Sikkkel at a public hearing on the MAI in Utrecht, the Netherlands, 3 February 1998.

28. NGOs called for the suspension of negotiations to allow for public participation in the negotiations: "...an independent and comprehensive assessment of the social, environmental and development impact of the MAI with full public participation, the observation of

binding environment, labour, health, safety and human rights standards, the elimination of the investor state dispute settlement mechanism as well as the expropriation provision of the MAI and the renegotiation of the terms of withdrawal."

29. Chairman's Opening Remarks, 15 January 1998.

30. BIAAC consultation, 15 January 1998.

31. USCIB web page.

32. TUAC web page.

33. TUAC's concrete demands are the incorporation of the OECD Guidelines for Multinational Enterprises into the MAI, a structure to ensure the implementation of the guidelines, the commitment to enforce basic workers' rights, and the provision that foreign investment must not violate domestic or internationally recognised labour standards. See "The Multilateral Agreement on Investment: Key Issues for Trade Unions", TUAC Briefing Note for Affiliates, September 1997.

34. Interview with Roy Jones, TUAC Secretariat, 26 January 1998.

35. This shared responsibility is not clearly defined in any EU treaty, but is based on a decision by the European Court of Justice on the Uruguay Round of the GATT. MEPs have asked the Commission about this shared responsibility and have received vague responses.

36. Sir Leon Brittan in a speech on investment at a conference organised by the Royal Institute for International Affairs (Chatham House) and the London School of Economics, quoted in an EC press release, "Commission Calls on European Business to Intensify Worldwide Investment Efforts", IP/95/269, 17 March 1995.

37. Committee of External Economic Relations, "Draft Report on the Negotiations in the Framework of the OECD on a Multilateral Agreement on Investment (MAI)", 17 December 1997.

38. "Competition on rules" refers to steps that govern-

ments take to attract foreign investors, and may include relaxing environmental and social regulations, tax breaks, the establishment of free trade zones and so forth.

39. UNCTAD, "World Investment Report 1997".

40. *Financial Times*, London, 2 February 1998

41. This consensus was confirmed at several 1995 summits, including the Halifax G7 Summit in June and the Trans-Atlantic Summit between the EU and US in December.

42. EU Commissioner Sir Leon Brittan explained the two-track strategy as follows: "We must tell our non-OECD partners in the WTO what we are doing among ourselves, overcome their fears that an investment initiative goes against their interests, and prepare the ground for decisions in the inaugural WTO ministerial in the autumn of 1996. By then, the OECD will be nearing the end of a planned two-year negotiation: WTO will be well placed to consider a complementary negotiating mandate to free investment flows world-

wide." Source: see endnote 36.

43. Taken from a speech by Sir Leon Brittan at the Stockholm Trade Policy Seminar, 23 October 1995.

44. Martin Khor in *Third World Network Features*, 1409/96.

45. For instance, see "European Industry: A Partner for the Developing World. Foreign Direct Investment as a Tool for Economic Development and Cooperation: Suggestions for Future Improvement", ERT, 1993, p. 35.

About the Author:

Corporate Europe Observatory (CEO) is an Amsterdam-based non-profit organisation set up to monitor and report on the political activities of European corporations and their lobby groups.